

Synthesis of Filtering Structures for Microstrip Active Antennas Using Orlov's Formula

Fabio Urbani, Filiberto Bilotti, and Lucio Vegni

In this paper, a synthesis technique for nonuniform filtering structures to be employed in active integrated antenna layouts is presented. The idea is to suppress the higher harmonic contribution due to the presence of nonlinear components through a nonuniform transmission line properly designed via Orlov's synthesis formula. The theory presented is applied here to synthesize an amplifier-based active antenna layout for wireless local area network (WLAN) purposes working at 2.4 GHz. The numerical results presented show the capabilities of the proposed approach.

Keywords: Patch antennas, transmission lines, synthesis techniques.

I. Introduction

Active integrated antennas (AIAs) are components in which a passive antenna element and active circuitry are integrated on the same substrate [1]. The integration of both antennas and active circuits is responsible for greater compactness, lower costs, and higher power efficiency with respect to conventional passive layouts [2].

Specifically when active antennas also involve power amplifiers, most of the lost power is due to the amplifier output stage [3]. Therefore, there has been great interest during the last years in maximizing the power added efficiency, which is defined as the ratio between the power at the output port of the amplifier and the input power [3]. In order to achieve this goal, the higher-order harmonic contributions at the output port have to be reflected back to the device. Typical second harmonic tuning exploits a quarter-wavelength (where the wavelength is intended at the fundamental frequency) short-circuited stub connected at the output port, or chip-capacitors exhibiting a self-resonance at the second harmonic frequency.

In AIA layouts, however, the harmonic tuning is usually accomplished by using the inherent frequency response of the antenna element or by using a proper transmission line with a filtering behavior. The approach based on the antenna acting as a filter is very effective in enhancing the compactness of the layout, but leads to a very narrow-band frequency response. Therefore, such an approach cannot be effectively used in communication systems requiring multicarrier broadband CDMA operation.

In such cases, a more complicated layout involving a broadband filtering structure is more useful. For instance, in [4] Anzellotti and others have proposed the employment of a photonic band gap periodic transmission line in order to obtain a

Manuscript received Apr. 1, 2004; revised Jan. 26, 2005.

Fabio Urbani (phone: +1 956 574 6650, email : furbani@utb.edu) is with the Department of Engineering, University of Texas at Brownsville, USA.

Filiberto Bilotti (email: bilotti@uniroma3.it) and Lucio Vegni (email: vegni@uniroma3.it) are with the Department of Applied Electronics, University of Roma Tre, Rome, Italy.

proper broad-band tuning of the higher harmonic contributions in an AIA layout. The periodicity of the transmission line and the electric/geometric parameters of the periodic cell control the position along the frequency axis, the width and the depth of the stop-band. The incidence of each of these parameters on the stop-band characteristics has been derived and some useful design curves have been provided in [4].

Other filtering structures can be effectively used to achieve the same broad-band tuning behavior. In this paper, we focus our attention on nonuniform transmission lines because of their inherent broad-band behavior as matching and filtering structures [5], [6]. Although the analysis and synthesis of nonuniform transmission lines is an old and well established topic in electromagnetics and circuit theory, to the authors' best knowledge, the employment of such nonuniform structures in active antenna layouts has not yet been proposed in the open technical literature.

The aim of this paper therefore is to develop an efficient and effective design technique to synthesize the electrical and geometrical parameters of a nonuniform transmission line to be used in AIA layouts for higher harmonic tuning purposes.

The structure of the paper is as follows. In section II we describe the circuit equivalent network of the overall active antenna under analysis: the radiating element, the filtering nonuniform transmission line, and the amplifier. Section III presents the proposed design technique of the filtering nonuniform transmission line starting from Orlov's formula. Finally in section IV, some numerical results to show the capabilities and effectiveness of the design technique developed in the paper are reported.

II. Circuit Equivalent Network of an Active Integrated Antenna

The layout this paper refers to is depicted in Fig. 1. For simplicity, the antenna is considered as a transmitting device, but the same considerations can be also applied by reciprocity to the receiving operation mode.

The approximate equivalent circuit representing the passive radiating component can be obtained through the transmission line model described in [7]. Assuming that the form of the patch is the rectangular one depicted in Fig. 2, and that the patch is fed at one of its radiating edges by a microstrip line, the equivalent network representation for the patch is shown in Fig. 3.

The lumped elements in Fig. 3 take into account the radiation (conductance G) and the reactive effects (susceptance B) at the patch edges.

Simple approximate formulas for such elements can be obtained in the case of very thin dielectric substrates ($d < \lambda_0/10$),

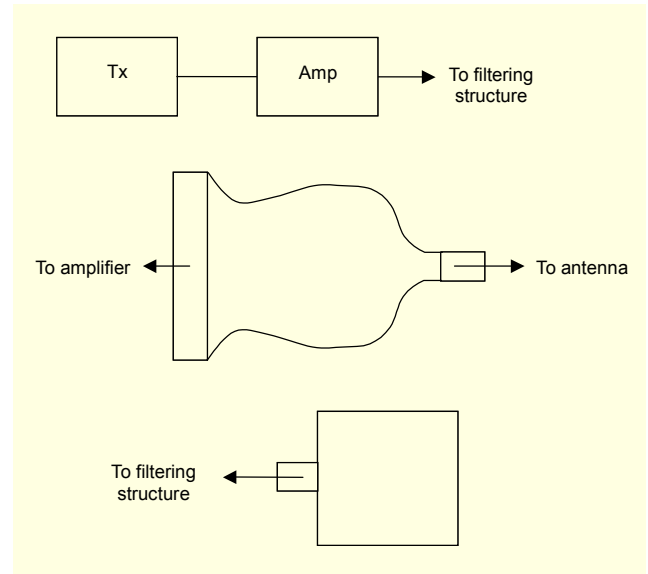

Fig. 1. Schematic layout of the active antenna.

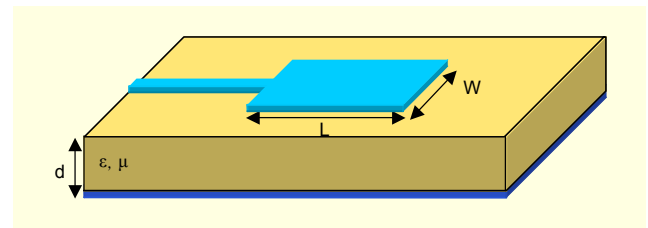

Fig. 2. Basic geometry of the rectangular patch antenna fed by a microstrip line at a radiating edge.

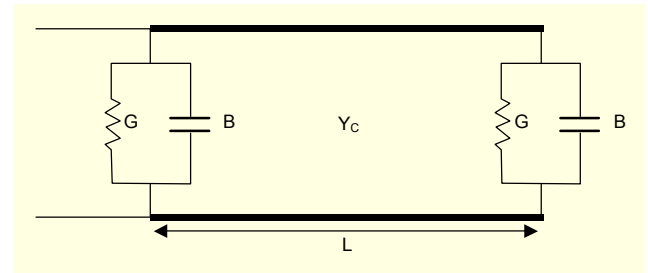

Fig. 3. Equivalent network representation of the rectangular patch depicted in Fig. 2.

and their expressions are given in [7] as

$$G = \frac{W}{120\lambda_0} \left[1 - \frac{1}{24} (k_0 d)^2 \right]$$

$$B = \frac{W}{120\lambda_0} \left[1 - 0.636 \ln(k_0 d) \right]$$
(1)

where λ_0 and $k_0 = 2\pi/\lambda_0$ are the wavelength and the wave number of the vacuum, respectively.

The characteristic impedance and the propagation constant

of the transmission line depicted in Fig. 3 are expressed in terms of the microstrip line parameters as

$$Z_c = \frac{120 \pi}{\sqrt{\epsilon_{r,\text{eff}}} \left[\frac{W}{d} + 1.393 + 0.667 \ln \left(\frac{W}{d} + 1.444 \right) \right]}, \quad (2)$$

$$\beta = \omega \sqrt{\epsilon_0 \mu_0} \sqrt{\epsilon_{r,\text{eff}}},$$

where the effective dielectric constant $\epsilon_{r,\text{eff}}$ is given by

$$\epsilon_{r,\text{eff}} = \frac{\epsilon_r + 1}{2} + \frac{\epsilon_r - 1}{2} \left(1 + 12 \frac{d}{W} \right)^{-1/2}, \quad (3)$$

and $W/d \geq 1$.

Using (1) through (3) and the equivalent network representation given in Fig. 3, it is possible to calculate in closed form the input impedance Z_{IN} of the radiating element as a function of frequency.

Since the output stage of the amplifier is characterized by low output impedance, a matching network between the antenna and the amplifier is required. Such a network can be designed using a nonuniform transmission line (NUTL) as sketched in Fig. 4. The design should also take into account that the NUTL has to behave not only as a matching structure, but also as a filtering structure in order to suppress the undesired high harmonic contributions coming from the amplifier.

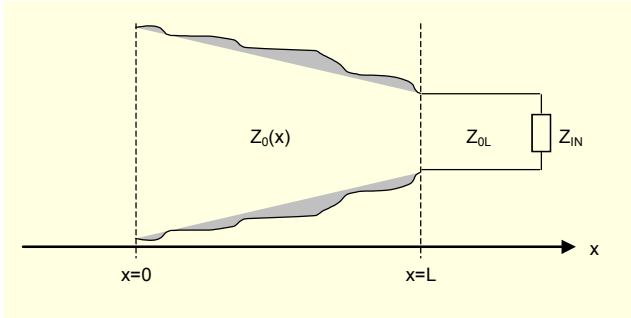

Fig. 4. Equivalent network representation of the matching/filtering structure consisting of an NUTL.

III. Design of the NUTL Filtering Structure

In this section, we propose an approach based on Orlov's formula [8] to design the NUTL acting as both a filtering and matching structure between the antenna and the amplifier output stage.

The goal therefore is to develop an effective design technique in order to derive the proper impedance profile, $Z_0(x)$ of the nonuniform structure depicted in Fig. 4, capable of both reflecting back the higher harmonics coming from the

amplifier and conveying the signal at the resonance frequency to the patch. In order to conduct such a design, we can use Orlov's synthesis formula in [8]:

$$p(x) = \frac{1}{\pi} \int_{-\infty}^{+\infty} \frac{\Gamma(k)[1 - |\Gamma_0(k)|^2] - \Gamma_0(k)[1 - |\Gamma(k)|^2]}{1 - |\Gamma(k)|^2 |\Gamma_0(k)|^2} e^{+2jkx} dk, \quad (4)$$

where k is the spatial frequency associated to the spatial variable x , and $p(x)$ is directly related to the characteristic impedance of the NUTL as follows:

$$p(x) = \frac{1}{2} \frac{1}{Z_0(x)} \frac{dZ_0(x)}{dx}, \quad (5)$$

whereas $\Gamma_0(k)$ is the reflection coefficient on the load section reported as $x = 0$ and expressed by

$$\Gamma_0(k) = \frac{Z_{\text{IN}}(k) - Z_{0L}}{Z_{\text{IN}}(k) + Z_{0L}} e^{-2j k L}, \quad (6)$$

and $\Gamma(k)$ is the reflection coefficient of the NUTL referred to as $x = 0$ function of frequency and is given by

$$\Gamma(k) = \frac{1}{1 + jQ \left(\frac{c_0 k}{2\pi f_0} - \frac{2\pi f_0}{c_0 k} \right)^2}, \quad (7)$$

where f_0 is the central frequency, c_0 is the speed of light in the vacuum and Q is the filter quality factor. The latter formula ensures a stop-band filtering behavior, and its parameters f_0 and Q should be designed for reflecting back the higher harmonics coming from the amplifier and for allowing the propagation at the fundamental operating frequency of the patch.

Once the integral in (4) has been solved numerically, the characteristic impedance profile of the nonuniform transmission line placed in between the patch and the amplifier can be finally obtained, solving the first-order differential of (5) as

$$Z_0(x) = Z_{0L} e^{-2 \int_{x=L}^{x=L} p(x) dx} e^{2 \int_{x=0}^{x=L} p(x) dx}. \quad (8)$$

From (8) then, calculating the required profile for the width of the microstrip line conductor is a straightforward matter, using the common microstrip formulas reported in [7].

IV. Numerical Results

The theory presented in the previous sections is applied here to synthesize an amplifier-based active antenna layout for wireless local area network (WLAN) purposes.

The lower band operating frequency of the Wi-Fi standard for WLAN applications is $f_r = 2.4$ GHz. In order to match this requirement, the rectangular microstrip patch antenna has been designed with the following electrical and geometrical parameters: $d = 1$ mm, $\epsilon_r = 2.33$ (RT-duroid) for the substrate, and $W = 5$ cm and $L = 3.9$ cm for the patch.

With this ensemble of values it is possible to evaluate the remaining quantities necessary for the synthesis using (1) through (3): $\epsilon_{r,\text{eff}} = 2.19$, $Z_c = 10.87 \Omega$, and $\beta = 31f_r \text{ m}^{-1}$. The corresponding input impedance of the rectangular patch is depicted in Fig. 5(a). Please note the higher order modes sustained by the patch geometry. Assuming that the characteristic impedance of the NUTL at the feed section ($x = L$) is $Z_{0L} = 100 \Omega$, the corresponding amplitude of the reflection coefficient at the patch input port is depicted in Fig. 5(b).

The NUTL microstrip filter is integrated on the same substrate of the antenna and should suppress the higher order harmonics coming from the amplifier at 4.8 and 7.2 GHz, respectively, which are very close to the resonance frequencies of the higher order modes of the patch.

Using (7) and assuming quality factor $Q = 1.2$ and central frequency $f_0 = 6$ GHz, the reflection coefficient amplitude of the NUTL filter to be designed is shown in Fig. 6. It is worthwhile to point out that the filter parameters Q and f_0 have been chosen in order to have a stop-band big enough to include both the second and third harmonics.

The numerical evaluation of the integral in (4) has been performed exploiting the periodicity of the integrand for high k values and the related symmetry properties. Once the function $p(x)$ is known numerically, the line impedance profile can be straightforwardly obtained from (8).

The impedance profile and the effectiveness of the filtering/matching structure designed depend also on the length of the NUTL. This length represents a degree of freedom in the present design and can be chosen to fulfill practical requirements (i.e., space occupancy of the device, etc.) In the following, we present the results for two different choices of the NUTL length. Particularly in Figs. 7(a) and 7(b), the characteristic impedance profiles of the NUTL are shown for the line lengths $L = 1$ cm and $L = 2$ cm, respectively, while the output impedance of the amplifier is $Z_{\text{out}} = 50 \Omega$.

The nonuniform microstrip width can be easily computed from the profiles in Fig. 7 by inversion of the common formulas used to calculate the characteristic impedance of the microstrip transmission line [7]. Please note that at $x = 0$ and at $x = L$, the matching requirements are satisfied (50Ω at $x = 0$ and 100Ω at $x = L$).

As a countercheck, the reflection coefficient behavior of the NUTL filters now designed can be determined from the following analysis formula (9) given in [8]:

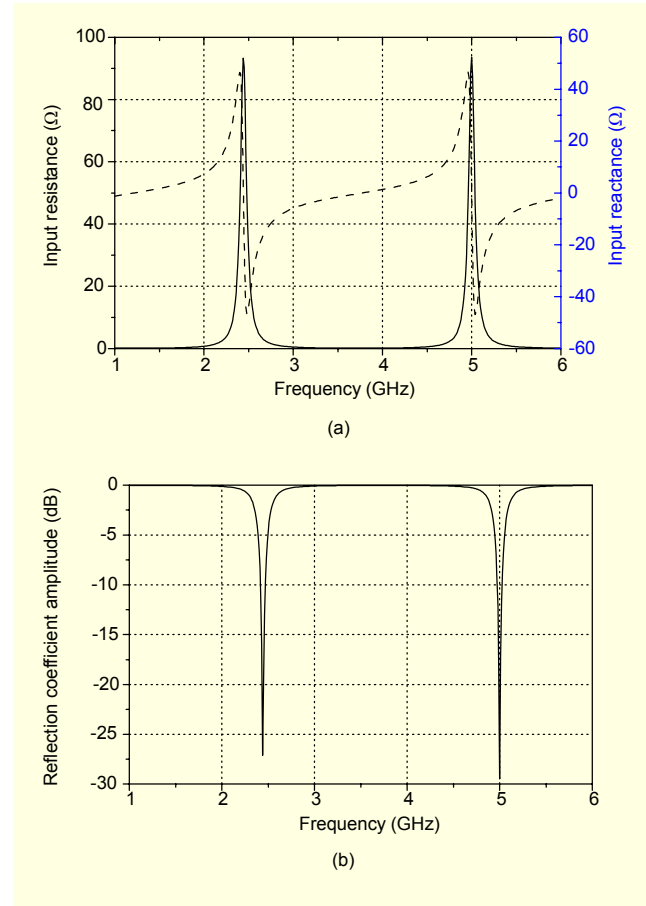

Fig. 5. (a) Input impedance and (b) reflection coefficient of the rectangular patch having the first resonance at 2.4 GHz.

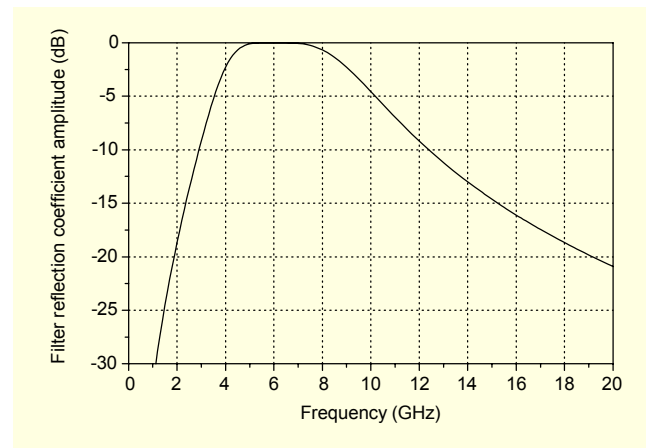

Fig. 6. Reflection coefficient amplitude of the NUTL filter to be designed.

$$\Gamma(k) = \frac{\Gamma_0(k) + \int_0^L e^{-2jkx} p(x) dx}{1 + \Gamma_0(k) + \int_0^L e^{+2jkx} p(x) dx}. \quad (9)$$

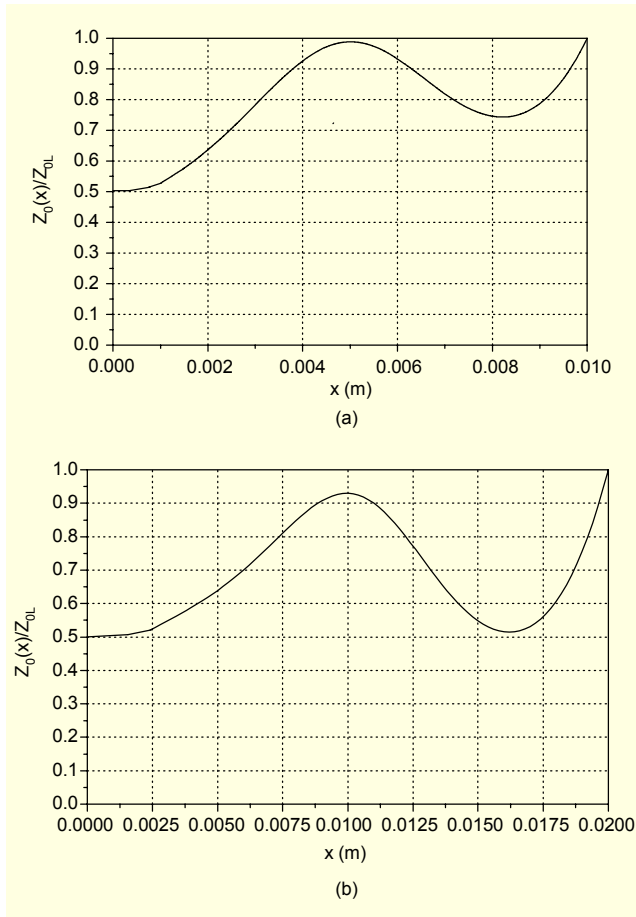

Fig. 7. Normalized characteristic impedance of the NUTL acting as a filter to cut off the higher harmonics coming from the amplifier: (a) $L=1$ cm and (b) $L=2$ cm.

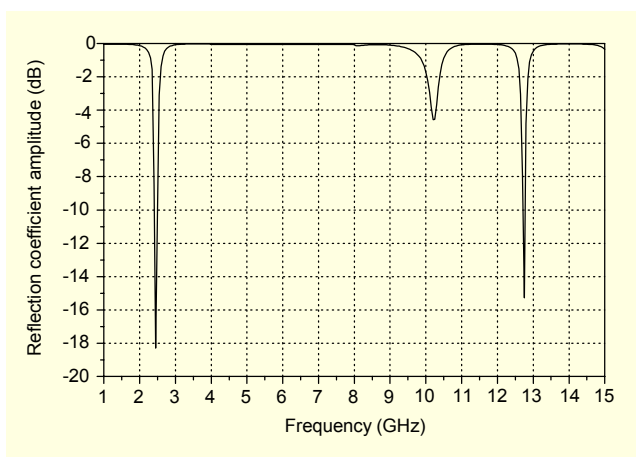

Fig. 8. Reflection coefficient at the input port of the NUTL filter considering the microstrip patch antenna as load.

Plugging in (9), the result obtained for $p(x)$ from the numerical integration in the previous design, and plotting the amplitude of the reflection coefficient as a function of frequency, we should find a good transmission around the

antenna working frequency (2.4 GHz) and a high rejection at both 4.8 GHz and 7.2 GHz (frequencies of the 2nd and 3rd harmonics coming from the amplifier).

This behavior is amply confirmed in Fig. 8 for the case $L = 2$ cm, where the frequency range of analysis has been extended up to 15 GHz to show that the patch modes with resonant frequencies higher than 8 GHz are not affected by the NUTL when the antenna operates as a receiving device.

V. Conclusions

In this paper, a synthesis technique for nonuniform filtering structures to be employed in active integrated antenna layouts has been presented. A higher-harmonic microstrip suppresser has been designed via Orlov's synthesis formula. In order to demonstrate the capability of the approach, it has been applied in the design of a nonuniform filtering/matching transmission line for a Wi-Fi active integrated antenna working at 2.4 GHz. The numerical results presented support the proposed theoretical approach.

References

- [1] J. Lin and T. Itoh, "Active Integrated Antennas," *IEEE Trans. Microwave Theory Tech.*, vol. MTT-42, no. 12, Dec. 1994, pp. 2186-2193.
- [2] Y. Qian and T. Itoh, "Progress in Active Integrated Antennas and Their Applications," *IEEE Trans. Microwave Theory Tech.*, vol. MTT-46, no. 11, Nov. 1998, pp. 1891-1900.
- [3] V. Radisic, Y. Qian, and T. Itoh, "Novel Architectures for High-Efficiency Amplifiers for Wireless Applications," *IEEE Trans. Microwave Theory Tech.*, vol. MTT-46, no. 11, Nov. 1998, pp. 1900-1909.
- [4] E. Anzellotti, F. Bilotti, and L. Vegni, "Broad-Band Tuning of an AIA Amplifier Using 1-D PBG Transmission Lines," *J. Electromag. Waves Applicat.*, vol. 17, no. 4, 2003, pp. 571-584.
- [5] L. Vegni, F. Urbani, and A. Toscano, "Exponentially Tapered Non Uniform Transmission Lines," *IEEE Trans. on Magnetics*, vol. 33, no. 2, Mar. 1997, pp.1492-1495.
- [6] A. Toscano, L. Vegni, and F. Urbani, "Exponentially Tapered Non Uniform Transmission Lines for the High-Pass Filter Design," *Microwave and Optical Technology Letters*, vol. 16, no. 4, Nov. 1997, pp. 227-229.
- [7] C.A. Balanis, *Antenna Theory: Analysis and Design*, John Wiley & Sons, Inc., 1982.
- [8] C.B. Sharpe, "An Alternative Derivation of Orlov's Synthesis Formula for Non-Uniform Lines," *Proc. IEE*, vol. 109, pt C, Mar. 1962, pp. 226-229.



Fabio Urbani was born in Rome, Italy. He received the Laurea degree and the PhD degree both in electronic engineering from the University of Rome La Sapienza, Rome, Italy, in 1994 and 1997, respectively. From 1998 to 2002, Dr. Urbani was a Senior Consultant for several international telecommunications firms.

Since 2002, he has been in the Department of Engineering of the University of Texas in Brownsville, USA, as an Assistant Professor of electronics. His research interest areas are in electromagnetic characterization of unconventional materials and structures, the design of microwave components for telecommunications, and computational techniques for electromagnetics under parallel computer architecture. He is also involved in research activity focused on educational methods in engineering. Dr. F. Urbani is a member of IEEE, and ASEE.



Filiberto Bilotti was born in Rome, Italy, on April 25, 1974. He received the Laurea degree (summa cum laude) and the PhD degree both in electronic engineering from the University of “Roma Tre,” Rome, Italy, in 1998 and 2002, respectively. From 2002 he has been with the Department of Applied Electronics of the same

university where he works as an Assistant Professor of electromagnetic field theory. His main research interests are in the analysis and synthesis of planar and conformal integrated components for telecommunication applications; in the development of improved numerical algorithms based on the method of moments, finite element method, and method of lines for an efficient analysis of printed antennas and circuits; and in the microwave and optical applications of complex media, metamaterials, and metasurfaces (including EBG, chiral, bi-anisotropic, left handed, artificial engineered materials and high-impedance, reactive, artificial magnetic surfaces). Dr. Bilotti is author of more than 150 papers in international journals and conference proceedings and serves as a reviewer of IEEE Transactions on Antennas and Propagations, IEEE Transactions on Microwave Theory and Techniques, Microwave and Optical Technology Letters, ETRI Journal, and Journal of Electromagnetic Waves and Applications. From 1999, he has been a national expert of the European actions COST260 and COST284 on antenna technology and design, and from 2003, he has been a reviewer on the European Community for scientific projects in the field of antennas and metamaterials. From 2004, Prof. Bilotti has been a member of the Governing Board and of the Executive Committee of the European Network of Excellence on Metamaterials. He has also been a member of the Steering Committee for the creation of the First European Doctoral School Programmes on Metamaterials.



Lucio Vegni was born in Castiglion Fiorentino, Italy, on June 20, 1943 and received the degree in electronic engineering from the University of Rome, Italy. After a period of work at Standard Elektrik Lorenz in Stuttgart (Germany), as an Antenna Designer, he joined Istituto di Elettronica of the University of Rome, where he

was a researcher in Applied Electronics. From 1976 up to 1980, he was a Research Professor of applied electronics at the University of L’Aquila. From 1980 up to 1985, he became a Research Professor of applied electronics and from 1985 up to 1992, he was an Associate Professor of electromagnetic compatibility at the University of Rome “La Sapienza.” Since 1992, he has been at the University of “Roma Tre,” Rome, Italy, where he is currently a Full Professor of electromagnetic field theory. His research interests are in the areas of microwave and millimeter wave circuits and antennas, with particular emphasis on the EMC problems. Specifically, he was active in the studies of partial coherence radio links, with particular attention on multipath electromagnetic propagation effects up to 1977. Then, he moved to the area of integrated microwave circuits, where he studied the electromagnetic modeling of the microstrip planar circuit and antenna. In co-operation with the industry, he was engaged in the development of integrated microstrip antennas for satellite applications and in the study of radiating system electromagnetic compatibility problems from 1985 up to 1990. From 1990 up to now, he has been actively working on theoretical and numerical aspects of new planar antenna modeling involving unconventional materials. In these recent studies, he has offered new contributions to equivalent circuit representations of planar microwave components and new variational formulations for their numerical simulations. Finally, in the area of unconventional materials, he gave noteworthy contributions to the study of chiral and omega grounded dielectric slab antennas. All his contributions have appeared in more than 250 international papers (journals and transactions) and conferences. Prof. L. Vegni is a member of the European Chiral Group and Italian Electrical and Electronic Society (AEI).