

## Magnetic Abrasive Polishing for Internal Face of STS Tube using Sludge Abrasive Grain

Hee-Nam Kim<sup>a</sup>

*Department of Mechanical Engineering, Myongji University,  
Nam-dong, Yongin-si, Gyeonggi-do 449-728, Korea*

Dea-Wha Soh and Sang-Jeen Hong

*Department of Electronic Engineering, Myongji University,  
Nam-dong, Yongin-si, Gyeonggi-do 449-728, Korea*

Byung-Woo Lee

*Precision Measurement Team, Korea Testing Laboratory,  
222-13 Kuro-dong, Kuro-gu, Seoul 152-848, Korea*

<sup>a</sup>E-mail : [hnkim@mju.ac.kr](mailto:hnkim@mju.ac.kr)

(Received June 8 2005, Accepted June 15 2005)

In this paper, we have investigated the characteristics of the magnetic abrasive using sludge on polishing of internal finishing of seamless stainless steel (STS304) tube applying magnetic abrasive polishing. Either white alumina (WA) or green carborundum (GC) grain was used to resin sludge at a low temperature, and the sludge of magnetic abrasive powder was synthesized and crushed into 200 meshes. Surface roughness was measured before and after polishing, and more than 40 % of improvement of surface roughness was achieved when WA grain was used under a specific condition. Even though some degree of surface roughness due to deeper scratches still exist, but the result showed a prospective magnetic abrasive polishing using sludge with WA or GC grains.

*Keywords* : Magnetic abrasive, Sludge, White alumina, Green carborundum, Roughness

### 1. INTRODUCTION

As the technology of industry is continuously developing, more precise and debris free parts are required in numerous manufacturing tools for food production, medical instrument, and semiconductor manufacturing. A processing method that relies on direct contact of tools to processing material has been widely used for most of applications, but this can create deformation and debris in a local area due to mechanical cutting.

Numerous efforts have been made to avoid potential problems and improve the preciseness and cleanness, and one of them is magnetic abrasive polishing method. Magnetic abrasive polishing utilizes magnetism that pulls a magnetic substance and enables to provide fine finishing. Many study for polishing tools and proper abrasive has been performed[1-10]: the polishing performance associated with magnitude of the magnetism and the placement of poles, developing abrasive for highly

solid ceramic and a ultra high alloy, synthesize abrasive using CBN, iron oxide, and alumina. Since abrasive in magnetic abrasive polishing determines the precision and cleanness, developing effective abrasive and polishing method is a key to success.

In this experiment, sludge from steel manufacturing was recycled as magnetic material. The sludge was processed with white alumina (WA) and green carborundum (GC) grain at a low temperature and applied for the polishing of internal finishing of seamless stainless steel tube applying magnetic abrasive polishing. Recycling of sludge from steel industry is beneficial in terms of manufacturing cost and environmentally advantageous. The ultimate goals of this study are;

- 1) increasing practical use of existing common lathe for fine polishing with a simple attachment of magnetic generator;
- 2) investigating proper process condition with minimum cost.

## 2. EXPERIMENTAL APPARATUS

### 2.1 Magnetic abrasion

A high gradient electromagnet whose maximum flux is 1.5 Tesla was employed, and the experiment was performed attaching to an existing common lathe. Figure 1 and 2 illustrates a schematic of the magnetic abrasive experimental set up.

In order to easily control the air gap between poles and entity; poles were designed to be perpendicular to the sample for rectilinear motion.

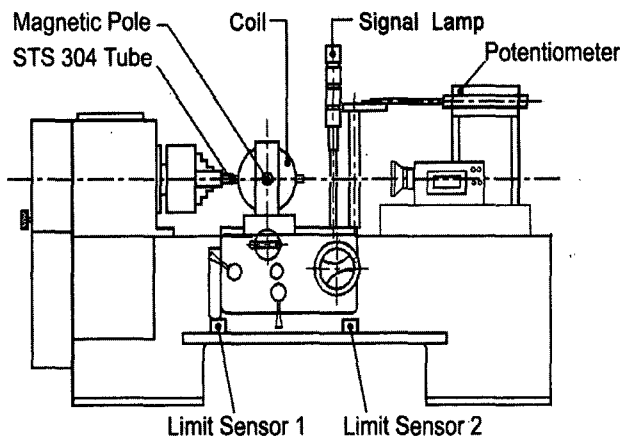

Fig. 1. A schematic of experimental set up.

### 2.2 Magnetic abrasive and sample

Sludge and 1,000 meshes of WA and GC grains were used for magnetic material and abrasive, respectively. Each type of magnetic abrasive was synthesized to be approximately 30 meshes in granular structure. The compositions of magnetic abrasives are provided in Table 1.

Sample material in this experiment is the stainless steel tube (STS304), which is extensively used for the pressure parts of automotive systems. The geometry of the sample is presented in Fig. 2.

Table 1. Compositions of the mixture rate.

Magnetic material	Sludge (Fe <sub>3</sub> O <sub>4</sub> )
Abrasive grain	WA and GC
Composition	1 : 1
Resin	0.20 (ml/g)
Synthesis temperature	185 (°C)
Synthesis time	120 (minutes)
Average particle size	30 (meshes)

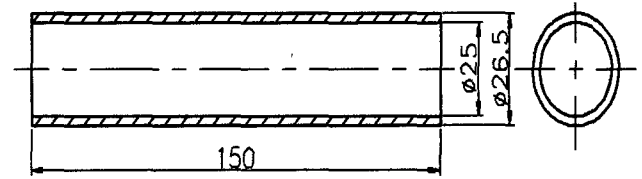

Fig. 2. Geometry and dimension of specimen.

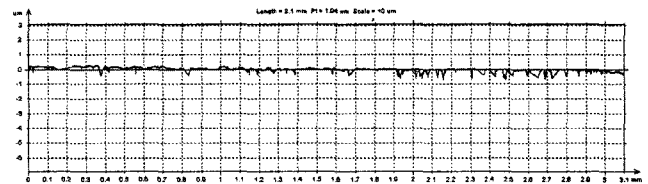

Fig. 3. A surface roughness curve of internal face in STS304 tube.

Surface roughness of samples was also measured before any polishing, and their averaged values are ranges from 0.08 to 0.09 μmRa. An example of measured surface roughness is provided in Fig. 3.

### 2.3 Experimental method

As it is depicted in Fig. 2, seamless stainless steel tube was loaded on the magnetic abrasive polishing tool with 2mm of air gap between the outer surface of the tubes and poles. Then, a series of experiments was performed according to the polishing conditions provided in Table 2.

Table 2. Polishing conditions.

Work piece	Stainless steel (STS304)
Polishing speed	31.8, 54.9, and 63.6 (m/min)
Feed rate	0.15 (mm/rev)
Magnetic flux density	1,500, 3,000, and 6,000 (G)
Pass number	5 and 10 (times)
Grain type	Granular structure

## 3. RESULTS AND DISCUSSION

The inter-surface roughness of the tubes polished with WA or GC grains of 30 meshes' granular structure is presented in Fig. 4(a) and (b). As in the case of WA in Fig. 4(a), the finest surface was achieved with the following condition; magnetic flux density=1500G, polishing velocity=63.6 m/min, and five times repetitions of polishing.

The surface roughness increased along the increment of

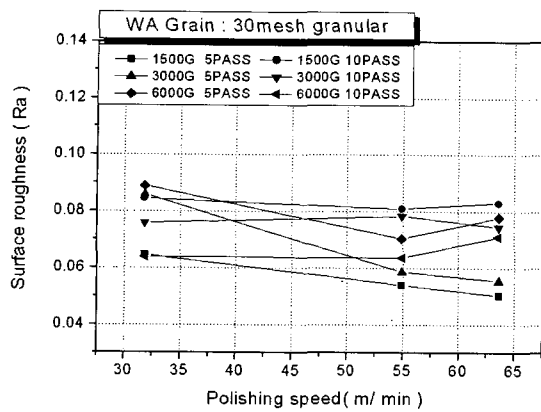

(a) granular structure type magnetic abrasive: WA

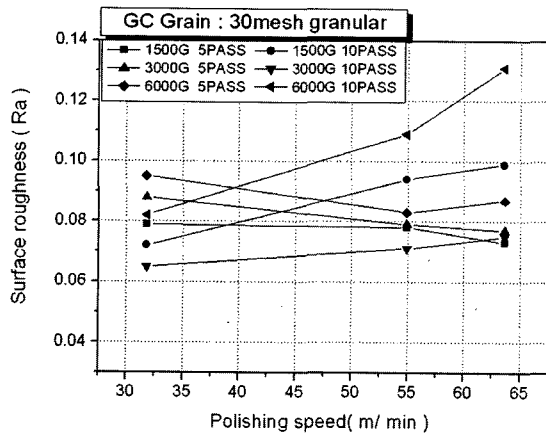

(b) granular structure type magnetic abrasive: GC

Fig. 4. Surface roughness according to polishing condition.

magnetic flux density to 3000G and 6000G, and this implies that magnetic flux density does not always proportional to the degree of roughness. In other words, even with small amount of magnetic flux density, finer surface can be achieved when the polishing velocity is controlled within some degree such ring movement does not take place. When the polishing is repeated over 10 times at the velocity of 31.8 m/min, minimum degree of roughness was obtained at 6000G and the roughness increased in the order to 3000G and 1500G. This phenomenon is speculated that self agitation of strong magnetic brush occurred at 6000G has effect on replacing existing abrasive grains with fresh ones and contributes to achieving mature polishing.

Figure 4(b) also shows the surface roughness vs. polishing speed over various conditions with GC grains. Generally speaking, WA grains have a tendency of outperforming than GC grains in terms of surface roughness. This can be explain that GC grains has better

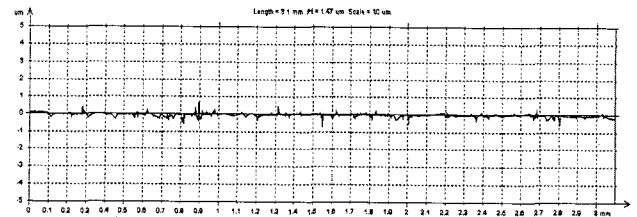
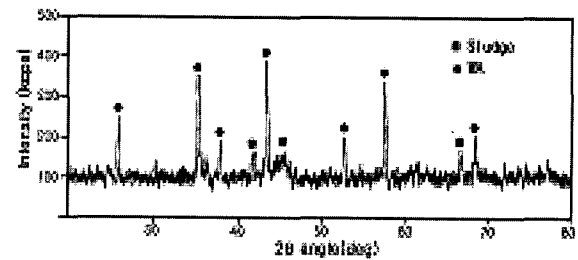
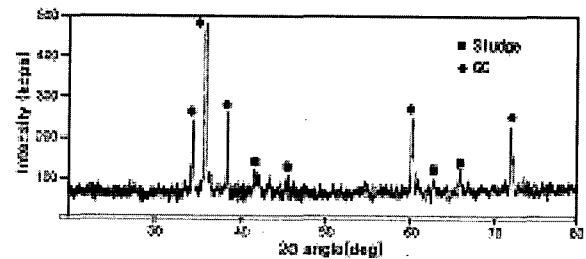

Fig. 5. Surface roughness profile after magnetic polishing(WA, 63.6 m/min, 1500G, 5 Pass).



(a) Sludge + WA



(b) Sludge + GC

Fig. 6. XRD analysis pattern of magnetic abrasive.

hardness than WA, so sharp cut by GC may creates relatively deeper scratches inside the tube. At the polishing velocity of 31.8 m/min over five times of repetitions, surface roughness increases with the rise of magnetic flux density in the order of 1500G, 3000G, and 6000G. Once again, this result is due to the sharpness and hardness of GC grains that creates strong magnetism. In addition, the surface roughness increased significantly along the polishing velocity at 10 times repetitions. This showed that polishing at higher magnetic flux density with harder grains can creates greater roughness. Therefore, magnetic abrasive contains GC grains can degrade the surface roughness at high polishing velocity (63.6 m/m in this exercise).

As it is illustrated in the figure, the when the polishing is repeated over 10 times, finest polishing was achieved at 54.9 m/mim with 3000G and 31.8 m/m with either 1500G or 6000G. Surface roughness profile after magnetic polishing with WA grains under the condition of 63.6 m/min, 1500G, and 5 pass is presented in Fig. 5. Comparing with the profile before any treatment, improved surface profile has been achieved. However,

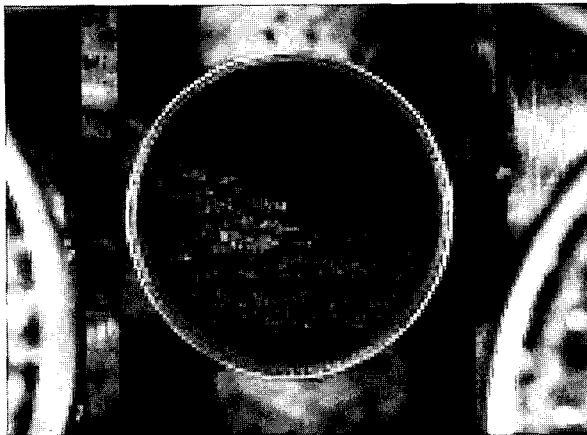

(a) standstill state



(b) rotation state

Fig. 7. Photographs of magnetic brush (magnetic flux density 6,000G).

some amounts of deeper scratches still exist, and they are responsible for the averaged roughness of  $0.0503 \mu\text{mRa}$ .

Figure 6 and Fig. 7 show the XRD analysis pattern of magnetic abrasives (WA and GC) and photographs of magnetic brush (magnetic flux density 6,000G) which were good magnetic abrasives and well-done magnetic polishing brush, respectably.

#### 4. CONCLUSION

According to the study of magnetic abrasive polishing using sludge from steel manufacturing applying to the seamless stainless steel tube, we have the following three conclusions:

- (1) WA abrasive can provide satisfying amount of surface roughness under the following process condition: magnetic flux density=1500G, polishing velocity=63.6 m/min. In addition, the polishing performance improves along the increment of magnetic flux density.
- (2) Sludge mixed with WA grains outperforms than GC grains under the same polishing condition, and this shows a good potential as an abrasive.
- (3) Magnetic abrasive polishing has been successfully performed with the synthesis of either WA or GC as abrasive and sludge as magnetic material.

#### REFERENCES

- [1] M. Anzai and T. Nakagawa, "Improve the efficient of magnetic finishing", *SEISAN KENKYU*, Vol. 45, No. 12, p. 816, 1993.
- [2] T. Shinmura and H. Yamaguchi, "Study on a new internal finishing process by applying magnetic abrasive machining", *J. JSME*, Vol. 59, No. 560, p. 293, 1993.
- [3] T. Shinmura, Y. Hamano, and H. Yamaguchi, "A new precisio deburring process for inside tubes by the application of magnetic abrasive maching", *J. JSME*, Vol. 64, No. 620, p. 312, 1998.
- [4] T. Shinmura and T. Aizawa, "Study on internal finishing of a non-ferromagnetic tubing by magnetic abrasive machining process", *Journal of JSPE*, Vol. 54, No. 4, p. 767, 1987.
- [5] M. Anzai, T. Sudo, and T. Nakagawa, "Development of magnetic abrasive and it's finishing characteristics", *SEISAN KENKYU*, Vol. 43, No. 11, p. 13 1991.
- [6] H. N. Kim, Y. K. Yun, and J. W. Shim, "Ultra finishing by magnet-abrasive grinding for internal-face of STS304 pipe", *Proc. Conf. KSPE*, p. 947, 2001.
- [7] H. N. Kim, Y. K. Yun, and J. W. Shim, "Super precise finishing of internal-face in STS304 pipe using the magnetic abrasive polishing", *J. of the Korea Institute of Industrial Safety*, Vol. 17, No. 3, p. 30, 2002.
- [8] H. N. Kim, S. K. Song, Y. J. Chung, Y. K. Yun, H. W. Kim, S. W. Cho, and J. W. Shim, "Development of the magnetic abrasive using Ba-Ferrite", *J. of the Korea Institute of Industrial Safety*, Vol. 18, No. 2, p. 46, 2003.

- [9] H. N. Kim, S. K. Song, Y. K. Yun, H. W. Kim, B. S. Kim, H. J. Ahn, and J. W. Shim, "The effects of Ba-ferrite magnetic abrasive behavior on polishing characteristics", Proc. of the Korean Society of Precision Engineering Conference, p. 565, 2003.
- [10] H. N. Kim, D. W. Soh, S. J. Hong, "Magnetic Abrasive Polishing for Internal Face of Stainless Steel Tube using Sludge Abrasive Grain", Proc. 2004 Autumn Conf. KIEEME, p. 77, 2004.