

각종 시설물 전원계통의 전압과 전류고조파 실태

(Actual Conditions of Voltage and Current Harmonics on Low-voltage Power Systems Supplying Various Facilities)

이복희* · 백영환

(Bok-Hee Lee · Young-Hwan Baek)

요 약

본 연구는 각종 부하에 전력을 공급하고 있는 저압 전원계통에 나타나는 전압과 전류고조파의 실태조사에 관한 것으로 22.9[kV]/380[V]/220[V] 수전용 변압기 2차측 모선에서 측정하고, 그 결과를 IEEE와 IEC의 고조파 제한규격과 비교하여 검토하였다. 본 연구 대상의 전원선의 전압 중합왜형률은 적정수준으로 5[%]이하이었다. 이에 반하여 전류왜형은 전압보다 매우 크게 나타났으며, 전류고조파는 전압고조파보다 훨씬 크게 나타났으며, 전류고조파 왜형율은 15.7~60.4[%]로 매우 넓은 범위에 분포되어 있다. 특히 개인용 컴퓨터와 형광조명을 주로 사용하는 사무용 건물의 전원선 전류왜곡은 공장의 부하전류의 왜곡에 비해 심하게 나타났다. 본 연구 조사 대상의 전원선 고조파 실태에서 전압고조파는 IEEE와 IEC규격의 제한값 이내이었지만 전류고조파는 이들 규격의 제한을 훨씬 초과하는 것으로 나타났다.

Abstract

This paper presents the actual conditions and reform measures of voltage and current harmonics being made in low-voltage power systems supplying various loads. The measurements were carried out at the secondary output terminals of 22.9[kV]/380[V]/220[V] customer's transformers, and the results were discussed on the basis of the comparison with IEEE and IEC harmonics control standards. The voltage THDs of the power systems employed in this survey were less than 5[%] that is considered to be acceptable. On the contrary, the current distortions were significantly greater than the voltage distortions, and the current THDs were distributed over the wide-range from 15.7 to 60.4[%]. In particular, the current distortion on the low voltage power lines of office buildings in which many PC and fluorescent lamps are used is remarkably more serious than that of factory facilities. As a result, the voltage distortion factors are observed within the range of its allowable level or less than the limits, but the current distortion factors are significantly greater than the limits of IEEE and IEC standards.

Key Words : Voltage harmonic, Current harmonics, Series reactor, THD, TDD, Harmonics compensation

* 주저자 : 인하대학교 전자전기공학부 교수, Tel : 032-860-7398, Fax : 032-863-5822, E-mail : bhlee@inha.ac.kr
접수일자 : 2005년 2월 21일, 1차심사 : 2005년 2월 22일, 2차심사 : 2005년 3월 16일, 심사완료 : 2005년 3월 24일

1. Introduction

Harmonics on the low-voltage supply system are becoming a vital problem due to the increasing use of fluorescent lighting and semiconductor equipments. Because most power electronics equipments are worked by rapid switching operations of voltages and currents, all power electronic converters produce electromagnetic interference and inject current harmonics into the utility system. Voltage and current harmonics are a source of electrical pollution in power systems. Widespread applications of power electronic-based devices lead to increasing attentions to disturbances on the ac supply mains.

With the increasing sensitivity and vulnerability of modern semiconductor integrated circuits in highly information-oriented environments, issues such as harmonics and disturbances on the mains are becoming more important. That is, the adverse effect of power quality is caused by increasing use of power electronics devices; distortion of voltage and current waveforms, harmonics, voltage and current imbalances, low power factor, and lighting flicker. In particular, computers are very vulnerable to malfunctions caused by disturbances in mains voltage. Understanding of the aspect and distribution of voltage and current harmonics on the mains is important for solving power quality problems. Thus, a variety of works and countermeasures against the effects of power line disturbances including harmonics on the sensitive electronic devices have been intensively carried out in domestic and foreign countries[1-5].

This work attempts to survey the actual conditions of voltage and current harmonics in the low-voltage ac power systems that contain nonlinear loads. In order to do this, distortion factors of the voltage and current waveforms and their harmonics spectrum on the low-voltage ac

power lines supplying electric power to the various loads for school, hospital, office building and factory were measured and discussed.

2. Measurement set-up and Methods

The harmonic measuring instrument comprises the analyzer, voltage probes, clamp-on current transformers with the frequency range up to 10 kHz, the accuracies of better than 3%, and coaxial cable and optical leads. The three-phase power quality analyzer used in this work can measure and calculate the voltage and current waveforms, all harmonic distortion factors, harmonic angles, and active, reactive and apparent power, power factor, short-term flicker for voltages, phase unbalance for voltage and current, and etc. The power quality analyzer can not only measure an instant image of a network's principal characteristics but also display its variation over a period of time. The sampling frequency of the power quality analyzer is 12.8[kHz] per channel at 50[Hz] and the error of total harmonic ratio in the reference conditions is less than 1[%].

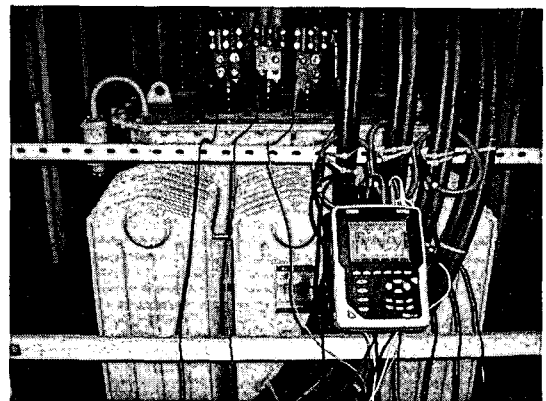

Fig. 1. Photograph showing the experimental set-up of the voltage and current measurements at the secondary bus of custom's transformer

각종 시설물 전원계통의 전압과 전류고조파 실태

The measurements of the voltage and current waveforms were carried out at the secondary output terminals of 22.9[kV]/380[V]/220[V] customer's transformers. Figure 1. shows a photograph of the experimental set-up including the measuring instrument in 3-phase 4-wires power system. The analyzer is connected directly to the bus conductors to take the accurate measurement of the voltage components. Individual distortion factors and total harmonic distortions(THDs) of the voltage and current produced by various types of non-linear loads are measured and calculated in on-site tests, and the experimental results are presented and discussed.

3. Results and Discussion

3.1 Voltage and current harmonics on the mains supplying various loads

(1) School

The voltage harmonics may be produced by a variety of sources. The sources include magnetic saturation of power system transformers as well as the harmonic currents injected by power electronic loads. Also, the harmonic currents flowing through the power system impedances cause harmonic voltages. The most common sources of harmonics on the ac power supply mains are power electronic loads such as switch-mode power supplies and electronic switches to chop waveforms or to convert ac to dc.

The electric facilities of regular school are mainly composed of personal computers, teaching aids, air-conditioners, and fluorescent lamps. The capacity of the receiving power transformer is a 400[kVA]. The measurements were carried out during school hours during 10:30-11:00AM on

October 12, 2003. At that time, the power lines supply a 187[kW] load. This measuring condition is a typical example of the normal operation state of school electric facilities. Figures 2. and 3. show examples of line-to-line voltage and line current waveforms and their harmonics spectrum on the 3-phase, 4-wire power lines supplying electric power to school facilities. The numbers ①, ②, ③ in Fig. 2. through Fig. 9. indicate the characteristic values of a, b, c-phases, respectively.

The most common distortion factor is the total harmonic distortion. THD applies to both voltage and current and is defined as the root mean square(rms) value of harmonics divided by the rms value of the fundamental[2].

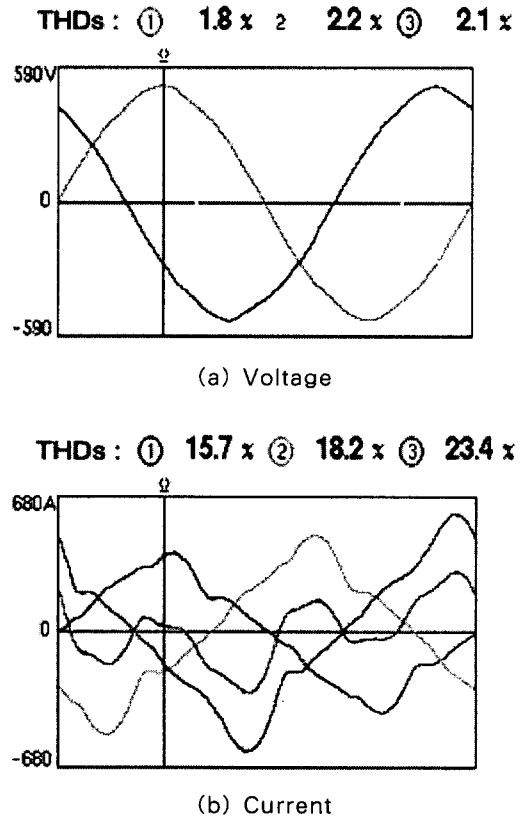

Fig. 2. Typical waveforms of the voltage and current on the power lines supplying school facility

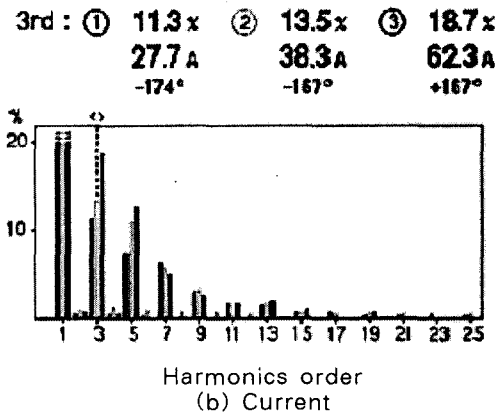
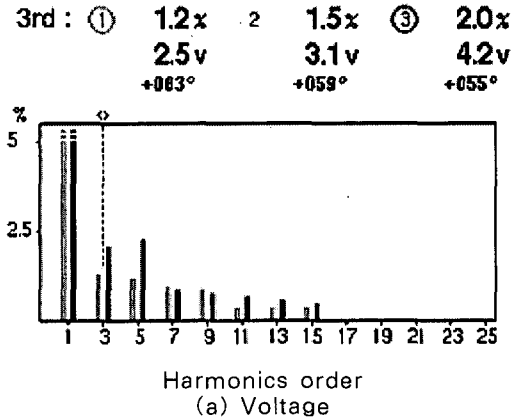

Fig. 3. Spectrum of the voltage and current harmonics on the power lines supplying school facility

A variety of standards and guidelines have been established that specify limits on the magnitude of harmonic current and harmonic voltage distortion at various harmonic frequencies. The IEEE and IEC recommended voltage distortion limits are summarized in Tables 1 and 2, respectively..

Table 2. Compatibility levels for harmonic voltages in LV and MV power systems in IEC(7)

Odd harmonics non multiple of 3		Odd harmonics multiple of 3		Even harmonics	
Order h	Harmonic voltage [%]	Order h	Harmonic voltage [%]	Order h	Harmonic voltage [%]
5	6	3	5	2	2
7	5	9	1.5	4	1
11	3.5	15	0.3	6	0.5
13	3	21	0.2	8	0.5
17	2	> 21	0.2	10	0.5
19	1.5			12	0.2
23	1.5			> 12	0.2
25	1.5				
> 25	0.2+1.3 (25/h)				

NOTE : Total harmonic distortion(THD) : 8% ,
 Medium voltage is between 1(kV) and 35(kV)

Table 1. Voltage distortion limits in IEEE(6)

Bus voltage at the point of common coupling	Maximum for individual harmonic	Total harmonic distortion (THD) (%)
69[kV] and below	3.0	5.0
69[kV] through 161[kV]	1.5	2.5
161[kV] and above	1.0	1.5

Note: High-voltage systems can have up to 2% THD where the cause is an HVDC terminal that will attenuate by the time it is tapped for a user

THDs of the voltage and current on the mains ranged from 1.8 to 2.2[%] and 15.7 to 23.4[%], respectively. Also, the 3rd harmonic distortion factors of each line-to-line voltage were relatively high and ranged from 1.2 to 2.0[%]. But, the distortion factors of the 3rd harmonic current of each line were between 11.3 and 18.7[%] and were much greater than those of the 3rd harmonic voltages. Switch-mode power supplies for personal computers will produce harmonic voltages and currents.

Generally, the voltage THD is less than 5%. The voltage THDs below 5[%] are widely

각종 시설물 전원계통의 전압과 전류고조파 실태

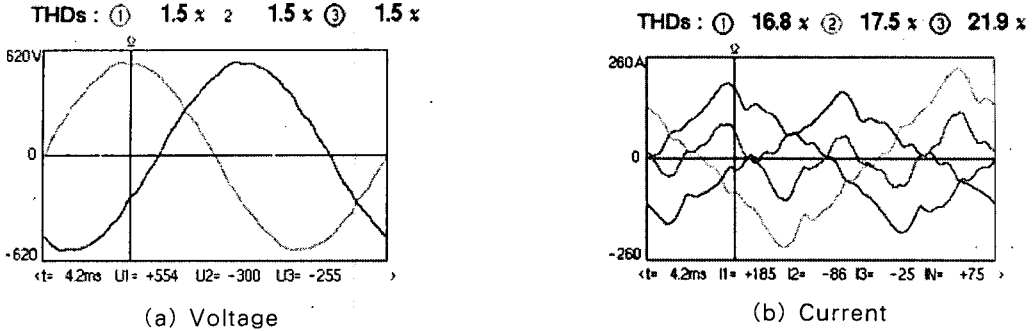

Fig. 4. Typical waveforms of the voltage and current on the power lines for hospital facility

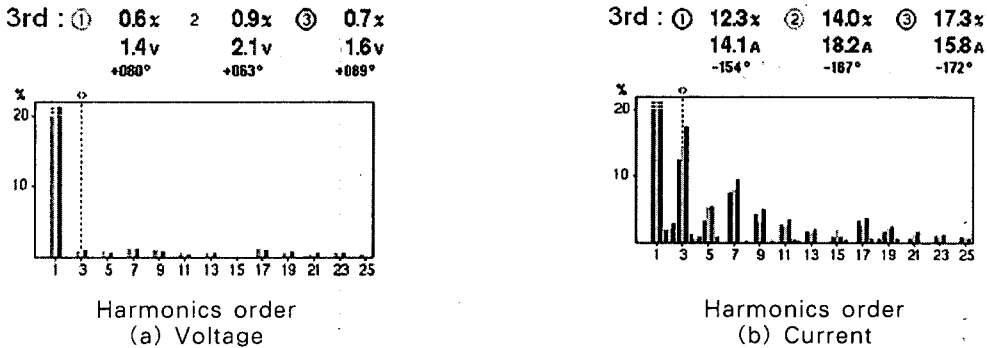

Fig. 5. Spectrum of the voltage and current harmonics on the power lines for hospital facility

considered to be acceptable, but values above 10[%] are definitely unacceptable and will cause problems for sensitive electronic equipments and loads[3]. Harmonics have various adverse effects on power system components and loads. For example, harmonics can cause transformer overheating. Also, some computer-controlled equipments are very sensitive to voltage distortion. Thus it is desirable to compensate voltage harmonic of the power system network under test.

Harmonic disturbances are generally produced by equipments having nonlinear voltage-current characteristics or by periodic and line-synchronized switching of loads. Such equipments may be regarded as sources of harmonic currents. The harmonic currents from the different sources cause harmonic voltage drops across the impedance of the power system network.

(2) Hospital

The electric loads in the hospital mainly consist of the medical facilities such as operation equipments, X-ray photograph system, remedial devices, computer systems, air-conditions, air cleaners, elevators, lighting fixtures, and others. The capacity of the receiving transformer is 200 [kVA] The measurements were performed for an interval of 3:00-4:00PM on November 3, 2003, and then the load factor was approximately 45[%].

Figures 4. and 6. show the distorted voltage and current waveforms due to harmonics and their harmonics spectra on the power lines supplying hospital facility, respectively. In practice, currents can significantly deviate from the sinusoidal waveform due to power line disturbances.

The line-to-line voltage THDs were about 1.5[%] and the current THDs of each line ranged from 16 to 22[%]. The power system distortions

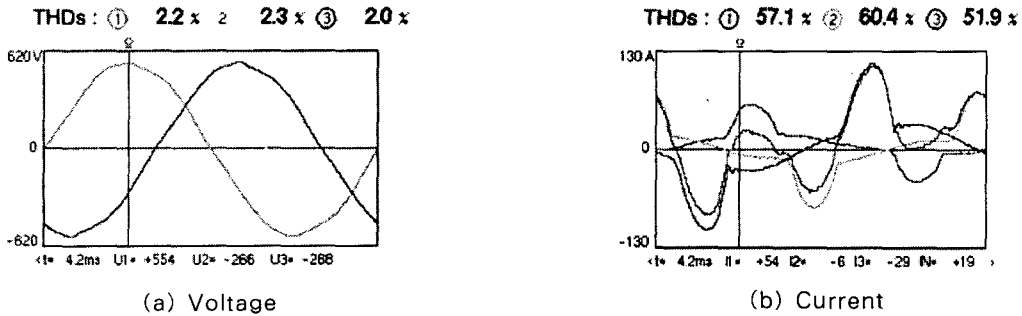

Fig. 6. Typical waveforms of the voltage and current on the power lines of office building

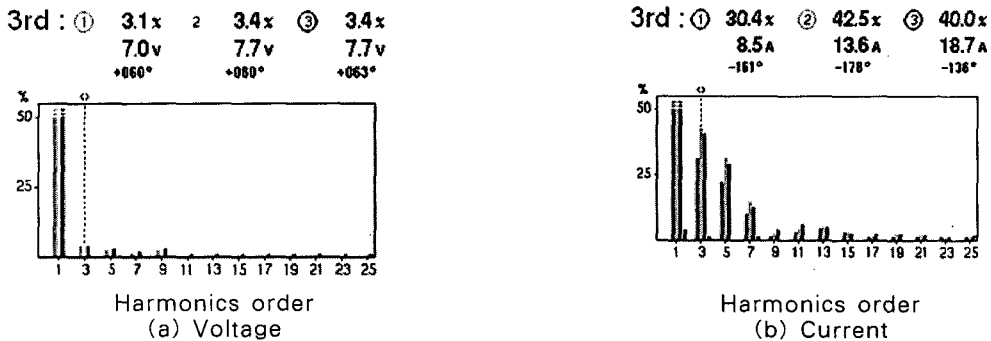

Fig. 7. Spectrum of the voltage and current harmonics on the power lines of office building

are relatively small. Because the harmonic voltages are produced by the product of the harmonic current and the impedance of nonlinear loads, the voltage distortion factors are not in direct proportion to current distortion factors. Harmonic voltages cause high harmonic currents in capacitors because the capacitor impedance is inversely proportional to frequency. Voltage distortions of 5 and 10[%] can increase rms currents by 10 to 50[%].

(3) Office building

The power receiving system of the office building with stores on the ground floor supplies a variety of loads such as PC room, electronic amusement hall, refrigerators, air cleaner, air-conditioners, elevators, fluorescent lighting, TV set, various office supplies, and so on. The measurements were carried out during

4:00-5:00PM on November 6, 2003, and then the power lines supply a 56[kW] load.

In the power system under test, the voltage distortions are usually small and do not present a power quality issue. However, if the impedance of power systems is high, voltage distortion can be high and may give rise to critical problems for sensitive electronic devices and equipments.

Examples of line-to-line voltage and line current waveforms and their harmonics spectrum on the 3-phase, 4-wire power lines of the official building are shown in Figs. 5 and 6, respectively.

The distortion factors of the 3rd- and the 5th-harmonic voltages ranged from 3.1 to 3.4[%] and from 1.9 to 2.1[%], respectively. The maximum value of the 3rd harmonic voltage on the power lines surveyed exceeds its allowable level of 3[%], and that of THD is marginally lower than its allowable level of 5[%]. Current distortions are

각종 시설을 전원계통의 전압과 전류고조파 실태

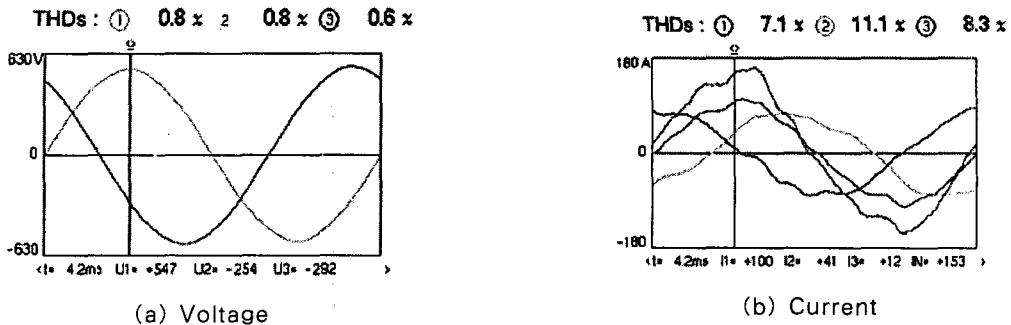

Fig. 8. Typical waveforms of the voltage and current on the power lines of factory

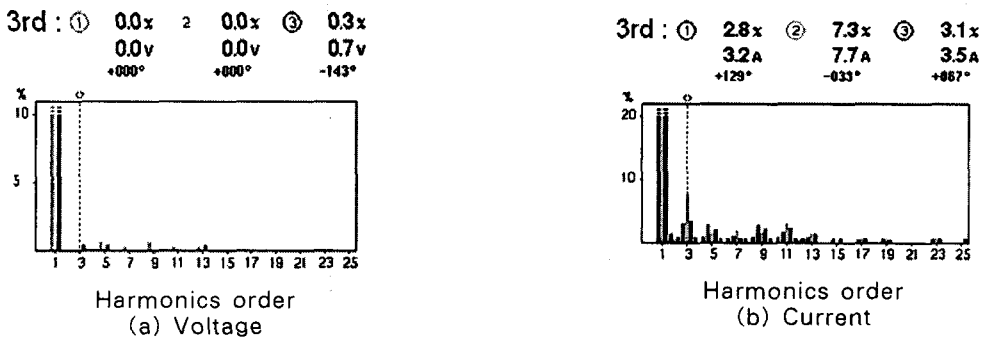

Fig. 9. Spectrum of the voltage and current harmonics on the power lines of factory

dominated by the 3rd harmonic with a magnitude in the range from 30 to 45[%] of the fundamental. Also, the distortion factor of the 5th harmonic current appeared the large value between 21.1 and 31.1[%]. Many personal computers coming into wide use in all modernized social systems have the third harmonic currents greater than 80[%].

(4) Factory

Harmonic components of line currents generated by personal computers and other nonlinear loads are not completely connected because of phase-angle diversity in their phase currents. The factory electric facilities are mainly composed of various loads including electric spinning and weaving machineries, motor controllers, inverters, pumps, fans, air conditioners, incandescent lights, heaters, computer systems, office supplies, and etc. The capacity of the

receiving power transformer is a 225[kVA]. The measurements were carried out in the common operation conditions for a period of 4:00-5:00PM on September 25, 2003. At that time, the power lines supply a 102[kW] load. Harmonic currents are significantly reduced by the installation of many linear loads in the factory.

Table 3. Indicative values for relative harmonic currents as emission limits[7]

Harmonic number h	5	7	11	13	$\sqrt{\sum I_h^2}$
Admissible harmonic current	5 - 6	3 - 4	1.5 - 3	1 - 2.5	6 - 8
$i_h = I_h / I_1 (\%)$					

Therefore, the current THD of total loads is less than 10[%] because of diverse loads of factory.

Table 4. Current distortion limits for general distribution systems(120(V) through 69(kV))(6)

Maximum harmonic current distribution in percent of I_L						
Individual harmonic order(odd harmonics)						
I_g/I_L	$h < 11$	$11 \leq h < 17$	$17 \leq h < 23$	$23 \leq h < 35$	$35 \leq h$	TDD
< 20	4.0	2.0	1.5	0.6	0.3	5.0
$20 < 50$	7.0	3.5	2.5	1.0	0.5	8.0
$50 < 100$	10.0	4.5	4.0	1.5	0.7	12.0
$100 < 1000$	12.0	5.5	5.0	2.0	1.0	15.0
> 0100	15.0	7.0	6.0	2.5	1.4	20.0

Note : Harmonic current limits for nonlinear load connected to a public utility at the point of common coupling with other loads at voltages of 2.4-69(kV). I_x is the maximum short-circuit current. I_L is the maximum fundamental frequency load current. Even harmonics are limited to 25[%] of the odd harmonic limits above. TDD : total demand distortion, harmonic current distortion, in [%] of maximum demand load current (15 or 30 min demand)

Figures 8. and 9. show examples of line-to-line voltage and line current waveforms and their harmonics spectrum on the 3-phase, 4-wire power lines of the small-sized sewing factory, respectively.

The permissible share in the total voltage distortion will generally not be exceeded when appropriate limits are set on the relative harmonic currents. Table 3. gives the indicative values for relative harmonic current limits under simplified evaluation of disturbance emission for the total load of a consumer, where I_h is the total harmonic current of order h caused by the consumer and I is the r.m.s. current corresponding to its agreed power.

Table 4. lists the harmonic current limits based on the size of the loads with respect to the size of the power system to which the loads are connected, where I_n is the maximum harmonic current distortion in percent and h is the individual odd harmonic order.

The ratio I_{sc}/I_n is the ratio of the short-circuit current available at the point of common coupling, to the maximum fundamental load current. The percent impedance $\%Z$ of all transformers

employed in this work ranges from 4.0 to 4.7[%]. It is inferred that the I_{sc}/I_L of the loads lies between 20 and 50[%] when considering the present impedance of transformers and demand factor of load. Distortion factors of voltage harmonics on the power lines of this work were relatively small within the limits recommended by IEEE and IEC Standards. However, the distortion factors of current harmonics were significantly greater than the current distortion limits recommended by IEEE and IEC Standards.

4. Conclusion

We have examined the voltage and current harmonics on low-voltage ac supply mains. The main conclusions are summarized as follows;

Many PC and switch-mode loads lead to significant current distortion and the voltage and current have entirely odd harmonics. The voltage THDs in this work were less than 5[%], and the current THDs of each line ranged from 15 to 60[%]. The current distortion factors are much greater than the limits of IEEE and IEC standards related to harmonics, but the voltage distortion

각종 시설물 전원계통의 전압과 전류고조파 실태

factors appear its allowable level or less than the limits. The further work for obtaining the effective reform measures of current distortions on power lines is required.

This work was financially supported by MOCIE through EIRC program.

References

- [1] H. Akagi, "New Trends in Active Filters for Power Conditioning", IEEE Trans., Ind. Appl. Vol. 32, No. 6, pp.1323-1322, 1996.
- [2] N. Mohan, T. M. Undeland and W. P. Robbins, "Power Electronics", John Wiley & Sons, Inc., 2nd Edition, New York, 1995, pp.354-358, 483-504.
- [3] W. M. Grady and S. Santoso, "Understanding Power System Harmonics", IEEE Power Engineering Review, pp.8-11, Nov. 2001.
- [4] S. Bhattacharya, T.M. Frank, D.M. Divan, and B. Banerjee, "Active Filter System Implementation", IEEE Industry Application Magazine, pp.47-63, Sep./Oct. 1998.
- [5] F. Z. Peng, H. Akagi, A. Nabae, "A New Approach to Harmonic Compensation in Power Systems", IEEE-IAS Conf. Record, pp.874-880, 1988.
- [6] IEEE Industry Applications Society & Power Engineering Society "IEEE Recommended Practices and Requirements for Harmonic Control in Electrical Power System", IEEE Std 519-1992.
- [7] International Electrotechnical Commission, Electromagnetic compatibility(EMC), Part 3: Limits-Section 6: Assessment of emission limits for distorting loads in MV and HV poer systems-Basic EMC publication, IEC 61000-3-6, pp.11-51, 1996.

◇ 저자소개 ◇

이복희 (李福熙)

1954년 6월 29일생. 1980년 2월 인하대 공대 전기공학과 졸업. 1987년 동 대학원 전기공학과 졸업(박사). 1988~1989년 동경대학 생산기술연구소 객원연구원. 1995년 호주 Queensland대학 방문교수. 현재 인하대 공대 전자전기공학부 교수. 인하대학교 차세대고전압 전력기술연구센터 소장.

Tel : (032) 860-7398,

Fax : (032) 875-1276,

E-mail : bhlee@inha.ac.kr.

백영환 (白英煥)

1959년 12월 8일생. 2002년 2월 서울산업대학교 공대 전기공학과 졸업. 2004년 2월 인하대 산업대학원 전기공학과 졸업. 2005년 현재 인하대 대학원 전기공학과 박사과정.

Tel : (032) 860-7398,

Fax : (032) 875-1276,

E-mail : sky4u6006@hanmail.net.