

OPTIMUM AIR PRESSURE FOR AN AIR-CELL SEAT TO ENHANCE RIDE COMFORT

W. S. YOO*, D. W. PARK, M. S. KIM and K. S. HONG

Mechanical Engineering, Pusan National University, Busan 609-735, Korea

(Received 3 March 2004; Revised 15 July 2004)

ABSTRACT—Several air cells are installed in the seat cushion to adjust the stiffness of seat by changing the air pressure. To select proper air pressure in the air cells, two kinds of tests are performed. For the pressure distribution on the seat, the maximum pressure and mean pressure are compared. And for the dynamic ride values, SEAT (Seat Effective Amplitude Transmissibility) values are calculated and compared. These experiments are carried out with three different drivers, three different vehicle speeds on the highway and two different speed on the primary road, and three different air pressures. From the real car tests, optimum air cell pressure depending on the vehicle speed and driver's weight are recommended.

KEY WORDS : Air-cell Seat, Experiments, Air Pressure, Pressure distribution, SEAT values

1. INTRODUCTION

In these days, many electro-mechanical devices are installed in cars to enhance safety. In addition to seat-belts, airbags, and ABS systems, recently collision warning system and GPS system become popular in advanced cars.

Electronic devices such as car navigation systems help drivers to easily find their ways to destination by showing routes in the screen installed in a car, and inform what's going on the ways or which way confronts more traffic jam and so on. These equipments help drivers to easily concentrate their attentions for the situations in front of their cars. Sometimes, a rearview warning system helps driver to avoid a collision in their ways for backward driving such as parking.

In addition to safety, the ride comfort also is one of main issues to define the quality of a car. Seats are required to reduce vibration transmissibility from the road and suspension to the human bodies. Although ride comfort is closely related to human vibration, it in some sense contains some psychological effects. Thus, it varies from person to person even though the same values are detected in a measuring device. Anyway, when ride comfort is defined as a physical quantity and is written as an equation, the ride comfort index is defined as a function of acceleration.

There are many researches to evaluate human vibrations and ride comfort (Janeway, 1948; Griffin,

1986; Griffin, 1990). Among these papers, Griffin's researches (Griffin, 1986; Griffin, 1990) show a nice summary in human vibration. In his paper (Griffin, 1990), definitions of comfort model including vibration axes, magnitudes and frequencies, and VDV (vibration dose values) are well explained.

Researches on human vibration are mainly concerned to the response of human body to the exerting forces, frequencies, force directions, and exposed time. The standardization processes of these research factors are developed as ISO2691 (ISO2691, 1985) and BS6841 (BS6841, 1987).

Emerging Korea as one of the major car manufactures in the world, many groups in Korea actively proceeded researches related to the seat system to enhance the ride quality of Korean passenger cars (Jang, 2002; Kim, 2001; Cheung, 1997; Woo, 1997). Jang (2002) recently proposed an equation to evaluate the discomfort of a seated human body due to the vibration at the seat and the floor. Other researchers (Kim, 2001; Cheung, 1997; Woo, 1997; Kim and Kim, 2005) presented their researches on the evaluation of vibration's environment in the Korean public transportations and ride values of Korean passenger cars.

The comfort in sitting position also depends on the stiffness of the seat foam and the shape of the seat. When the car is not moving, the seat comfort is somewhat related to the pressure distribution on the seat. To get widely distributed pressure on the seat, the pressure sensing systems such as TEKSCAN (www.tekscan.com) or X-sensor (www.xsensor.com) can be used. And when the

*Corresponding author. e-mail: wsyoo@pusan.ac.kr

car is moving, the characteristics of seat are combined to the human vibration and appeared as dynamic seat comfort.

Recently, some advanced seats were announced with air cells in the seat cushion and to adjust seat stiffness depending on the passenger's choice. The previous researches, they just push in or take out airs in the air cells passively. In this research, we developed a new system to automatically adjust the stiffness depending on the drivers weight, vehicle speed, and road conditions. To select proper air pressure in the air cells, pressure distribution and SEAT (Seat Effective amplitude Transmissibility) values are calculated and compared. From the real car tests, optimum air cell pressure depending on the vehicle speed and driver's weight are recommended.

2. PRESSURE DISTRIBUTION IN A SEAT

2.1. Design of Air Cells

Air cells are widely used for patients with paralysis or other disabled diseases. Applying the air cell technology to reduce numbness and fatigue for long-distance truck

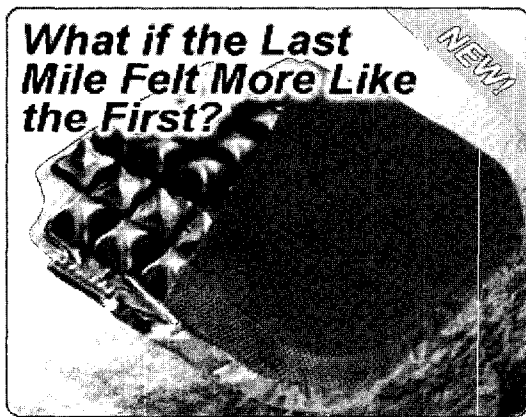

Figure 1. AIRHAWK® comfort seating system.

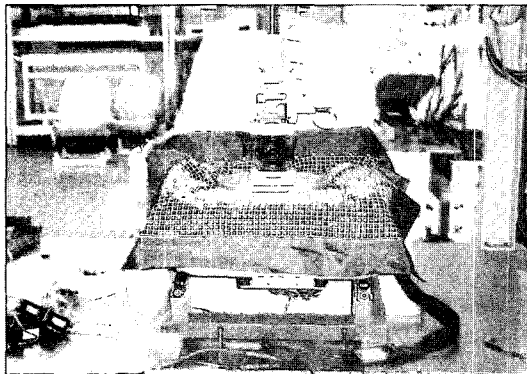

Figure 2. X-sensor system to measure pressure distribution.

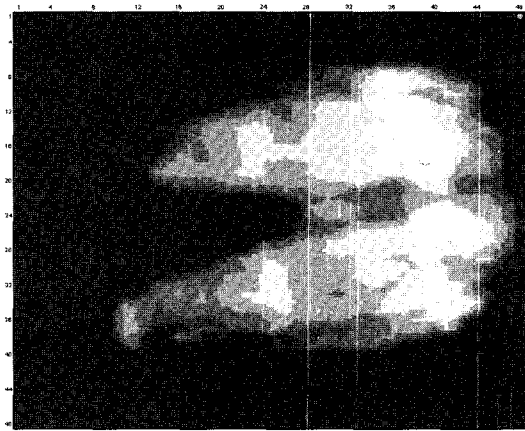

Figure 3. Pressure distribution measured from the X-sensor system.

drivers, AIRHAWK® comfort seat system was proposed (www.rohoc.com/commercial), as shown in Figure 1.

To be applicable for passenger cars, air cells should be designed to fit shape of the seat cushion. In this research, air cells were designed according to the general outline of the seat form, and then seat foam was cut according to the shape of air cells. In this stage, the seat form had cut to have some rooms for the full-air situation in the air cells.

2.2. Range of Pressures in Air Cells

The seat equipped with air cells inside was tested for the pressure distribution, and the pressure distributions were measured with a X-sensor system as shown in Figure 2. In this stage, several kinds of air cell pressures are tested to assign the maximum and minimum air pressures.

Figure 3 shows a typical pressure distribution measured from the X-sensor system. It was curious to find that the pressure distributions of men are not symmetric between right-hand side and left-hand side because of purse in one rear pocket.

2.3. Pressure Control System for Air Cells

Two types of control, passive control and a self-adjusting automatic control, are basically developed in this research. In the passive system, the pressure in each air cell was open to be adjusted by the passenger along his preference in seat stiffness. In the self-adjusting automatic seat, the air cell pressure was automatically adjusted according to the control algorithm.

In the first attempt for a control algorithm in the automatically adjusting air cell seat, the air cell pressure was assigned from a look-up table from real experiments. To select an optimum air cell pressure depending on vehicle conditions and passenger conditions was the main item in this research.

Figure 4 shows an electronic device to supply air

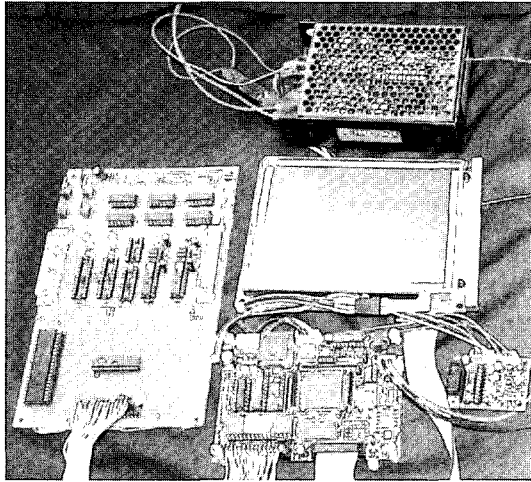

Figure 4. Control system for air cells.

pressure for the air cell control.

3. EVALUATION OF RIDE COMFORT

When a car is running on the roads, the road is acting as white noise containing most frequencies. Passing through the tire, the suspension, and the chassis, the vibration is reduced and transmitted to the floor and the seat track. In these transmitted vibrations, many kinds of vibration modes, pitching, bouncing, shake, shimmy, and harshness are contained. These vibrations are then transmitted to the human body through the seat. The

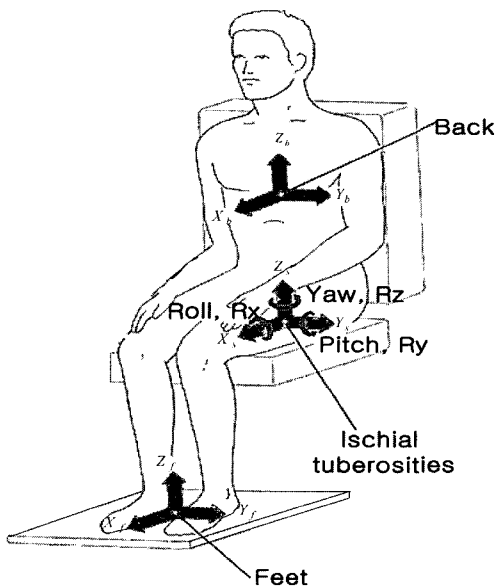

Figure 5. Twelve axes of vibration to measure vibration discomfort.

vibrations transmitted to the seat are then combined to the human vibration characteristics and generated discomfort for the passenger.

3.1. Characteristics and Weightings for Human Vibration
 To measure body vibration of ride comfort, 12 axes are usually used (Kim, 2001) as shown in Figure 5. Twelve axes include the 3 translational and 3 rotational axes on the seat surface, the 3 translational axes at the seat back and the 3 translational axes at the feet. These axes were proposed by the ISVR (Institute of Sound and Vibration Research, <http://www.isvr.soton.ac.uk>), and currently used as a standard axes system in the ISO2631 and BS6841.

The vibration to human body is transmitted to the foot, hip and back from the seat. Human body recognizes these vibrations, but the sensitivity for each vibration is

Table 1. The frequency weighting functions and axis multiplying factors in BS 6841.

Acceleration time history (m/s ²)	Frequency weighting function (BS 6841)	
	Symbol	Axis multiplying factor
Feet (a_{xf})	W_b	0.25
Feet (a_{yf})	W_b	0.25
Feet (a_{zf})	W_b	0.40
Feet (a_{xs})	W_d	1.00
Feet (a_{ys})	W_d	1.00
Feet (a_{zs})	W_d	1.00
Feet (a_{rx})	W_e	0.63
Feet (a_{ry})	W_e	0.40
Feet (a_{rz})	W_e	0.20
Feet (a_{xb})	W_c	0.80
Feet (a_{yb})	W_d	0.50
Feet (a_{zb})	W_d	0.40

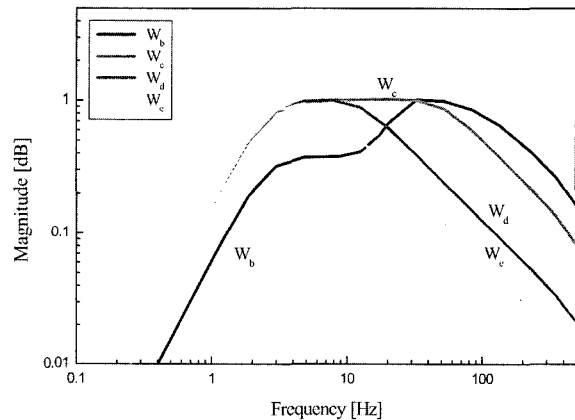

Figure 6. Frequency weightings for a human body.

different. Many researchers investigate the weightings for these vibrations and proposed axis multiplying factors. And the human sensitivities according to the frequency are defined as a frequency weighting functions. Depending on the location and direction, different frequency weighting functions are applied with a multiplying factor shown in Table 1. Figure 6 shows shapes of the frequency weighting functions for a human body.

3.2. Index for Ride Comfort

To quantify the oscillating signal, a RMS (Root Mean Squares) is a widely used value. The RMS of a component can be written as;

$$r.m.s_{component} = \left[\frac{1}{N} \sum_{i=1}^N a^2(i) \right]^{1/2} \quad (1)$$

where $a(i)$ is the acceleration time history of the i th vibration and N is the number of signals considered. The subscript *component* means one of the 12 vibrations according to the 12 axes. It is known that these values do not give good estimate when the motion contains occasional peak values.

A compatible mean of quantifying the severity of high crest factors is to use a vibration dose value (VDV), which is a RMQ (Root Mean Quads).

$$VDV_{component} = \left[\frac{T_s}{N} \sum_{i=1}^N a^4(i) \right]^{1/4} \quad (2)$$

where T_s is the measured time for the vibration.

The overall ride values for the vibration can be obtained by summation of the each component as;

$$r.m.s_{overall} = \left[\sum r.m.s_{component}^2 \right]^{1/2} \quad (3)$$

$$VDV_{overall} = \left[\sum VDV_{component}^4 \right]^{1/4} \quad (4)$$

To compare overall ride values of several seats, the percent vibration is used (Woo, 1997). It is calculated from the difference of overall ride value by dividing the overall ride value of the seat track as shown in equation (5).

Vibration(%) =

$$\frac{ORV_{seat\ contact\ area} - ORV_{vibration\ table}}{ORV_{vibration\ table}} \times 100 \quad (5)$$

where *ORV* means the overall ride value and the subscript means the location of the vibration measurement point. In the equation (5), *ORV* value is calculated from frequency weighting functions and axes multiplying factors. For the comparison of real cars, the *ORV* of the vibration table is replaced to the *ORV* of the seat track.

SEAT (Seat Effective Amplitude Transmissibility) value for the vertical vibration is determined using the

PSD (Power Spectral Density) of the seat $\{P_{ss}(f)\}$ and the PSD of the floor $\{P_{ff}(f)\}$ as;

$$S.E.A.T. = \left[\frac{\int_{f_0}^{f_1} (P_{ss}(f) w_b(f)^2) df}{\int_{f_0}^{f_1} (P_{ff}(f) w_b(f)^2) df} \right]^{1/2} \quad (6)$$

where $w_b(f)^2$ is the frequency weighting function. If the SEAT value is less than 1, the vibration level on the seat is less than the floor, which means seat is effective to reduce the vibration. If the SEAT value is greater than 1, the seat is ineffective to reduce the vibration. Therefore, the smaller SEAT value is, the better seat efficiency is.

4. EXPERIMENTAL RESULTS FOR OPTIMUM AIR CELL PRESSURE

4.1. Experimental Setup and Test Conditions

In this study, a real experiment is carried out with three persons to test the ride comfort. The car is tested on the



(a) Passenger for the ride comfort test

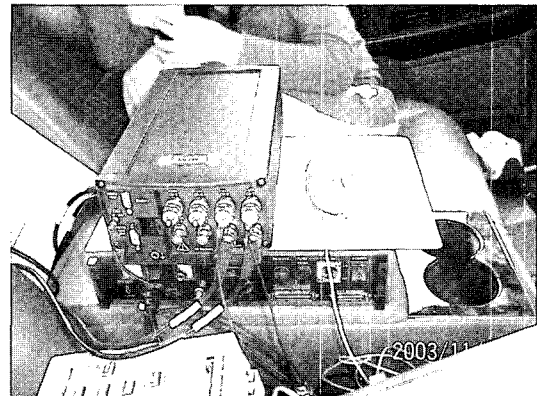

(b) Equipments to measure accelerations

Figure 7. Measurement of accelerations for to calculate ride comfort.

highway from Busan to Daejeon. And for a non highway road test, the car is also tested on primary roads near the Busan metropolitan city. Three persons are selected depending on their weights, i.e., 65 kg, 75 kg, and 85 kg.

Figure 7. shows the test person sit on the air cell seat and equipments to measure ride comfort. To get more reliable test results, the same experiments (same vehicle speed, same road conditions, and same air cell pressures) are repeated three times.

For each person, the speeds are changed to three different values, i.e., 80 kph, 100 kph, and 120 kph. The

air cell pressures are also changed to three different values, i.e, 0.02 kg/cm², 0.05 kg/cm², and 0.08 kg/cm².

4.2. Optimum Air Cell Pressure from Pressure Distribution
Figure 8 show typical results of pressure distribution for the 65 kg person on the air cell seat. Although there are some differences depending on the vehicle speed, the air cell pressure of 0.05 kg/cm² gives the lowest average pressure. When the average pressure is low, most passengers feel more comfortable on the seat. From this result, thus, it can be said that the air cell pressure of 0.05 kg/cm² is best for 65 kg person among the three pressure applied to the air cell.

The same experiments are repeated to get results for 75 kg person and 85 kg person. The obtained results are summarized in the Table 2. From Table 3, it can be said that the lower pressure is recommended for heavy person. It may come from the fact that the lower pressure make the contact area more wider.

4.3. Optimum Air Cell Pressure from SEAT Values

For the measurement of human vibration, the B&K 4322 is installed at the bottom of the hip, B&K4321 sensors in the back of the seat, as shown in Figure 7. The sensor at the hip is located at the ischiadic tuberosity and the sensor at the back is located at the lumbar support.

Two amplifiers were used combining a 4-channel NEXUS and a 8-channel B&K 5974. The output signals were recorded for 1 minute with 2.5 kHz sampling rate by a 16-channel digital recorder Sony PC216Ax. Each accelerometer is connected to the amplifier and the signals are recorded in digital tape recorder SONY-PC216A. The recorded signals are stored in the PC with PCSCAN program with a digital interface SONY PCIF260, and the stored data is processed to calculate ride comfort (Janeway, 1948).

Three vehicles are compared for the ride values in the cement and asphalt roads. The RMS values and VDV are compared for the ride comfort. Since the roads contain many curves, the x-direction (longitudinal) and y-direction (lateral) values are appeared not so small. The procedure to calculate component ride values and overall ride values are in Figure 9. The term 'r.s.s.' in Figure 9 means a root square sum of three r.m.s. components. The vibrations are measured at the two roads with various

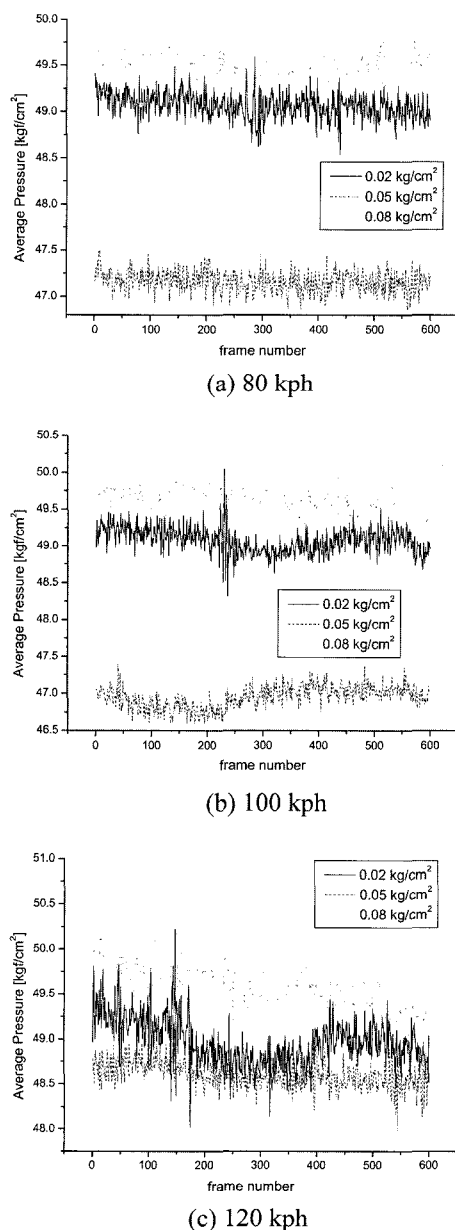

Figure 8. Measurement of average pressure depending on the vehicle speed (in case of 65 kg person).

Table 2. Optimum Pressure from pressure distribution.

Speed \ Weight	Weight 65 kg	Weight 75 kg	Weight 85 kg
80 kph	0.05	0.02	0.02
100 kph	0.05	0.02	0.02
120 kph	0.05	0.02	0.02

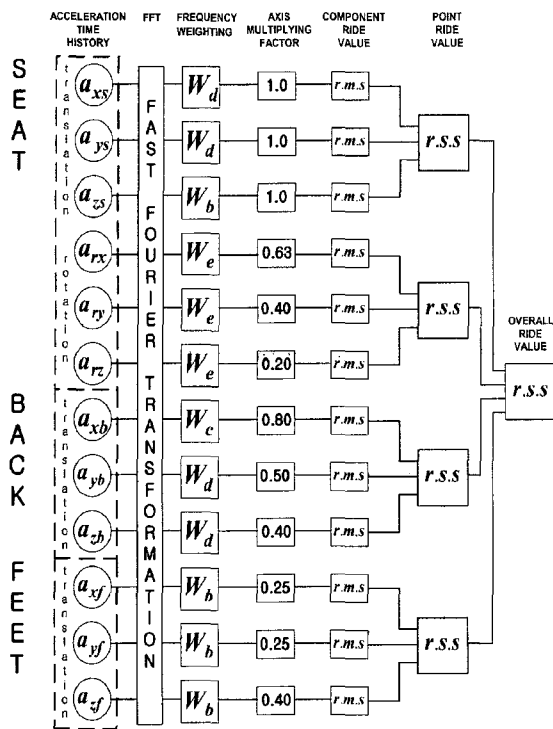

Figure 9. Procedure for calculating overall ride values.

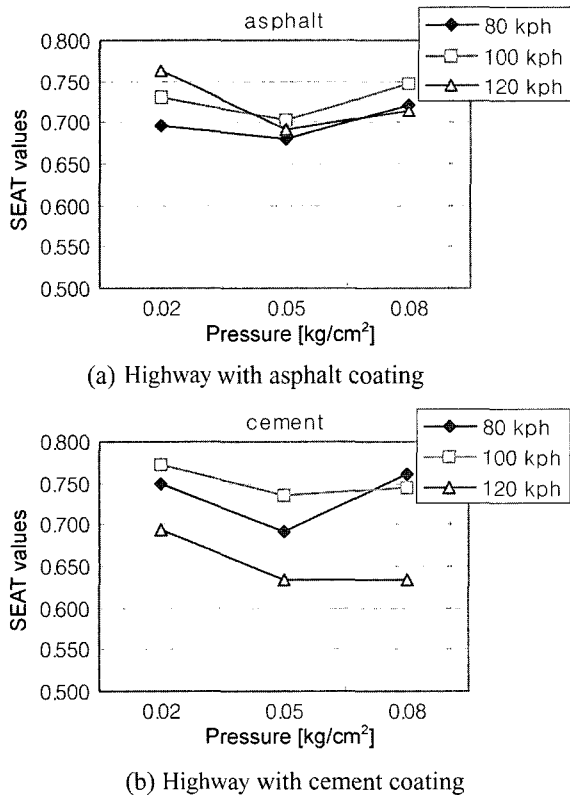

Figure 10. Measurement of SEAT values (in case of 65 kg person).

Table 3. Optimum Pressure from SEAT values.

Speed \ Weight	65 kg	75 kg	85 kg
80 kph	0.05	0.02	0.02
100 kph	0.05	0.02	0.02
120 kph	0.05	0.02	0.02

speeds.

Plugging the overall RMS values to the SEAT values equation (6), the SEAT values are calculated and compared as shown in Figure 10. Figure 10 shows are typical values for the 65kg person on the air cell seat. Although there are some deviations depending on the vehicle speed, the air cell pressure of 0.05 kg/cm² gives the lowest SEAT values.

The same experiments are repeated to get results for 75 kg person and 85 kg person. The obtained results are summarized in the Table 3. From Table 3, it can be also said that the lower pressure is recommended for heavy person. It may come from the fact that the lower pressure make the contact area more wider.

5. CONCLUSION

In this paper, an air cell seat was proposed to enhance the ride comfort in the seat. We developed a new system to adjust the seat stiffness depending on the driver's weight, vehicle speed, and road conditions. Seat pressure distribution and SEAT (Seat Effective amplitude Transmissibility) values were calculated and compared. And then a default value of air cell pressure was selected for an automatic adjustment. Three different speeds (80 kph, 100 kph, 120 kph) with three kinds of weights (65 kg, 75 kg, 85 kg) are tested to choose an optimum air cell pressure. It was shown from the experiments that the air cell pressures was mainly dependent on the passenger weight.

ACKNOWLEDGEMENT—The authors would like to thank financial support in the Ministry of Science and Technology of Korea in the form of grant (M1-0203-00-0017) under the NRL (National Research Laboratory) and KATECH (Korea Automotive Technology Institute).

REFERENCES

BS6841 (1987). Guide to measurement and evaluation of human exposure to whole body mechanical vibration and repeated shock.
 Cheung, W. S., Cho, Y. G., Yoon, Y. S., and Park, S. J. (1997). Evaluation of the ride values of passenger cars on the unevenness and endurance roads. *Trans. of the*

- Korean Society of Noise and Vibration Engineering* **7**, 6, 1025–1030.
- Griffin, M. J. (1986). Evaluation of vibration with respect to human response, *SAE Paper No.* 860047.
- Griffin, M. J. (1990). *Handbook of Human Vibration*. Academic Press.
- Gurram, R. and Vertiz, A. M. (1997). The Role of automotive seat cushion deflection in improving ride comfort. *SAE Paper No.* 970596.
- ISO2631/1-3 (1985). Evaluation of human exposure to whole-body vibration.
- Janeway, R. N. (1948). Vehicle vibration limits to fit the passenger. *SAE Journal*, **56**.
- Jang, H. K. (2002). Proposal of an equation for the evaluation of discomfort of a seated human body due to the differential vertical vibration at the seat and the floor. *Trans. Korean Society of Noise and Vibration Engineering* **12**, **8**, 626–631.
- Jeong, Y. (1999). Passenger safety analysis using MADYMO with scaled korean dummy models. Master thesis, *Hanyang University*, Korea.
- Kim, J. K., Hong, D. P., Choi, B. J., and Cheung, W. S. (2001). A study on the evaluation of vibration's environment in the korean public transportations based on the human vibration. *Trans. Korean Society of Noise and Vibration Engineering* **11**, **7**, 267–274.
- Kim, W. Y. and Kim, D. K. (2005). Improvement of ride and handling characteristics using multi-objective optimization techniques. *Int. J. Automotive Technology* **6**, **2**, 141–148.
- KRISS (Korea Research Institute of Standards and Science, 1977). National Anthropometric Survey of Korea 1997, KRISS-97-114-IR.
- Oh, K. (2002). Real-time analysis of occupant motion for vehicle simulator. Master thesis, *Pusan National University*, Korea.
- Woo, C. K., Cheung, W. S., Park, S. J., and Kim S. H. (1997). Ride quality assessment of automotive seats by simultaneous 3-Axis Excitation. *Trans. Korean Society of Noise and Vibration Engineering* **7**, **1**, 143–152.
- X-sensor, <http://www.xsensor.com>