

Adaptive Parallel Decomposition for Multidisciplinary Design

Hyung-Wook Park

*Research Engineer, R & D Division for Hyundai Motor Company,
772-1 Changduk-Dong, Hwasung-Si, Kynnggi-Do, Korea*

Se J. Lee

*Associate Professor, Department of Mechanical Engineering,
The University of Seoul, Seoul 130-743, Korea*

Hyun-Seop Lee

*Research Assistant, the Center of Innovative Design Optimization Technology, Hanyang University,
17 Haengdang-Dong, Sungdong-Gu, Seoul 133-791, Korea*

Dong-Hoon Choi*

*Director, the Center of Innovative Design Optimization Technology Hanyang University,
17 Haengdang-Dong, Sungdong-Gu, Seoul 133-791, Korea*

The conceptual design of a rotorcraft system involves many different analysis disciplines. The decomposition of such a system into several subsystems can make analysis and design more efficient in terms of the total computation time. Adaptive parallel decomposition makes the structure of the overall design problem suitable to apply the multidisciplinary design optimization methodologies and it can exploit parallel computing. This study proposes a decomposition method which adaptively determines the number and sequence of analyses in each sub-problem corresponding to the available number of processors in parallel. A rotorcraft design problem is solved and as a result, the adaptive parallel decomposition method shows better performance than other previous methods for the selected design problem.

Key Words : Parallel Decomposition, Scheduling, Rotorcraft Design, Multidisciplinary Design Optimization (MDO)

Nomenclature

- N : The number of sub-problems
 N_t : The total number of analyses
 p_i : The i -th analysis module
 p_k^i : The i -th analysis in k -th sub-problem
 n_k : The number of analyses in k -th sub-problem
 C_U, C_L : The amount of information transferred between sub-problems in upper and lower triangular regions

- b_k : The sum of feedback couplings of the k -th sub-problem

1. Introduction

An engineering design task involves a number of multidisciplinary analyses whose disciplines are usually coupled. Multidisciplinary Design Optimization (MDO) is a solution method which provides an optimum solution satisfying multiple disciplines simultaneously. Some of the well-known MDO methodologies developed are the Multidisciplinary Feasible (MDF) method, Individual Discipline Feasible (IDF) method, and Collaborative Optimization (CO).

As the number of disciplines involved increases, multidisciplinary analysis or design spends

* Corresponding Author,

E-mail : dhchoi@hanyang.ac.kr

TEL : +82-2-2290-0443; FAX : +82-2-2291-4070

Director, the Center of Innovative Design Optimization Technology Hanyang University, 17 Haengdang-Dong, Sungdong-Gu, Seoul 133-791, Korea. (Manuscript Received October 23, 2003; Revised February 5, 2004)

much longer computation time to resolve the couplings among the disciplines. Therefore, an efficient way of decomposition and scheduling of the disciplines is required.

Several ways of scheduling the execution sequence by changing the order of the analyses have been proposed to reduce design cycle time and cost by Rogers and Barthelemy (1992), Rogers and Bloebaum (1994), Altus et al.(1995), and Rogers et al.(1999). These methods are basically sequential decomposition methods, and are known to be inefficient for IDF or CO methods because they do not consider parallel processing.

A couple of methods for determining optimal decompositions have also been developed. Kusiak and Wang (1993) used a branch-and-bound algorithm to minimize the variables which appear in more than one sub-problem subject to constraints on the number of tasks in a sub-problem. Michelena and Papalambros (1994) proposed a network reliability algorithm to minimize the size of the sub-problems while keeping the amount of information transferred between the sub-problems small.

Park et al.(2002) suggested a parallel decomposition method using a genetic algorithm to minimize both the amount of information transferred between the sub-problems and the number of total feedback couplings in sub-problems with the number of analyses in each sub-problem given. Park et al.(2003) also proposed the system decomposition technique that acquires Pareto set as a solution according to weight function.

This study proposes an adaptive method for decomposition and scheduling of multidisciplinary design problems. The method implements an expanded chromosome which represents the positions of decomposition in a multi-objective genetic algorithm. A rotorcraft design is chosen as a good application example because the optimization of such a rotorcraft requires long computation time due to feedback couplings. It consists of 18 coupled analyses. This study decomposes the problem and applies MDO methodologies to investigate the effectiveness of the proposed method.

2. Adaptive Parallel Decomposition Method

While the sequential decomposition method determines the sequence of analyses to minimize the repeated calculation in feedback couplings, the parallel decomposition method considers two aspects at the same time, which are feedback couplings in sub-problems and the couplings between sub-problems.

A typical design structure matrix of a decomposed system is shown in Fig. 1. The feedback couplings in sub-problems are b_1 through b_N and can be expressed as follows :

$$b_k = \sum_{i=l_k}^{u_k} \sum_{j=l_k}^{i-1} \{ (i-j) \cdot DSM(i, j) \} \quad (1)$$

where $l_k = \sum_{p=0}^{k-1} n_p + 1$, $u_k = \sum_{p=1}^k n_p$, $n_0=0$.

In Eq. (1), using the Design Structure Matrix (DSM) representation, the value of $DSM(i, j)$ is assigned as one if the output of the i -th analysis is fed into the input of the j -th analysis, or zero otherwise.

As the amount of information transferred between sub-problems is smaller, the total calculation time can be shortened. These amounts, c_U and c_L can be represented as follows :

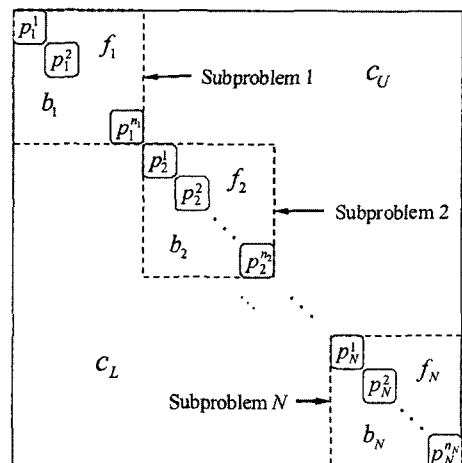

Fig. 1 Design structure matrix of a decomposed system

$$c_U = \sum_{i=1}^{N_t-1} \sum_{j=i+1}^{N_t} DSM(i, j) - \sum_{k=1}^N \sum_{i=l_k}^{u_k-1} \sum_{j=i+1}^{u_k} DSM(i, j) \quad (2)$$

$$c_L = \sum_{i=2}^{N_t} \sum_{j=1}^{i-1} DSM(i, j) - \sum_{k=1}^N \sum_{i=l_k+1}^{u_k} \sum_{j=l_k}^{i-1} DSM(i, j) \quad (3)$$

where $N_t = \sum_{p=0}^N n_p$.

The adaptive parallel decomposition method determines where to decompose and how to reorder with the number of sub-problems N given by simultaneously minimizing the sum of feedback couplings in sub-problems (F_1), the amount of information transferred between sub-problems (F_2) and the variation of computation times among sub-problems (F_3). The variation of computation times F_3 is imposed as the third objective because we can not usually obtain an optimum design structure when the computation time of each analysis varies too much. These three objective functions are formulated as Eqs. (4), (5), and (6), respectively.

$$F_1 = \max_{k=1, \dots, N} (b_k) \quad (4)$$

$$F_2 = \max(c_U, c_L) \quad (5)$$

$$F_3 = \max_{k=1, \dots, N} (t_k) - \min_{k=1, \dots, N} (t_k) \quad (6)$$

where $t_k = \sum_{i=l_k}^{u_k} DSM(i, i)$.

This study employs a multi-objective genetic algorithm (MOGA) to obtain all the Pareto optima at once. A chromosome consists of an integer vector of length N_t for scheduling and an additional integer vector of length $N-1$ for decomposition, where N_t is the number of total analyses and N is the number of sub-problems assigned. It is called an expanded chromosome. Grefenstette's subtour-chunk operation is employed for the crossover of the first part of the chromosome, which is described in Gen and Cheng (1997), and an arithmetic operation for the crossover of the last part. The subtour-chunking operator works by alternatively selecting segments (chunks) from the two parent chromosomes and incorporating those into the offspring. The chunks are placed in the offspring in approximately the same position that they occupied

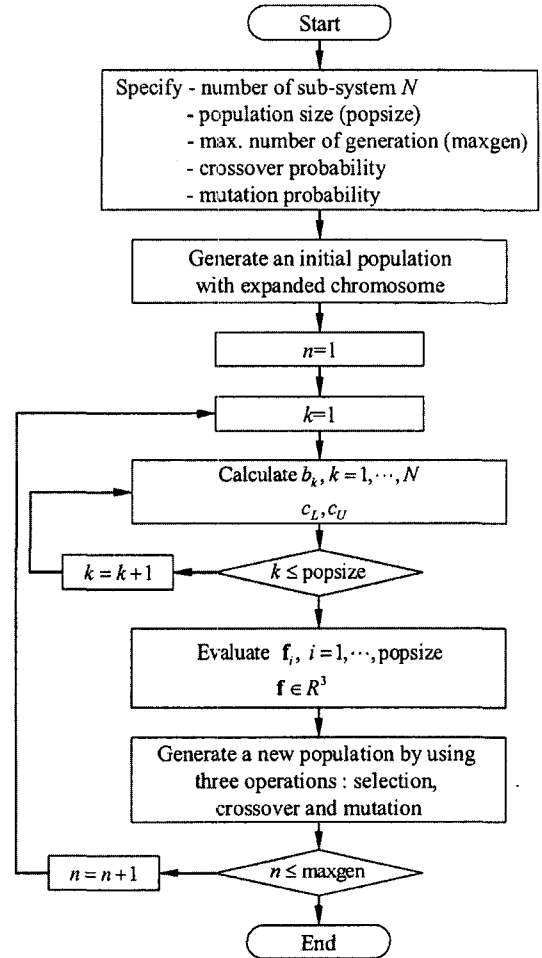

Fig. 2 Flowchart of the adaptive parallel decomposition algorithm

in the parent chromosome. Conflicts are resolved by trimming the chunks and by sliding them to the right and to the left to make them fit.

The proposed method can be summarized as the flowchart in Fig. 2. The algorithm can determine the number and sequence of analysis modules in every sub-problem corresponding to the available number of processors.

3. Multidisciplinary Rotorcraft Design

The rotorcraft design problem (Park, 2003) is chosen as a good application example for the proposed method because the optimization of

such a rotorcraft requires long computation time due to feedback couplings. This study decomposes the problem and applies MDO methodologies to investigate the effectiveness of the developed method.

The problem consists of 18 analysis modules which are coupled. In addition to the couplings between aerodynamics and structural analysis as in the conventional aircraft design, air flow analysis and dynamic characteristics due to rotation and elastic behavior of rotor blades are also coupled in the rotorcraft design. Each analysis module has been developed so that it is composed of a separate analysis code and input/output structure, and the main control program executes it by transferring input/output data files between the analysis modules. Such modular development can obtain many advantages in quality assurance of each module, substitution with a commercial component or extension of an existing module.

Figure 3 depicts the data flow in the rotorcraft analysis, which shows a large amount of couplings between the analysis modules. Each rectangle means an analysis module and arrows between rectangles indicate that outputs of previous module transfer to the latter module.

An initial design structure matrix is shown in Fig. 4 with the amount of time required for each analysis. The numbers at coupling nodes (intersection points) are the numbers of coupling variables and these values represent the strength of coupling between two modules. Fig. 5 shows the result of sequential decomposition. Compared to the initial DSM in Fig. 4, the sum of feedback couplings is reduced from 180 to 45 by 75%.

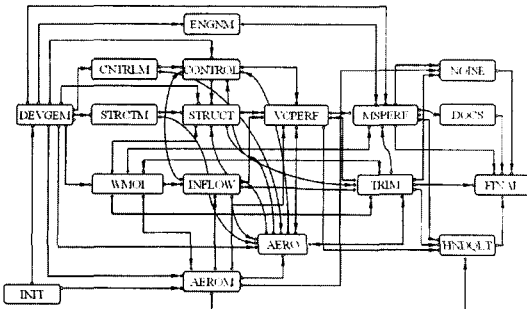

Fig. 3 Data flow in the rotorcraft analysis

Figure 6 shows the result of the adaptive parallel decomposition for the case in which the weighting factor of 0.4 is assigned for F_1 in Eq. (4) representing feedback coupling, 0.4 for representing the amount of information transferred between sub-problems, and 0.2 for F_3 in

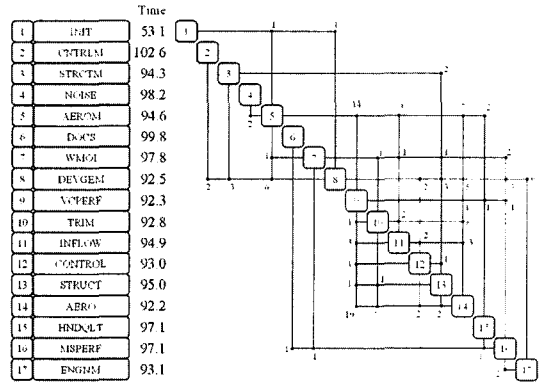

Fig. 4 Initial DSM for the rotorcraft problem

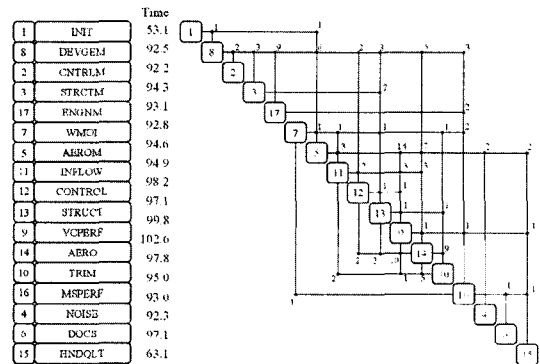

Fig. 5 Result of sequential decomposition

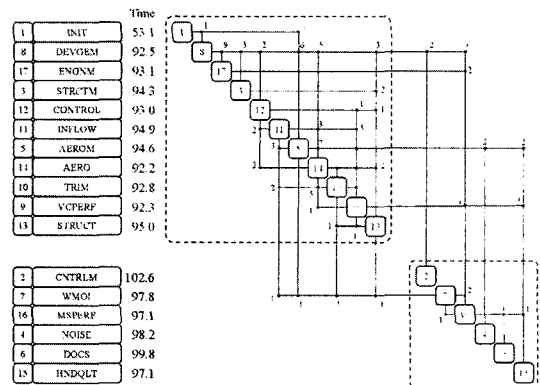

Fig. 6 Result of adaptive parallel decomposition

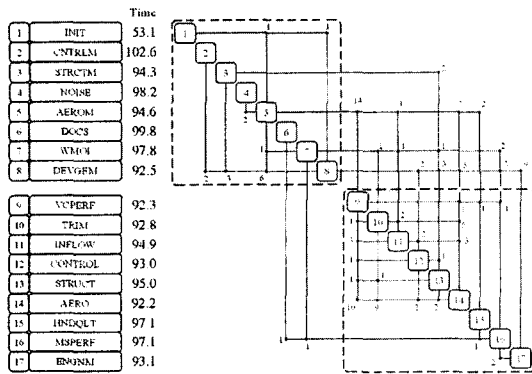

Fig. 7 Decomposition of initial DSM

Eq. (6) representing the variation of computation times among sub-problems. This result is compared with the DSM in Fig. 7 generated by decomposing the initial DSM into one sub-problem with 8 analysis modules and the other with 9 analysis modules. The DSM in Fig. 7 would be the result of a reasonable decomposition if one is requested to decompose the initial DSM into two.

Compared to the decomposed initial DSM in Fig. 7, the maximum sum of feedback couplings in sub-problems (F_1 in Eq. (4)) is dramatically reduced from 161 to 28 by 83% and the maximum of the amount of information transferred between sub-problems in upper and lower triangular regions (F_2 in Eq. (5)) is reduced from 50 to 17 by 66% even though the difference in computation time among sub-problems (F_3 in Eq. (6)) increases from 0.115 sec to 0.988 sec.

The multidisciplinary optimization problem for the rotorcraft design formulated in this study is determining four design variables in order to minimize the gross weight of the rotorcraft while simultaneously satisfying six constraints. The design variables are tip speed, main rotor disk loading, main rotor solidity ratio, and main rotor blade twist angle, and the six constraints are imposed on total shaft power required, calculated noise of helicopter, direct operating cost, fuselage angle of attack, and autorotation entry time.

The problem is solved using three methods listed in Table 1. The MDF method is applied to the initial DSM in Fig. 4 and the sequentially decomposed DSM in Fig. 5 in Case 1 and Case 2,

Table 1 Three methods of solving the rotorcraft design problem

	DSM	MDO method
Case 1	Fig. 4	MDF
Case 2	Fig. 5	MDF
Case 3	Fig. 6	IDF

respectively, and the IDF method is applied to the DSM in Fig. 6, decomposed by using the proposed method, in Case 3.

For all three cases, either the modified method of feasible direction (MMFD) or sequential quadratic programming (SQP) in DOT (Vanderplaats, 1995) is employed as an optimization tool. We tried these two to investigate the effect of the optimization tool employed. The optimum objective function values for the three cases are found to converge to the same optimum within a 2% difference. Defining the pseudo-CPU time as the product of the number of calls and the computation time for each analysis module, the pseudo-CPU time for cases 1, 2 and 3 are found to be 498.0, 335.7, and 299.0 sec for MMFD and 379.4, 204.7, and 192.3 sec for SQP, respectively. The comparison of each pseudo-CPU time clearly shows that Case 3 requires the least time, regardless of the optimization tool employed.

4. Concluding Remarks

This study proposed the adaptive parallel decomposition method and applied it to the rotorcraft design, and generated an efficient DSM as a design procedure. Then, a multidisciplinary optimization problem for the rotorcraft design was formulated and solved using three methods. The result assures that the adaptive parallel decomposition method is more efficient than other previous methods for the rotorcraft design.

Acknowledgment

This research was supported by the Center of Innovative Design Optimization Technology (iDOT), Korea Science and Engineering Foun-

ation.

References

- Altus, S. S., Kroo, I. M. and Gage, P. J. 1995, "A Genetic Algorithm for Scheduling and Decomposition of Multidisciplinary Design Problems," *Advances in design automation, ASME paper* 95-141.
- Gen, M. and Cheng, R. 1997, *Genetic Algorithms and Engineering Design*, pp. 234~248.
- Kusiak, A. and Wang, J. 1993, "Decomposition of the Design Process," *ASME Journal of Mechanical Design*, Vol. 115, pp. 687~695.
- Michelena, N. F. and Papalambros, P. Y. 1994, "A Network Reliability Approach to Optimal Decomposition of Design Problems," *Advances in Design Automation, ASME, New York* Vol. 2, pp. 195~204.
- Park, H. W., Kim, M. S., Choi, D. H. and Mavris, D. N., 2002, "Optimizing the Parallel Process Flow for the Individual Discipline Feasible Method," *9th AIAA/ISSMO Symposium and Exhibit on Multidisciplinary Analysis and Optimization*, September 4-6.
- Park, H. W., Kim, M. S., and Choi, D. H. 2003, "A System Decomposition Technique Using a Multi-Objective Genetic Algorithm," *KSME*, Vol. 27, No. 4, pp. 499~506.
- Park, H. W. 2003, "A Parallel Decomposition Method for Multidisciplinary Design Optimization Based on a Multiobjective Genetic Algorithm," Ph. D. Thesis, Hanyang University, School of Mechanical Engineering.
- Rogers, J. L. and Barthelemy, J. -F. M., 1992, "Enhancements to the Design Manager's Aid for Intelligent Decomposition (DeMAID)," *AIAA paper* No. 92-4809.
- Rogers, J. L., and Bloebaum, C. L. 1994, "Ordering Design Tasks Based on Coupling Strength," *AIAA paper* No. 94-4362.
- Rogers, J. L., McCulley, C. M. and Bloebaum, C. L. 1999, "Optimizing the Process Flow for Complex Design Projects," *Design Optimization : International Journal for Product & Process Improvement*, Vol. 1, No. 3, pp. 281~292.
- Vanderplaats, G. N. 1995, *DOT Users Manual Version 4.20*, Vanderplaats Research & Development, Inc.