

Electrodeposition of ^{241}Am and ^{244}Cm in Spent Nuclear Fuel Samples for Alpha-Spectrometry

Kihsoo Joe,[§] Chang-Heon Lee, Byung-Chul Song, Young-Shin Jeon, Won-Ho Kim, and Jeong-Kee Suh[†]

Korea Atomic Energy Research Institute, 150 Dukjin Dong, Yusong, Daejeon 305-353, Korea

[†]Korea Research Institute of Standards and Science, P.O. Box 102, Yusong, Daejeon 305-600, Korea

Received November 18, 2002

Key Words : Electrodeposition, Alpha-Spectrometry, ^{241}Am , ^{244}Cm , Spent nuclear fuel

Determination of fission products and actinide elements produced during irradiation in a nuclear power reactor is of importance for the chemical characterization of the spent nuclear fuels. Especially, the exact amount of transuranium elements, such as Np, Pu, Am, Cm and their isotopes, are useful to understand the burn-up behavior of the fuels because the isotopes of these elements are produced and decay by various pathways during irradiation and cooling. The radioactive material samples containing alpha-emitting nuclides should be handled in a shielded facility. Consequently, the analytical method for these materials, including sample pretreatment, is limited to some extent compared with that for non-radioactive samples. Generally, the determination of the actinides in neutron irradiated samples is widely performed by alpha-spectrometry after separation by ion exchange or solvent extraction. Thermoionization mass spectrometry is also widely used to measure isotope ratios after separation of the elements by ion exchange chromatography. Several methods have been reported for the electrodeposition of actinides in electrolyte buffer solutions, such as mixed oxalate-chloride matrix,¹ $\text{NaHSO}_4\text{-H}_2\text{SO}_4\text{-NH}_4$ buffer system,² ammonium oxalate-ammonium sulfate,³ isopropanol medium⁴ and $\text{NaHSO}_4\text{-Na}_2\text{SO}_4$ matrix,⁵ since Talvitie's method⁶ using ammonium sulfate was introduced in 1972. However, most of these methods were applied for the electrodeposition of actinides in environmental samples containing trace amount of nuclides. Of these methods, the matrix of $\text{NaHSO}_4\text{-Na}_2\text{SO}_4$ was selected as an electrolyte because this system has an advantage over pH adjustment, which is controlled only by the concentrations of the NaHSO_4 and Na_2SO_4 solutions, and also has not been applied for Am and Cm in spent nuclear fuel samples. This method is especially convenient to handle the radioactive samples in a shielded space because no additional pH adjustment with acid or base is required.

We tried the electrodeposition of ^{241}Am and ^{244}Cm in spent nuclear fuel sample solutions in 0.1 M $\text{NaHSO}_4\text{-0.53 M Na}_2\text{SO}_4$ matrix and then determined these nuclides by alpha-spectrometry. The sample solutions had been taken from uranium fuel solutions after group separation by extraction chromatography with diethylenetriaminepentaacetic acid (DTPA)-lactic acid as an eluent. Accordingly, in this work the effect of DTPA in the electrodeposition process of Am has been studied additionally.

Experimental Section

Apparatus and reagents. The Alpha-spectrometric system with 300 mm² silicon surface barrier detector was an Alpha-King module (Model 676A, EG & ORTEC company). The gross alpha-counting system consisting of plastic scintillator and mini-scaler (Model MS-2, Eberline Instrument Corporation, New Mexico, USA) was used for the measurement of gross alpha-activity. As shown in Figure 1, the electrodeposition device comprised a deposition cell of polypropylene material (inner diameter 2 cm \times height 8 cm), a planchet disc of stainless steel (diameter 1 inch \times thickness 0.5 mm) and a platinum electrode (diameter 1 mm), which was installed onto the steel support and connected with a constant power supply (50V, 3A). The pH meter was a Minisis 6000 model from Tacussel company. NaHSO_4 and Na_2SO_4 for the preparation of sodium hydrogen sulfate-sodium sulfate solution were extra pure grade from Junsei Chemicals Co. (Tokyo, Japan) and Merck Co. (Darmstadt, Germany), respectively. H_2SO_4 , HClO_4 and HNO_3 used for the decomposition of organic compounds in sample pretreatments and NH_3 used for the neutralization of the electrolyte at the end of the time for electrodeposition were all reagent grade from the Merck Co. Diethylenetriaminepentaacetic acid (DTPA) from Aldrich Chemical Co. (Milwaukee, WI, USA) as a chelating agent was used to examine the effect of electrodeposition yields on Am. Standard solutions of ^{241}Am (0.8277×10^5 Bq/g) and ^{244}Cm (0.7356×10^5 Bq/g) were the

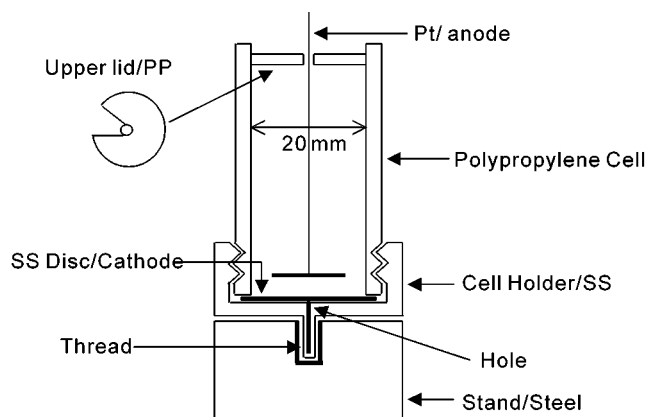

Figure 1. Schematic diagram of electrodeposition device.

products of the North America Scientific Inc. (North Hollywood, CA, USA). Each working solution of ^{241}Am and ^{244}Cm prepared by dilution of the stock solutions was about 20 Bq/mL. Standard planchet source of mixed nuclides (3.28×10^5 dps, Amersham Co. UK), which is composed of ^{239}Pu , ^{241}Am and ^{244}Cm in nearly the same ratio in activity, was used to measure counting efficiency and energy calibration of the alpha-counting instruments. Alpha-activities of the standard solution and standard planchet source were also corrected for the half life of the ^{244}Cm ($T_{1/2}$: 18.1y) to measure counting efficiency.

Sample pretreatment and alpha-spectrometry. A mixed solution of 0.03 M DTPA-0.3 M lactic acid was prepared for the sample pretreatment by mixed acid digestions⁵ because this matrix is the very chelating agents that was used for the separation of Am and Cm from uranium solution. 600 μL of 1.0 M NaHSO_4 and 400 μL 98% of H_2SO_4 were added to the small amount of the sample solution, and then it was heated on the hot plate to decompose the organic compounds until brown residue was obtained. 1-3 mL of 65% HNO_3 and 100-300 μL of 60% HClO_4 were added to the beaker depending on the amount of organic compounds in samples after the beaker cooled. The sample solution was heated again to get rid of black carbon component. This residue contained 0.4 mmole NaHSO_4 and 0.1 mmole Na_2SO_4 . Finally, 10 mL of 0.1 M NaHSO_4 -0.53 M Na_2SO_4 solution was obtained by dissolving the residue with 4.2 mL of H_2O and adding additionally 600 μL of 1.0 M NaHSO_4 and 5.2 mL of 1.0 M Na_2SO_4 . In case of a single nuclide, only gross-alpha counting was used for the determination of ^{241}Am or ^{244}Cm . In case of mixed nuclides, first, total activity was measured by gross-alpha counting and then the activity ratio of ^{241}Am over ^{244}Cm was obtained by alpha-spectrometry, which measured alpha-activity of each nuclide at the energy of 5.48 Mev for ^{241}Am and 5.81 Mev for ^{244}Cm , respectively. Finally, the activity of each nuclide was calculated from the total activity and the activity ratio measured above. The activity of each nuclide was converted to the weight using the specific activity of each nuclide. The alpha-energy calibration and measurement of counting efficiency of the instrument were performed using a standard planchet source, including ^{241}Am , ^{244}Cm and ^{239}Pu .

Results and Discussion

A group separation of Am and Cm together from other actinides, such as Pu and Np etc., is recommended because of the difficulty of individually separating these elements. Thus, the amounts of ^{241}Am and ^{244}Cm were determined by alpha-spectrometry after group separation. An electrodeposition device was made as shown in Fig. 1. A platinum anode was designed to have a spiral shape at the bottom part of the electrode to increase the surface area confronting the cathode, a planchet. The surface area of the planchet and current density were 314 mm^2 and 0.38 A/cm^2 , respectively. The distance between anode and cathode was about one cm. These data are similar to those of other investigators.^{1,3} The

electrolyte of 0.1 M NaHSO_4 -0.53 M Na_2SO_4 used in this study was already applied for the electrodeposition of plutonium.⁵ In this study, 10 mL of 0.1 M NaHSO_4 -0.53 M Na_2SO_4 buffer solution adjusted to pH 1.85 was used for the electrodeposition of ^{241}Am and ^{244}Cm as an electrolyte solution. Applied current, deposition time and concentration of DTPA were varied to examine the effect of electrodeposition yields. At the end of electrodeposition, one mL of 25% ammonia solution was added to the cell to make the solution alkaline, and then deposition was continued for one minute more. Sodium hydrogen sulfate used in this study is also known to be a complexing agent to prevent actinide elements from being hydrolyzed and to get rid of interfering elements of electrodeposition during dryness of the solution on the hot plate at the sample pretreatment process.⁵ Figure 2 shows the electrodeposition yield of ^{241}Am as a function of current intensity for an hour of electrodeposition time. As shown in Figure 2 the deposition yield of ^{241}Am increased until 1200 mA (~92%) and then decreased at higher current densities. This phenomenon presumes that high current density caused volume reduction by overheating and the

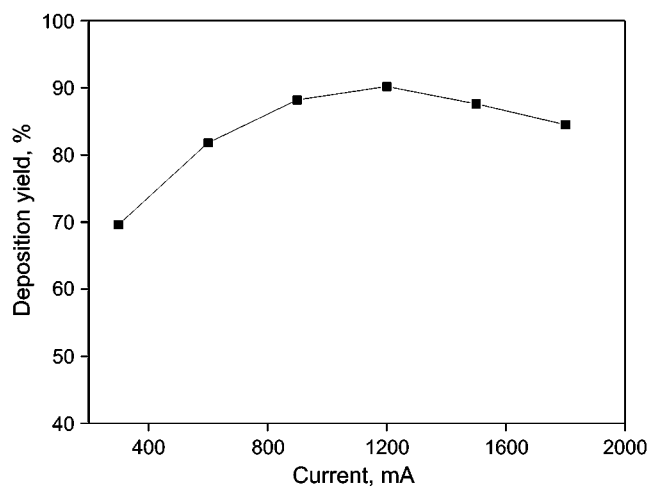

Figure 2. Electrodeposition yields of ^{241}Am as a function of current: ^{241}Am 8.34 Bq, 10 mL of 0.1 M NaHSO_4 -0.53 M Na_2SO_4 , 1 hr, 300 mA-1800 mA.

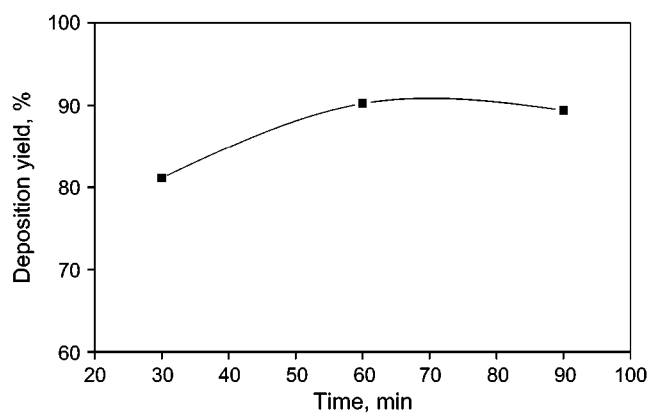

Figure 3. Electrodeposition yields of ^{241}Am as a function of time: ^{241}Am 8.34 Bq, 10 mL of 0.1 M NaHSO_4 -0.53 M Na_2SO_4 , 1200 mA, 30 min-90 min.

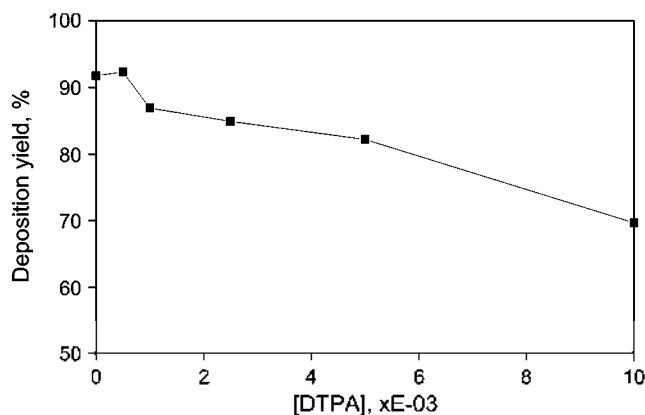

Figure 4. Electrodeposition yields of ^{241}Am as a function of DTPA concentrations: ^{241}Am 8.34 Bq, 10 mL of 0.1 M NaHSO_4 -0.53 M Na_2SO_4 , 10 mL, 1 hr, 1200 mA, DTPA: 0.0005 M-0.01 M.

reduced volume changed both the pH and the concentration of electrolyte, which decreased the electrodeposition yield. Over 1500 mA current density, volume was significantly reduced during the electrodeposition. Figure 3 shows the deposition yields of ^{241}Am as a variation of deposition time at a fixed current of 1200 mA. The deposition yield showed a plateau beyond one hour. Accordingly, the optimum conditions for the electrodeposition of ^{241}Am were found to be one hour and 1200 mA in 0.1 M NaHSO_4 -0.53 M Na_2SO_4 solution. This condition also agreed with that of plutonium⁵. The electrodeposition of ^{244}Cm in this study was performed in the same condition as that of ^{241}Am without any further test to find optimum conditions. The concentration of DTPA was examined to see the effect of deposition yield on ^{241}Am as shown in Figure 4. On the whole, the deposition yield decreased with increasing DTPA concentration except for a very low concentration of DTPA, 5×10^{-4} M. This phenomenon means that the stability constant between Am and DTPA is very high.^{7,8} The reason for the increase of deposition yield at a very low concentration of DTPA, 5×10^{-4} M, was not identified. However, it was reported that DTPA enhanced the deposition yield of plutonium up to 5×10^{-3} M because of the prevention of polymerization of plutonium and caused a decrease beyond this concentration due to the high stability constant at a high concentration of DTPA.³ In this study, the electrodeposition of ^{241}Am and ^{244}Cm in spent nuclear fuel sample solutions was carried out in 0.1 M NaHSO_4 -0.53 M Na_2SO_4 solution without DTPA because DTPA did not give any considerable advantage for deposition yields even at very low concentrations of DTPA, 5×10^{-3} M. The voltage was dropped from 9.2 V to 6.8 V during the deposition of ^{241}Am . This result was also similar to that of another study⁵ in which the voltage was dropped from 9.2 V to 5.7 V. In the sample matrix containing 0.03 M DTPA and 0.3 M lactic acid, sample pretreatment was performed as mentioned before. The amounts of sodium hydrogen sulfate and sulfuric acid used for sample pretreatment should be controlled to give the final concentrations of 0.1 M NaHSO_4 and 0.53 M Na_2SO_4 in case of samples containing organic compounds. Finally, ^{241}Am and ^{244}Cm

Table 1. Electrodeposition yields of ^{241}Am and ^{244}Cm at various sample conditions

element sample	^{241}Am			^{244}Cm		
	added (Bq)	found (Bq)	yield (%) + 1S	added (Bq)	found (Bq)	yield (%) + 1S
sample 1	8.34	7.52	90.2	13.66	13.28	97.2
sample 2	8.34	7.88	95.5	13.66	13.37	97.9
sample 3	8.34	7.47	89.6	13.66	13.55	99.2
sample 4	8.34	7.65	91.7	—	—	—
aver.			91.8 ± 2.7			98.1 ± 1.0
sample 5	12.51	11.5	91.9	8.24	8.29	100.6
sample 6	12.51	11.27	90.1	8.24	8.15	98.9
sample 7	12.51	11.1	88.7	8.24	8.26	100.2
sample 8	12.51	11.01	88.0	8.24	8.05	97.7
aver.			89.7 ± 1.7			99.4 ± 1.3
sample 9	12.51	11.95	95.5	8.24	8.15	98.9
sample 10	12.51	11.57	92.5	8.24	8.29	100.6
sample 11	12.51	11.59	92.6	8.24	8.3	100.8
aver.			93.5 ± 1.7			100.1 ± 1.0
total			91.5 ± 2.5			99.2 ± 1.3

*sample 1-4: 0.1 M NaHSO_4 -0.53 M Na_2SO_4 ; single nuclide deposited. sample 5-8: 0.03 M DTPA-0.3 M lactic acid; sample pretreatment; single nuclide deposited. sample 9-11: 0.03 M DTPA-0.3 M lactic acid; sample pretreatment; two nuclides deposited.

were electrodeposited in 0.1 M NaHSO_4 -0.53 M Na_2SO_4 matrix, which resulted from sample pretreatment and was determined by alpha-spectrometry. Table 1 shows the electrodeposition yields of ^{241}Am and ^{244}Cm at various conditions of matrix and nuclides. As shown in Table 1, the nearly same deposition yields were obtained within acceptable precisions at the various conditions, such as at the matrix of 0.1 M NaHSO_4 -0.53 M Na_2SO_4 with or without sample pretreatment in a single nuclide of ^{241}Am or ^{244}Cm , and with sample pretreatment in both nuclides. The deposition yields of ^{241}Am and ^{244}Cm determined in this work were $91.5 \pm 2.5\%$ and $99.2 \pm 1.3\%$, respectively. The good precision in

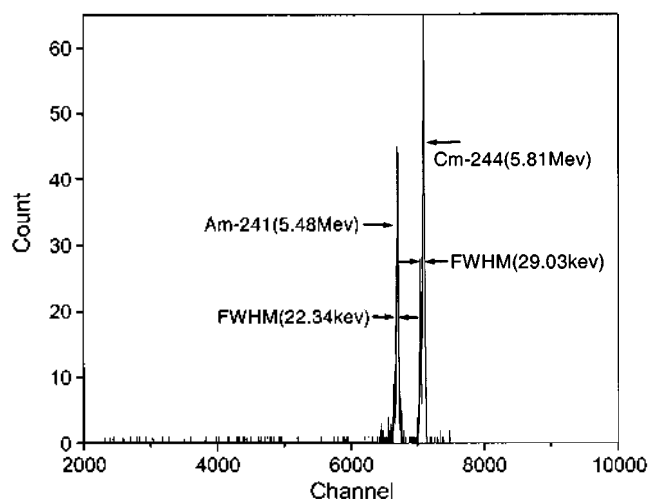

Figure 5. Alpha-spectrum of ^{241}Am and ^{244}Cm in the spent nuclear fuel sample after electrodeposition: sample no: SF-9, ^{241}Am 6.5 Bq, ^{244}Cm 8.8 Bq, counting time: 5000 sec.

Table 2. Amounts of ^{241}Am and ^{244}Cm in spent nuclear fuel sample solutions determined by electrodeposition followed by alpha-spectrometry

sample		SF-4	
nuclide	^{241}Am ($\mu\text{g}/\text{mgU}$)	^{244}Cm ($\mu\text{g}/\text{mgU}$)	
measurement	0.6838, 0.6629, 0.6396	0.0262, 0.0230, 0.0238	
aver. (x) \pm 1S (%)	$0.6621 \pm 3.34\%$	$0.02437 \pm 6.76\%$	
ORIGEN-2 (c)	0.6439	0.0244	
diff. (x-c/c)	2.83%	-0.12%	
sample		SF-9	
nuclide	^{241}Am ($\mu\text{g}/\text{mgU}$)	^{244}Cm ($\mu\text{g}/\text{mgU}$)	
measurement	0.7298, 0.7437, 0.7327	0.0369, 0.0361, 0.0378	
aver. (x) \pm 1S (%)	$0.7354 \pm 0.99\%$	$0.0369 \pm 2.44\%$	
ORIGEN-2 (c)	0.6923	0.0354	
diff. (x-c/c)	6.22%	4.32%	

these data also means that high reproducibility associated with the analytical procedures, such as sample pretreatment, electrodeposition, gross alpha-counting and alpha-spectrometry etc., was obtained. The alpha-activity of individual nuclide was determined⁹ by the procedure mentioned in the experiment section. A total of six measurements were conducted for two spent nuclear fuel sample solutions and three measurements for each sample solution. The procedure, such as sample pretreatment, electrodeposition and alpha-spectrometry was the same as that of the recovery test done previously. In Figure 5 the alpha-spectrum of ^{241}Am and ^{244}Cm in the spent nuclear fuel sample is shown. The peak resolutions of the two nuclides by alpha-spectrometry were the range of 20-30 keV as a FWHM over all the synthetic solutions and spent fuel samples. These peak resolutions were also similar to those of standard sources. As shown in Table 2 a good agreement between experiment and calculation¹⁰ (ORIGEN-2) was obtained for the two nuclides in both samples. The difference between measurement and calculation was within 6% for ^{241}Am and within 4% for ^{244}Cm in spent nuclear fuel samples. The precisions (1S)

among measurements in each sample were also in the range of 3% for ^{241}Am and 7% for ^{244}Cm in these samples.

Conclusion

Electrodeposition was applied to the determination of ^{241}Am and ^{244}Cm in spent nuclear fuel samples with a high reliability after optimum deposition conditions were obtained. In the future the application of this method will be expanded to other actinide elements, including Np and Pu etc. and also the analytical quality of this method will be improved by cross-checking with other methods, such as mass spectrometry etc.

Acknowledgements. This study was performed as part of the Long- and Mid-term Nuclear R&D Programs funded from the Ministry of Science and Technology of Korea. The authors are grateful to Dr. Kwang-Yong Jee and Dr. In-Kyu Choi of KAERI for their comments.

References

- Puphal, K. W.; Olsen, D. R. *Anal. Chem.* **1972**, *44*(2), 284-289.
- Glover, S. E.; R. H. Filby; R. II.; Clark, S. B.; Crytdal, S. P. *J. Radioanal. Nucl. Ch.* **1998**, *234*(1), 213-218.
- Lee, M. H.; Lee, C. W. *Nucl. Instrum. Meth. A* **2000**, *447*, 593-600.
- Ingelbrecht, C.; Moens, A.; Eykens, R.; Dean, A. *Nucl. Instrum. Meth. A* **1997**, *397*, 34-38.
- Bajo, S.; Eikenberg, J. *J. Radioanal. Nucl. Ch.* **1999**, *242*(3), 745-751.
- Talvitie, N. A. *Anal. Chem.* **1972**, *44*(2), 280-283.
- Martell, A. E. *Stability Constants of Metal-Ion Complexes, Part II Organic Ligands Including Macromolecule Ligands*; The Chemical Society; Alden Press: Oxford, U. K., 1971; pp 728-729.
- Perrin, D. D. *Stability Constants of Metal-Ion Complexes, Part B Organic Ligands*; Pergamon Press: Oxford, UK, 1979; p 996-997.
- Lawrence Livermore National Laboratory. *FS&H Manual, Document 20.2: LLNL Radiological Safety Program for Radioactive Materials*, 1999; p 64-65.
- Croff, A. G. *ORNL-5621, ORIGEN-2: A Revised and Updated Version of Oak Ridge Isotope Generation and Depletion Code*, 1980.