

A Study on the Mixture Formation Process of Evaporating Diesel Spray by Offset Incidence Laser Beam

Jeong-Kuk Yeom*

Department of Automotive Engineering, Silla University, Pusan 617-736, Korea

Byung-Mu Kang

Graduate school of Dong-A University, Pusan, 604-714, Korea

Myung-Jun Lee

Automotive Engineering Department, Yang-san College., Kyungnam 449-728, Korea

Sung-Sik Chung, Jong-Yul Ha

Mechanical Engineering Department, Dong-A University, Pusan 604-714, Korea

Hajime Fujimoto

Department of Mechanical Engineering, Doshisha University, Kyotanabe, Kyoto, Japan

This paper analyzes heterogeneous distribution of branch-like structure at the downstream region of the spray. The liquid and vapor phase of the spray are obtained using a 35mm still camera and CCD camera in order to investigate spray structure of evaporating diesel spray. There have been many studies conducted on diesel spray structure but have yet only focused on the analyses of 2-D structure. There are a few information which is concerned with 3-D structure analysis of evaporating spray. The heterogeneous distribution of droplets in inner spray affects the mixture formation of diesel spray and the combustion characteristics of the diesel engines. In this study, the laser beam of 2-D plane was used in order to investigate 3-D structure of evaporating spray. The incident laser beam was offset on the central axis of the spray. From the analysis of images taken by offset laser beam, we will examine the formation mechanism of heterogeneous distribution of the diesel spray by vortex flow at the downstream of the spray. The images of liquid and vapor phase of free spray are simultaneously taken through an exciplex fluorescence method. Through this, the branch-like structure consisting of heterogeneous distribution of the droplets forms high concentrated vapor phase at the periphery of droplets and at the spray tip.

Key Words : Diesel Spray, Heterogeneous Distribution, Offset, Vortex, Laser-Induced Fluorescence Technique

1. Introduction

In diesel engines, the injected fuel is developed with atomization, evaporation, diffusion and mixture formation by interactions between the fuel

and ambient gas. In order to reduce the emissions from diesel engines, for example PM (particulate matter) including soot and NO_x (nitrogen oxides), it is very important to study the mixture formation process of the diesel spray. Therefore, the focus of this study is to clearly make the process of mixture formation by undertaking structure analysis of the diesel spray in an evaporating field under high temperature and pressure. Also, the injected fuel takes the surface wave at upstream spray caused by the interaction between

* Corresponding Author,

E-mail : yeomjk@yahoo.co.kr

TEL : +82-51-200-6714; FAX : +82-51-200-7656

Department of Automotive Engineering, Silla University, Pusan 617-736, Korea. (Manuscript Received November 17, 2001; Revised October 11, 2002)

injected fuel and ambient gas, and the wave becomes the core of the vortex flow in diesel spray (Levich, 1974). The initial protrusion is called the first perturbation. With the development of the spray, the first perturbation grows toward to the downstream of the spray (Azetsu et al., 1990). As a result, the flow of the ambient gas with interchanged momentum from injected fuel dominates spray behavior at the downstream.

On the other hand, as the droplets of injected fuel are dependent on the spray flow according to the droplet size, heterogeneous distribution of droplets in inner spray occurs. The dispersed droplets evaporate and the evaporated vapor also then forms the mixture by the entrainment of ambient gas. Therefore, the structure analysis of the liquid and vapor phase is very important. However, only a few studies about mixture formation process through the analysis of the each liquid and vapor phase structure of injected spray under high temperature and pressure field have been done. Dan et al., 1996 studied non-evaporating fuel spray regardless of the phase change of actual diesel spray, Siebers (1998, 1999) had conducted studies on liquid phase length in evaporating field, and Kosaka et al., (1992) had dealt with the vapor phase distribution in connection with the change in injection pressure at high temperature and pressure. However, they did not consider the effect of liquid phase on the formation of vapor phase. Therefore, here we study mixture formation process of a diesel spray from the spray structure of liquid and vapor phase, respectively. Furthermore, in this study, the 3-D analysis is tried by the offset of incident laser beam from central axis of the spray based on the 2-D analysis results of spray structure.

2. Experimental Apparatus and Procedure

Figure 1 is a schematic diagram of experimental apparatus. The constant volume vessel has two quartz glass windows ($\Phi=120\text{ mm}\times 45\text{ mm}$ width) permitting the spray inside to be irradiated with a sheet of laser light and allowing the fluorescence emissions from the spray to be

Table 1 Experimental conditions

Injection nozzle	Type : Hole nozzle DLL-p	
	Diameter of hole d_n [mm]	0.2
	Length of hole L_n [mm]	1.0
Ambient gas		N ₂ gas
Ambient temperature	T_a [K]	700
Ambient pressure	p_a [MPa]	2.55
Ambient Density	ρ_a [kg/m ³]	12.3
Injection pressure	p_{inj} [MPa]	72
Injection quantity	Q_{inj} [mg]	12.0
Injection duration	t_{inj} [ms]	1.54

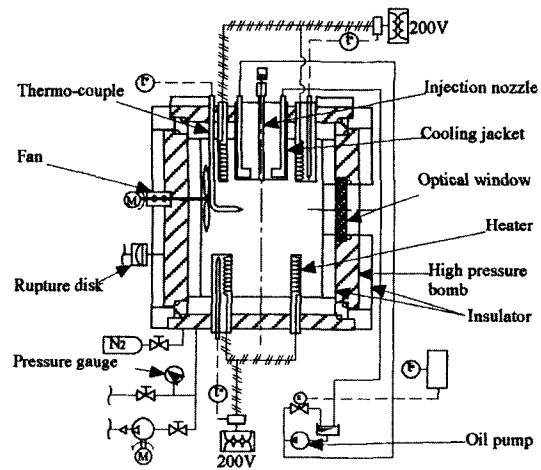

Fig. 1 Experimental apparatus

measured. Each of the windows was perpendicularly installed. The n-tridecane, as the reference fuel oil of JIS second class gas oil, was injected into the quiescent atmosphere of nitrogen gas through an injector with single hole. 9% in mass of naphthalene and 1% in that of TMPD (N, N, N', N' tetramethyl-p-phenylene diamine) were mixed in n-tridecane to obtain the fluorescent emissions of vapor and liquid phases. The high pressure injection system (ECD-U2 system) was proposed by Denso Co., Ltd.. This system consists of three main sections, namely, high pressure supply pump, common rail and control circuit (ECU), which controls the injector. Table 1 shows the experimental conditions of this study.

Figure 2 shows the measurement range and offset of laser beam in this study.

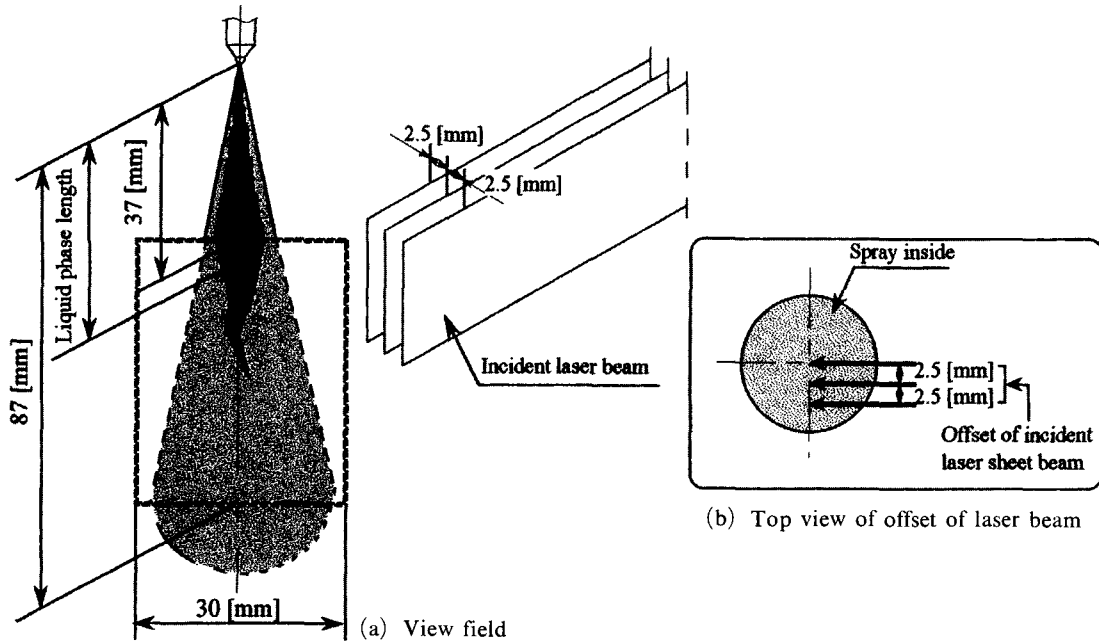

Fig. 2 Schematic of visual region and offset of laser beam

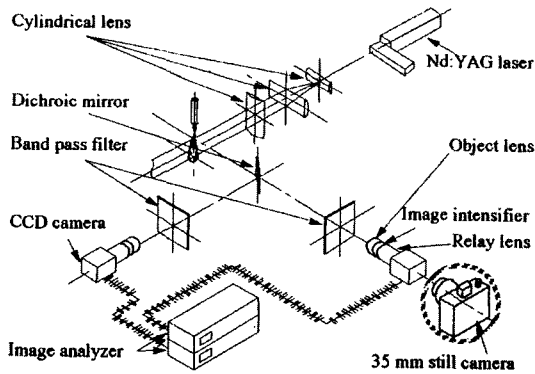

Fig. 3 Schematic diagram of laser sheet optical system and photography system

Figure 3 is a schematic of the optical system used in this study. The light source was the third harmonic of an Nd:YAG laser at 355 nm (power 60 mJ/pulse, pulse width: 8 nsec., maximum frequency: 10 Hz, beam diameter: 6.4 mm, beam shape: doughnut type). A thin sheet of laser light was formed when the light was passing through the three sets of cylindrical lenses that were made of quartz. The width and the thickness of the light were 50 mm and 0.2 mm, respectively. Then, a thin sheet of laser light came in through the section of a free diesel spray and the fluorescence

emissions from both vapor and liquid phase were generated. The separation of spectra of fluorescence emissions from both phases was made by the system of a dichroic mirror and two sets of band pass filters. The dichroic mirror used was a type of blue reflection and its wavelength of 50% reflection was 470 nm. The center wavelength of the band pass filter for vapor and liquid phases widths were 390 nm and 532 nm and their half widths were 19 nm and 2 nm, respectively. The emissions from both phases were increased in their luminosity by the image intensifiers after they came in through the objective lenses. Thereafter, while they enter into the relay lenses, the images are taken by the CCD cameras (number of pixels: 540×480 , S/N: 50dB). The photographing speed of the CCD camera was $1/30 \mu\text{sec.}$, and the life time of fluorescent emissions of TMPD and exciplex ranged from 1nsec. to 10^3 nsec.. This experiment was carried out in a perfectly enclosed photo darkroom. Consequently, the frozen image at the incidence of the laser light could be caught by this CCD camera. The spatial resolution was about 0.1 mm/pixel. The signals from images of both phases were transferred into an image analyzer and were processed by an

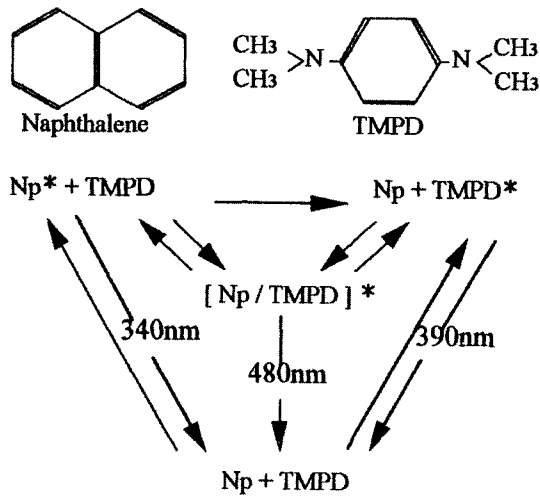

Fig. 4 Schematic summary of naphthalene and TMPD exciplex system

A/D conversion (resolution : 8bits) to obtain the image of 256 gradation.

In Fig. 4 (Melton, 1983), a schematic summary of the photophysics of the naphthalene/TMPD exciplex fluorescence system is shown.

3. Results and Discussion

3.1 The analysis of liquid and vapor phase structure in evaporating diesel spray using exciplex fluorescence method

Figures 5(a), (b), and (c) show the two-dimensional images of free spray by exciplex fluorescence method. The time in Fig. 5 denotes the time after the injection start. For the image-taking of liquid phase fuel, 35 mm still camera was used using high quality film (Fuji photo film : micro film negative HR11). Also, in the figure, (i) and (ii) are vapor and liquid phase of injected fuel, and the horizontal axis is the radial distance from nozzle axis and the vertical axis is the distance from nozzle tip, respectively. In every image, the fluorescence signal appears high intensity due to the overlap both the liquid and vapor phase at the region of the central spray axis. Hence, in vicinity of spray center, fluorescence intensity exceeds the sensitivity of CCD camera. In Fig. 5(a), ($t=1.12$ ms), vapor phase of high fluorescence intensity appears around liquid phase, however,

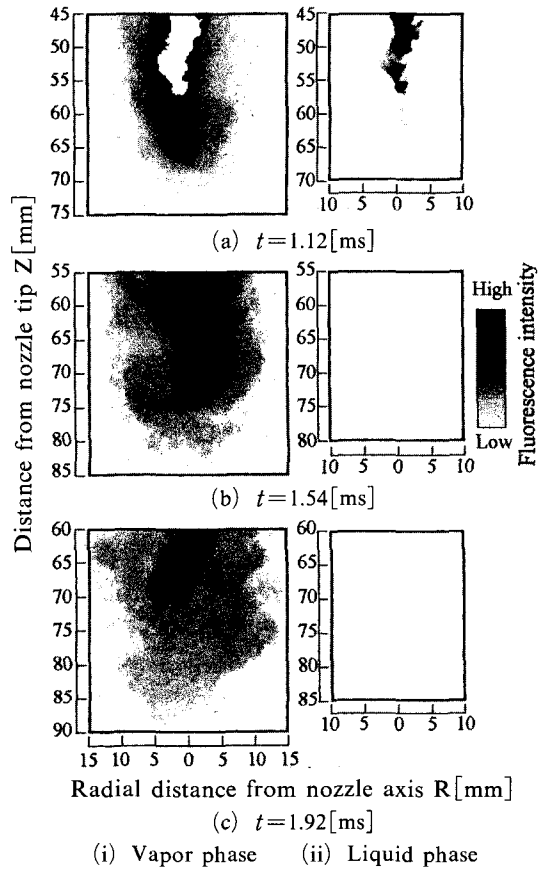

Fig. 5 Spray images taken by exciplex fluorescence method ($p_{inj}=72$ [MPa], $Q_{inj}=12.0$ [mg], $\rho_a=12.3$ [kg/m³], $T_a=700$ [K])

in Fig. 5(b) and (c), ($t=1.54, 1.92$ ms), it can be observed that the regions of vapor phase becomes larger while region of liquid phase disappears. The high fluorescence region of vapor phase is seen to decrease due to the homogenization of the mixture by the entrainment of ambient gas. Also, from analysis of images of liquid and vapor phase, it can be confirmed that there is meandering flow of liquid phase by large-like vortex at Fig. 5(a) of $t=1.12$ ms. However, in this study, the branch-like structure can not be clearly observed, as non-evaporating fuel spray (Dan et al., 1996), and the region like the diffused misty structure spreads outside spray region. Then, the overlapping of small droplets fluorescence occurs in the outside region of the spray. Also, there are larger droplets at the region of spray tip. As a

result, the high fluorescence intensity of vapor phase is distributed as the two-regions of larger droplets and atomized small droplets, because there is highly concentrated vapor phase in the vicinity of the droplets. On the other hand, there is no liquid phase in Fig. 5(b), ($t=1.54$ ms), because the evaporation of droplets was completed. In Fig. 5(c), there is no high fluorescence region of vapor phase in the image. As, it can be speculated that the distribution of droplets in inner spray is closely related with the structure of vapor phase formation of evaporating spray, and high concentration of vapor phase is formed around outside region of liquid phase.

Figures 6 and 7 show the temporal change in

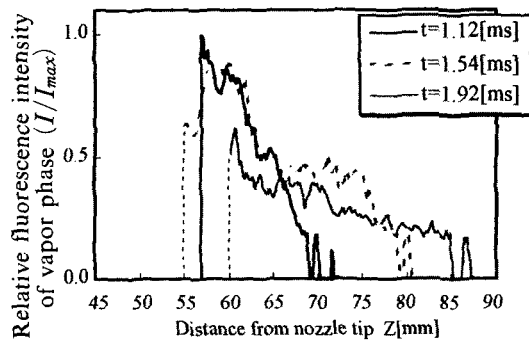

Fig. 6 Axial distribution of fuel vapor fluorescence intensity on spray axis

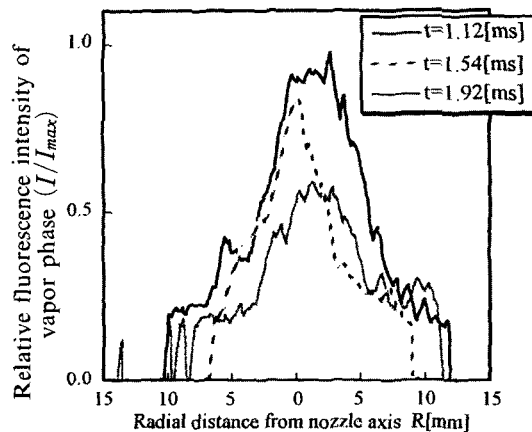

Fig. 7 Radial distribution of fuel vapor fluorescence intensity at $Z=60$ [mm]

vapor phase fluorescence at the central axis and radial direction of the spray. The horizontal axes are radial distance from nozzle axis and distance from nozzle tip, respectively. Each vertical axis shows non-dimensional intensity to maximum intensity (255). From the results of Figs. 6 and 7, the saturation phenomenon in vapor region due to the overlapping liquid phase of evaporating spray at $t=1.12$ ms at the central spray axis. However, with the development of spray toward to the downstream of the spray, the saturated region turns to vapor region of the high fluorescence intensity, as shown in Fig. 5(b) of $t=1.54$ ms. The high fluorescence region in vapor phase image of $t=1.54$ ms disappears at the $t=1.92$ ms because of diffusing vapor phase of low fluorescence intensity out spray whole. Therefore, the liquid phase of inner spray evaporates rapidly at the same time as the injection end and the formed vapor phase diffuses. As a result, from the results of Figs. 5, 6, and 7, it can be assumed that the vapor phase distribution of high concentration formed is dependent on the flow of droplets at the outside and tip region of the liquid phase, also, the heterogeneous distribution of vapor phase is identified due to the meandering flow of liquid phase by vortex flow in evaporating spray.

3.2 The approach of 3-D structure analysis for diesel spray using the offset of incident laser beam

Figure 8 shows exciplex fluorescence images which were taken by 2.5 and 5.0 mm offset of incident laser beam from central axis of the spray at $t=1.54$ ms. As shown in Fig. 8(b), in the case of 2.5 mm offset from the central axis of the spray, and the images are clearly different from those of central spray, particularly, in the region of the vapor phase. In other words, in the 2.5 mm offset case of incident laser beam, the images are not continuous image at the high fluorescence intensity region of the vapor phase but discontinuous-image by heterogeneous distribution in the spray. Also, there is the vortex branch-like structure (Dan et al., 1996) which implies distribution of the heterogeneous droplets caused by interaction between the injected fuel and ambient gas in

inner spray. As a result, it can be speculated that the development process of actual diesel spray has spatiotemporally complex profile of 3-D structure in inner spray. The figure 8(c) shows images taken using a 5.0 mm offset of the incident laser beam. As shown in the figure, no droplets of spray in 5.0 mm offset are seen due to the spatial heterogeneous distribution of fuel droplets. This result implies that in the case of offset of 5.0 mm from the central spray axis, the laser beam passes the plane on which no distribution of

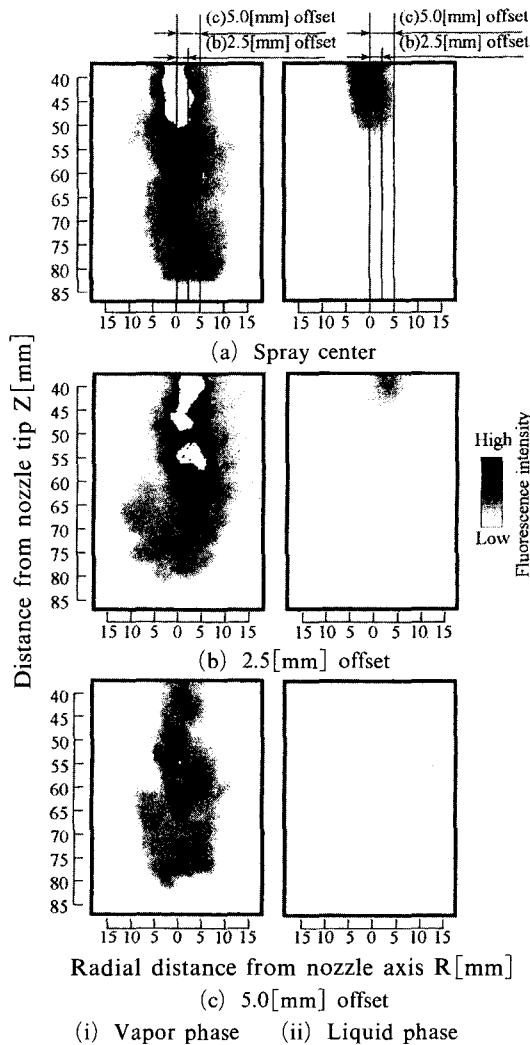

Fig. 8 Images of spray taken by exciplex fluorescence method at $t=1.54$ [ms] ($p_{inj}=72$ [MPa], $Q_{inj}=12.0$ [mg], $\rho_a=12.3$ [kg/m³], $T_a=700$ [K])

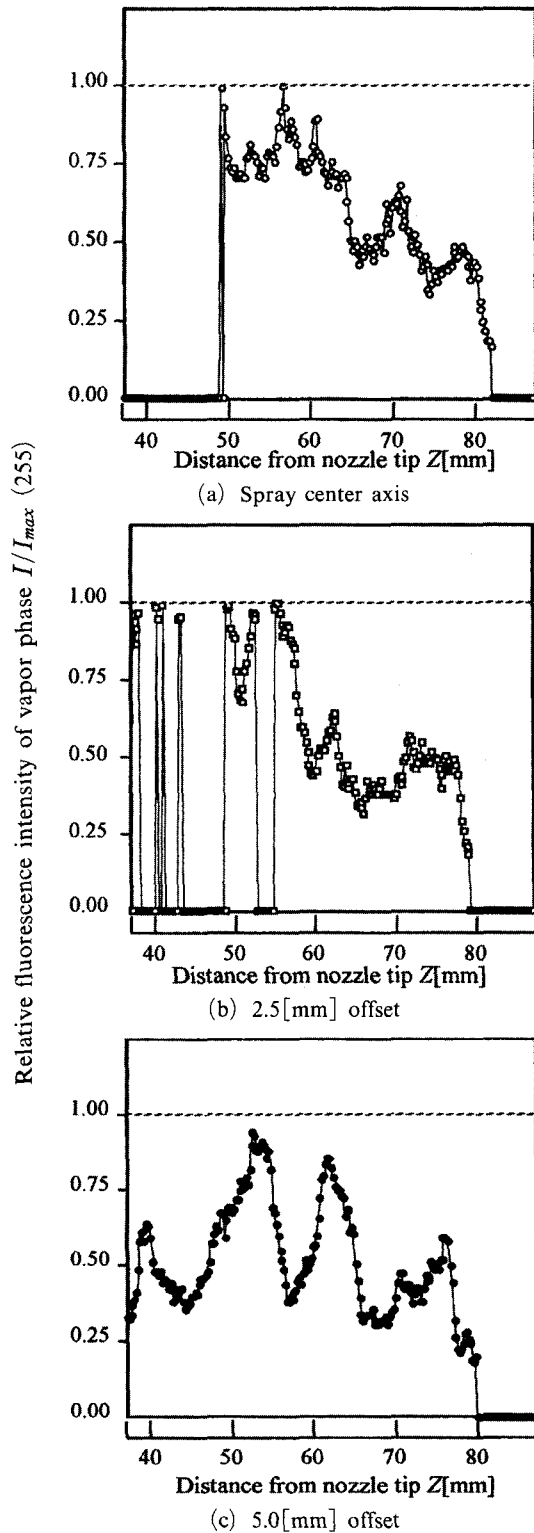

Fig. 9 Relative fluorescence intensity of vapor phase at axial direction of the spray

droplets exists. Hence, it is revealed that the diesel spray has 3-D structure and the initial perturbation of diesel spray forms at the upstream of the spray by interaction (shear force) between injected fuel and ambient gas, while the perturbation is developing toward the downstream of the spray. Finally, the evaporating diesel spray has heterogeneous distribution of the droplets and distribution of heterogeneous concentration similar to branch-like structure as a result of the effect of interaction between the fuel and ambient gas.

Figure 9 shows relative fluorescence intensity of vapor phase in radial direction. In Fig. 9(a), saturation phenomenon occurs due to overlapping of both liquid and vapor phase in the region of $Z \leq 50$ mm, and intensity of fluorescence gradually decreases in the region of $50 \text{ mm} \leq Z$. In the upper region of $Z \leq 55$ mm in Fig. 9(b), relative fluorescence intensity dramatically changes due to

region of saturation, however, change tendency of fluorescence intensity is similar to that of Fig. 9 (a) in the region of $55 \text{ mm} \leq Z$ approximately. There is no discontinuous region of relative fluorescence intensity in the case of offset 5.0 mm of the Fig. 9(c), and the concentration distribution of vapor phase varies with the axial distances. As a result, it is speculated that the spatial distribution of spray's droplets affects concentration distribution of vapor phase in inner spray of axial direction.

Figure 10 shows the change in the relative fluorescence intensity of vapor phase in the case of 2.5 mm offset at the central spray axis. The relative fluorescence intensity of each figure is normalized by maximum fluorescence intensity of position A. These distances (45 mm, 50 mm, 55 mm, 60 mm, 65 mm) were determined by liquid length (40 mm) defined in the result of Yeom et

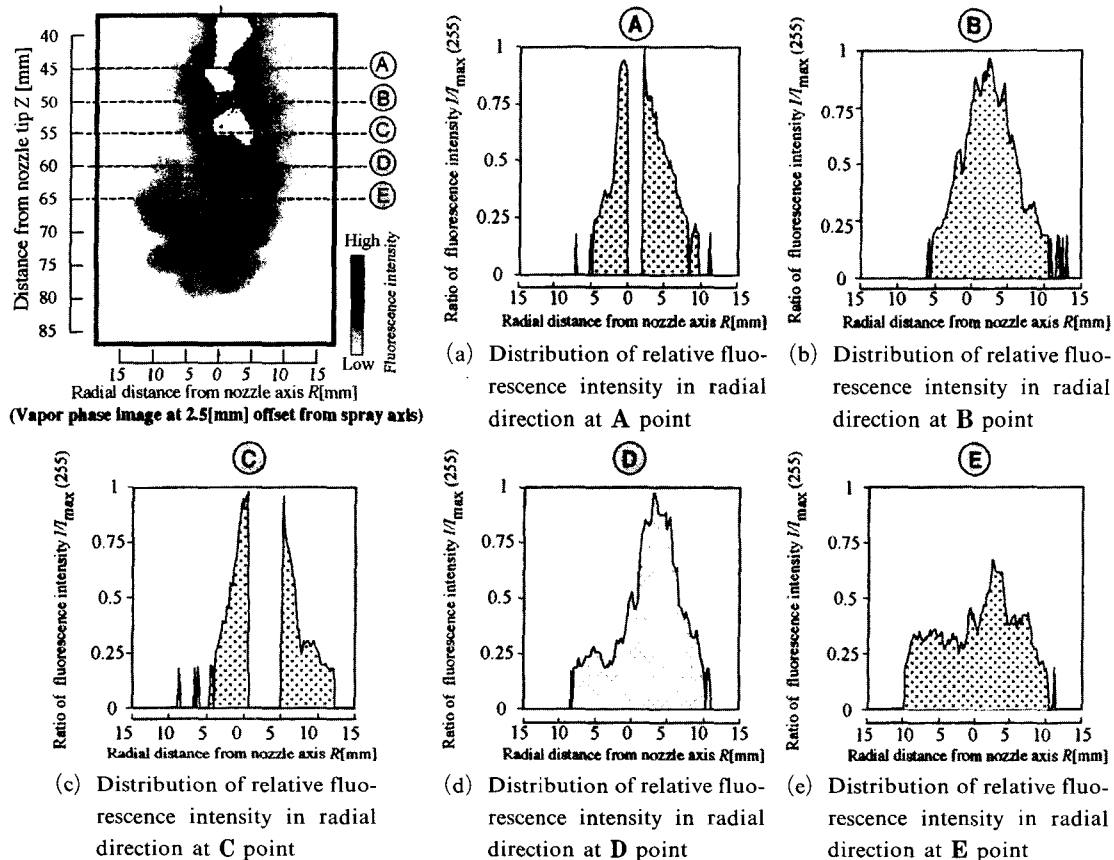

Fig. 10 Temporal change in fluorescence intensity at radial direction for each distance from nozzle tip

al., 2001. The fluorescence intensity is distributed as profile of symmetry. On the other hand, there is no discontinuous region of fluorescence intensity by saturated region in Fig. 10(b), and the distribution of fluorescence intensity is asymmetry. In Fig. 10(c), the saturated region is observed again, however, the distribution of fluorescence intensity is found to be asymmetry, as in Fig. 10(b). In the cases of Fig. 10(d) and (e), radial spread of vapor phase increases due to the resistance of ambient gas at the portion of the spray tip. The maximum value of fluorescence intensity is located far from the axial center, and the distribution curve of the fluorescence intensity is asymmetrical in shape. Such results of experiment signify meandering structure of vapor phase like non-evaporating spray (Azetsu et al., 1990). The structure of evaporating spray based on the results of this study that was conducted in unsteady and evaporative field can divide into three regions. The first region called the liquid length is the region of momentum exchange from the liquid jet to the ambient gas. The entrainment of ambient gas into the inner spray actively occurs in the second region called the mixing region. There is the distribution of the heterogeneous droplets caused by interaction between the injected fuel and ambient gas in inner spray, particularly in the second region. Finally, the third region called the stagnation region is the region of gas jet flow, and the development of diesel spray is complete.

4. Conclusions

In this study, the structure of liquid and vapor phase in diesel spray was analyzed by using exciplex fluorescence method. Also, we examined the 3-D structure of evaporating diesel spray. The following conclusions were drawn from this study.

(1) The vapor phase of high concentration forms around droplets of branch-like structure and the region of spray tip, and such spray structure affects the process of mixture formation.

(2) The evaporating sprays have heterogen-

eous distribution of vapor phase due to branch-like structure consisting of droplets such as non-evaporating spray in inner spray.

(3) The concentration distribution of vapor phase decreases gradually while proceeding in the radial direction. Also, the distribution curve of the fluorescence intensity is asymmetrical in shape, and such structure of fluorescence intensity signifies meandering structure of evaporating spray.

(4) The 3-D structure of evaporating diesel spray can be identified by using offset incidence laser beam.

References

- Azetsu, A., Dodo, S., Someya, T. and Oikawa, C. 1990, "A Study on the Structure of Diesel Spray (2-D Visualization of the Non-Evaporating Spray)," *COMODIA 90*, pp. 199~204.
- Dan, T., Takagishi, S., Ohishi, K., Senda J. and Fujimoto, H. 1996, "Effect of Ambient Gas Viscosity on the Structure of Diesel Fuel Spray," *JSME (part2)*, Vol. 62, No. 95-1526, pp. 2867~2873, (in Japanese).
- Yeom J. K., Dan T., Ashida K., Senda J. and Fujimoto H., "Analysis of Diesel Spray Structure by Using a Hybrid Model of TAB Breakup Model and Vortex Method," *SAE paper*, 2001-01-1240.
- Kosaka, H., Won, Y. H. and Kamimoto, T., 1992, "A Study of the Structure of Diesel Sprays Using 2-D Imaging techniques," *SAE Paper*, No. 920107.
- Levich, V. G. 1974, *Physicochemical Hydrodynamics*. Prentice-Hall, pp. 639.
- Melton, L. A. 1983, *Spectrally Separated Fluorescence Emissions for Diesel Fuel Droplets and Vapor*, *Applied Optics*, Vol. 21, No. 14, pp. 2224~2226.
- Siebers, D. L., 1998, "Liquid-Phase Fuel Penetration in Diesel Sprays," "SAE paper, 980809.
- Siebers, D. L., 1999, "Scaling Liquid-Phase Fuel Penetration in Diesel Sprays Based on Mixing-Limited Vaporization," *SAE paper*, 99010528.