

NORAD TLE TYPE ORBIT DETERMINATION OF LEO SATELLITES USING GPS NAVIGATION SOLUTIONS

Chang-Hwa Cho¹, Byoung-Sun Lee^{2†}, Jeong-Sook Lee², Jae-Hoon Kim², and Kyu-Hong Choi¹

¹ Department of Astronomy and Space Science, Yonsei University, Seoul 120-749, Korea

² Communications Satellite Development Center, ETRI, Daejeon 305-350, Korea

E-mail: lbs@etri.re.kr

(Received August 13, 2002; Accepted August 27, 2002)

ABSTRACT

NORAD Two Line Elements (TLE) are widely used for the increasing number of small satellite mission operations and analysis. However, due to the irregular periodicity of generation of the NORAD TLE, a new TLE that is independent of NORAD is required. A TLE type Orbit Determination (TLEOD) has been developed for the generation of a new TLE. Thus, the TLEOD system can provide an Antenna Control Unit (ACU) with the orbit determination result in the type of a TLE, which provides a simple interface for the commercialized ACU system. For the TLEOD system, NORAD SGP4 was used to make a new orbit determination system. In addition, a least squares method was implemented for the TLEOD system with the GPS navigation solutions of the KOMPSAT-1. Considering both the Orbit Propagation (OP) difference and the tendency of B* value, the preferable span of the day in the observation data was selected to be 3 days. Through the OD with 3 days observation data, the OP difference was derived and compared with that of Mission Analysis and Planning (MAPS) for the KOMPSAT-1. It has the extent from 2 km after six days to 4 km after seven days. This is qualified enough for the efficiency of an ACU in image reception and processing center of the KOMPSAT-2.

1. INTRODUCTION

For the missions of increasing small satellites without complicated orbit determination system in ground tracking station, Jochim et al. (1996) developed an orbit determination system with GPS navigation solutions and NORAD SGP4. They developed the system that does not require the TLE released by NORAD through making the result of orbit determination in the format of TLE. To reduce the operational cost of ground-based tracking system, they used GPS navigation solutions from a spaceborne GPS receiver. In addition, to simplify the navigation function, they made use of a SGP4, an analytical method that calculates the equation of the satellite motion rapidly. As an estimation method, they applied Extended Kalman Filter (EKF).

After participating in the above research and working together, Montenbruck et al. (2000) in German Space Operations Center (GSOC), German Aerospace Research Establishment (DLR) designed and implemented an on-board navigation system for the German Bi-spectral InfraRed Detection (BIRD) microsatellite. The BIRD was equipped with GEM-S, a spaceborne GPS receiver

[†]corresponding author

from which GPS navigation solutions can be given. In this system, a real-time orbit determination algorithm for the direct estimation of mean SGP4 orbital parameters has been implemented.

Also, Montenbruck (2000) developed the previous algorithms into the Real Time SGP4 (RTSGP4) prototype software for ground based testing and filter tuning. An epoch state Kalman filter was implemented and tested with GPS flight data of GPS/MET and MOMSNAV (MIR). It was demonstrated that the proposed method provides an accuracy compatible with that of the analytical model and was robust enough to handle large data gaps in case of limited on-board resources for GPS operations. The method of the transformation between Earth Centered Earth Fixed (ECF) coordinate system and Mean Equinox and True Equator (METE) coordinate system was introduced in this research.

On the base of the above system methods, a TLEOD system has been developed. The result of the TLEOD is given to an Antenna Control Unit (ACU) in the type of a TLE. A least squares method is used for the estimation of the state variables. In the case of the KOMPSAT-1, GPS navigation solutions are obtained through a spaceborne GPS receiver. To select the span of the day in the observation data in the TLEOD system, several cases are tested. The results of a new TLE by the OD are compared with those of the NORAD TLE to show how accurate the orbit determination is. Then, the tendency of ballistic coefficient, the value having most random characteristics in the NORAD TLE, is compared. In both comparisons, the difference of errors according to the span of the day in observation data is also analyzed and the preferable span of an observation day is determined. Finally, the differences of the orbit propagation between an analytical method with a new TLE and a numerical method are compared. In case of the KOMPSAT-1, Mission Analysis and Planning Subsystem (MAPS) is used as a numerical method (Lee et al. 2001).

2. CONCEPT OF THE TLEOD SYSTEM

The TLEOD system determines the orbit of the satellites in the type of a TLE using GPS navigation solutions as observation data, the NORAD TLE as an initial value, and NORAD SGP4 as an orbit propagator of the satellites. As mentioned in the research of Montenbruck et al. (2000), the choice of SGP4 is based on its widespread application for near-circular, low-altitude satellites and its high communality with existing ground equipment and Commercial Off-The-Shelf Software (COTS) products.

A new TLE by the TLEOD is independent of the NORAD TLE. The NORAD TLE is released arbitrarily. In most case, its releasing period is almost one week while the NORAD TLE in the case of the KOMPSAT-1 is given somewhat regularly through the contract with NASA. However, GPS navigation solutions can be provided at an interval of 32 seconds with a spaceborne GPS receiver and the usage of those determines a new orbit with the least squares method. As a result, the updated TLE with a regular time interval can be acquired.

The process from GPS navigation solutions to its application is shown in Figure 1. The signals from GPS satellites go to a spaceborne GPS receiver. Then the GPS receiver generates the navigation solutions. The GPS navigation solutions are sent to the mission control center. The ACU is used for pointing of the ground antenna to the satellite. After the process of the orbit determination, a new TLE is obtained and can be used for the following orbit determination. In addition, it is sent to the antenna control unit (ACU) in image reception and processing center so as to get mission data efficiently and to gain the time for an interface between the satellites and the control station.

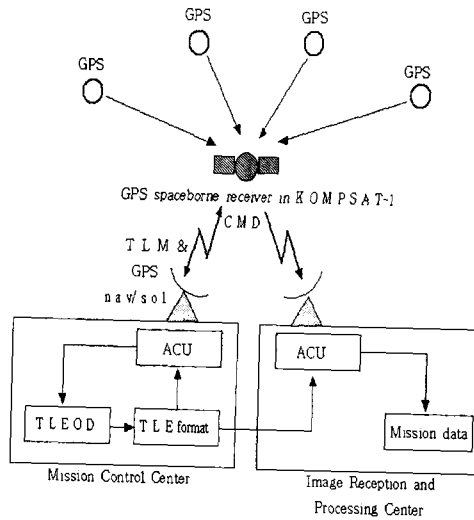

Figure 1. Process of orbit determination and its application.

3. ALGORITHM OF THE TLEOD SYSTEM

3.1 Transformation of the coordinate system

The GPS navigation solutions are osculating orbital elements given in the Earth Centered Fixed (ECF) coordinate system while computation values passing through NORAD SGP4 are osculating orbital elements provided in the Mean Equinox and True Equator (METE) coordinate system (Montenbruck et al. 2000). To transform both coordinate systems, the rotational conversion in value of Greenwich mean hour angle is required. After coordinate system transformation, observation-minus-computation values can be calculated as follows:

$$\rho = z - h(t) \quad (1)$$

where ρ means residual, z is the observation value, and h is the computational value as a function of time t .

3.2 State vector setup and estimation

NORAD SGP4 has a function that converts the NORAD TLE to the osculating position and velocity of the space objects in the orbit with time. Thus, the state variables are given in the form of the NORAD TLE as in Eq. (2)

$$y_i = f_i(e, i, \Omega, \omega, M, n, B^*), \quad i = 1, \dots, 7 \quad (2)$$

where $e, i, \Omega, \omega, M,$ and n stand for mean elements of the eccentricity, inclination, right ascension of ascending node, argument of perigee, mean anomaly, and anomalistic mean motion. B^* is the ballistic coefficient used in SGP4.

Taylor series is given by

$$\begin{aligned}
 f_i(e, i, \Omega, \omega, M, n, B^*) &= f_i(e^{(a)}, i^{(a)}, \Omega^{(a)}, \omega^{(a)}, M^{(a)}, n^{(a)}, B^{*(a)}) \\
 &+ \frac{\partial f_i}{\partial e^{(a)}}(e - e^{(a)}) + \frac{\partial f_i}{\partial i^{(a)}}(i - i^{(a)}) \\
 &+ \dots + \frac{\partial f_i}{\partial B^{*(a)}}(B^* - B^{*(a)})
 \end{aligned} \quad (3)$$

where superscript (a) stands for the around neighborhood of each orbital element.

The higher order term in Eq. (3) can be neglected under the assumption that a reasonably good approximation for the NORAD TLE. Eq. (3) is simplified as a system of seven linear equations.

$$\begin{aligned}
 \Delta y_{ki} &= M \cdot \Delta x_j, \\
 i &= 1, 2, \dots, n; \quad j = 1, 2, \dots, 7; \quad k = 1, 2, \dots, 6
 \end{aligned} \quad (4)$$

where Δy_{ki} and Δx_j are the difference between the real value and approximated value, and M is the $6n \times 7$ matrix of the partial derivatives of f_i with respect to the seven NORAD TLE. Especially, M is a differential correction matrix that linearizes differential equation. Through the linearization, we can calculate the equation of the motion with partial derivative.

$$M = \begin{bmatrix} \frac{\partial x_i}{\partial e_0} & \frac{\partial x_i}{\partial i_0} & \frac{\partial x_i}{\partial \Omega_0} & \frac{\partial x_i}{\partial \omega_0} & \frac{\partial x_i}{\partial M_0} & \frac{\partial x_i}{\partial n_0} & \frac{\partial x_i}{\partial B^*} \\ \frac{\partial y_i}{\partial e_0} & \frac{\partial y_i}{\partial i_0} & \frac{\partial y_i}{\partial \Omega_0} & \frac{\partial y_i}{\partial \omega_0} & \frac{\partial y_i}{\partial M_0} & \frac{\partial y_i}{\partial n_0} & \frac{\partial y_i}{\partial B^*} \\ \frac{\partial z_i}{\partial e_0} & \frac{\partial z_i}{\partial i_0} & \frac{\partial z_i}{\partial \Omega_0} & \frac{\partial z_i}{\partial \omega_0} & \frac{\partial z_i}{\partial M_0} & \frac{\partial z_i}{\partial n_0} & \frac{\partial z_i}{\partial B^*} \\ \frac{\partial \dot{x}_i}{\partial e_0} & \frac{\partial \dot{x}_i}{\partial i_0} & \frac{\partial \dot{x}_i}{\partial \Omega_0} & \frac{\partial \dot{x}_i}{\partial \omega_0} & \frac{\partial \dot{x}_i}{\partial M_0} & \frac{\partial \dot{x}_i}{\partial n_0} & \frac{\partial \dot{x}_i}{\partial B^*} \\ \frac{\partial \dot{y}_i}{\partial e_0} & \frac{\partial \dot{y}_i}{\partial i_0} & \frac{\partial \dot{y}_i}{\partial \Omega_0} & \frac{\partial \dot{y}_i}{\partial \omega_0} & \frac{\partial \dot{y}_i}{\partial M_0} & \frac{\partial \dot{y}_i}{\partial n_0} & \frac{\partial \dot{y}_i}{\partial B^*} \\ \frac{\partial \dot{z}_i}{\partial e_0} & \frac{\partial \dot{z}_i}{\partial i_0} & \frac{\partial \dot{z}_i}{\partial \Omega_0} & \frac{\partial \dot{z}_i}{\partial \omega_0} & \frac{\partial \dot{z}_i}{\partial M_0} & \frac{\partial \dot{z}_i}{\partial n_0} & \frac{\partial \dot{z}_i}{\partial B^*} \end{bmatrix} \quad (5)$$

where subscript i means the number of observation data and subscript 0 means the initial epoch.

3.3 Data editing

The data editing procedures for the TLEOD system have automatic editing depending on the weighted residual being compared to a given rejection level. The automatic editing of bad observations from a set of data during a data reducing run is performed through the same method as GEODYN II (McCarthy et al. 1993). Observation are rejected when

$$\left| \frac{O - C}{\sigma} \right| > k \quad (6)$$

where O is the observation data, C is the computed value, σ is the a priori standard deviation associated with the observation, k is the rejection level. The rejection level can apply either for all observations of a given type or for all observations of a given type from a particular station. This rejection level is computed from

$$k = E_M \cdot E_R \quad (7)$$

where E_M is an input multiplier and E_R is the weighted RMS of the previous outer or global iteration. The initial value of E_R is set on input. In this system, E_M is given the value of 4.5. E_R also has the value of 200 as an initial: afterward, its value is updated with the result of RMS value in residuals.

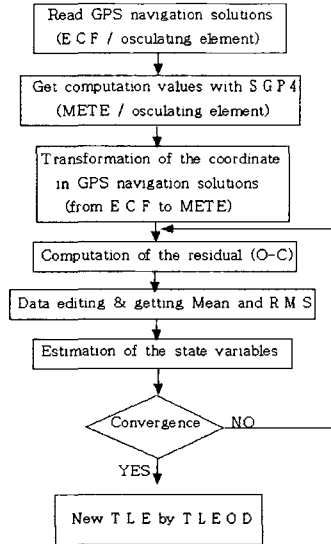

Figure 2. Computational flow of the TLEOD system.

3.4 Estimation of state variables

In linearizing Eq. (4), the equation is converted to the following:

$$\Delta y = H \Delta \hat{x} \quad (8)$$

where H is another representation of M in Eq. (5), and $\Delta \hat{x}$ are the variation of the state variables.

Multiplying the transpose of H in both terms, following equation will be gotten.

$$H^T \Delta y = H^T H \Delta \hat{x} \quad (9)$$

Thus, we can get the variation of the state variables given by

$$\Delta \hat{x} = (H^T H)^{-1} H^T \Delta y \quad (10)$$

where H is $6n \times 7$ matrix, $\Delta \hat{x}$ is 7×1 matrix, and Δy is $6n \times 1$ matrix. Finally, we can get the last value of the state variables given by

$$x_{i+1} = x_i + \Delta \hat{x} \quad (11)$$

where the subscript i means iteration number.

Figure 2 shows the computational flow of the TLEOD system. Details about each step are already introduced in the above sections.

4. ORBIT DETERMINATION RESULTS

4.1 Comparison of the orbit propagation among the TLE

The Orbit Propagation (OP) difference in the NORAD TLE is shown in Figure 3. The OP from NORAD TLE in Feb. 14 and 17, 2001 is compared. As shown in Figure 3, the OP difference after one day is within 5km, and that after seven days is within 30 km.

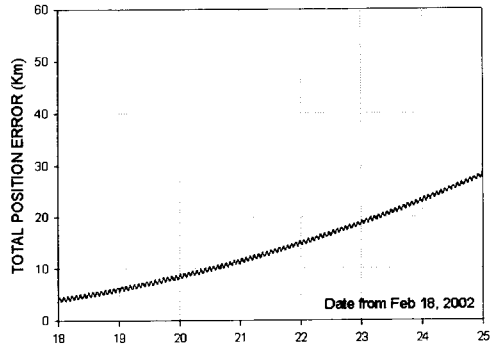

Figure 3. OP difference between the NORAD TLE in Feb. 14, 2001 and the NORAD TLE in Feb. 17, 2001.

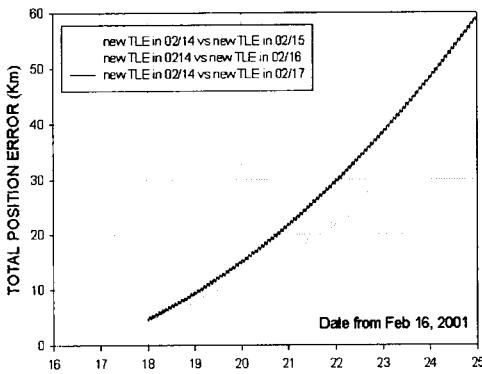

Figure 4a. OP difference by the initial TLE using 1 day observation data.

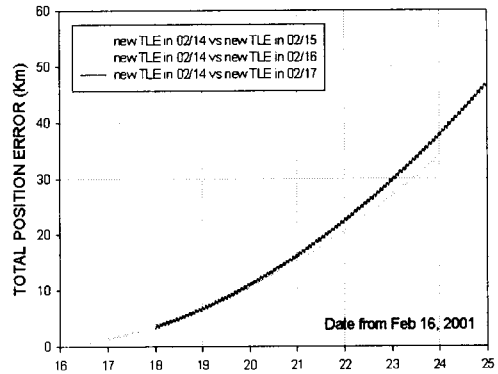

Figure 4b. OP difference by the initial TLE using 2 days observation data.

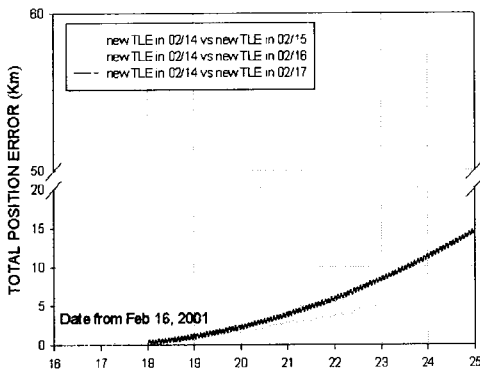

Figure 4c. OP difference by the initial TLE using 3 days observation data.

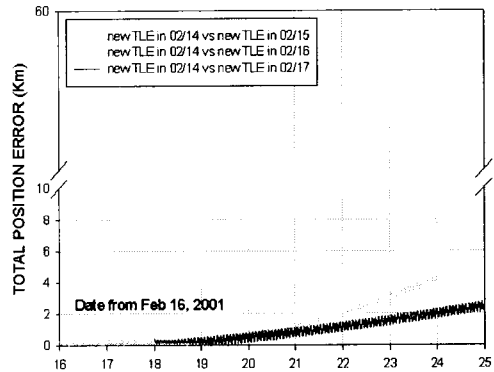

Figure 4d. OP difference by the initial TLE using 4 days observation data.

Table 1. Comparison of the OP difference and B* value among the spans of the observation data.

Number	OP difference		B* value
1 day	After 1 day: 2 km	After 7 days: 30 km	From 0.00009 to 0.00057
2 days	After 2 days: 4 km	After 7 days: 35 km	From 0.00020 to 0.00048
3 days	After 3 days: 1 km	After 7 days: 7 km	From 0.00021 to 0.00039
4 days	After 4 days: 1 km	After 7 days: 3 km	From 0.00023 to 0.00037

Next, the OP difference of a newly estimated TLE by the TLEOD is compared. NORAD TLE is not used in this cases. Using the TLEOD, four kinds of a new TLE are estimated depending on the span of the day in the observation data. In each case, the OP results by the estimated TLE in Feb. 15, 16, and 17, 2001 are compared with the OP by the estimated TLE in Feb. 14, 2001. As the day passes, the OP difference is getting more and more. In Figure 4a, the estimated TLE with 1 day observation data is propagated by SGP4. In case of the TLE in Feb. 14 and Feb. 17, the OP difference after one day is about 5 km, and that after seven days is within 60 km. In Figure 4b, using the TLE updated with 2 days observation data, the OP is run. Its difference decreases more than that of the TLE with 1 day observation data. In case of using 3 days observation data as shown in Figure 4c, the OP difference after one day is within 1 km, and that after seven days is about 15 km. In case of using 4 days observation data, the OP difference is within 3 km even after seven days in Figure 4d.

4.2 Comparison of B* values

Of the NORAD TLE, the most random value is the value of B*. This is because the objects tracked by NORAD are too many to get precise value. Theoretically, the value of ballistic coefficient has to increase according as the time is passing away because the altitude of the satellite is dropping slowly. However, the tendency of the value of B* in the NORAD TLE is irregular as shown in Figure 5. The large extent has the value of 0.0002.

To find the effect of B* value, B* value in a TLE in Feb. 14, 2001 is replaced by B* value in a TLE in Feb. 15, 2001 and B* value in a TLE in Feb. 20, 2001. The former B* value has the smallest difference with that in Feb. 14, 2001, and the latter B* value has the largest difference with that in Feb. 14, 2001. Figure 6 represents the difference of both cases. In the first case, the OP difference is just 2 km in seven days. In the second case, The OP difference after one day is about 2 km, and that after seven days is over 30 km. Thus, the fact that the variation of B* value affects the precision of the orbit can be recognized.

In case of using 1 day observation data as shown in Figure 7a, its tendency has more random than that of the NORAD TLE. The difference between the largest value and the smallest one is about 0.0005. However, the tendency of B* value in case of using 2 days, 3 days, and 4 days observation is getting more regular as shown in Figure 7b, Figure 7c, and Figure 7d.

4.3 Selection of the span of the day in the observation data

To operate the mission efficiently and get the OD more precisely, the comparison of both the OP result and B* value is required. The features about each case are shown in Table 1. To consider the pure OP difference, the OP difference after the span of the day in the observation data is compared. In case of 1 day, the OP difference in 1 day after the OD is greater than other cases, and B* value also has the large extent. In case of 2 days, the OP difference has the same result as the case of 1 day. However, in the case of 3 days and 4 days, the OP difference after the span of the day in the observation data has smaller value than the OP difference after 1 day in the case of 1 day. In

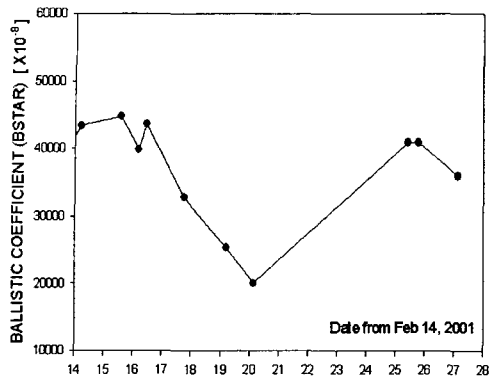

Figure 5. Tendency of B* value in the NORAD TLE.

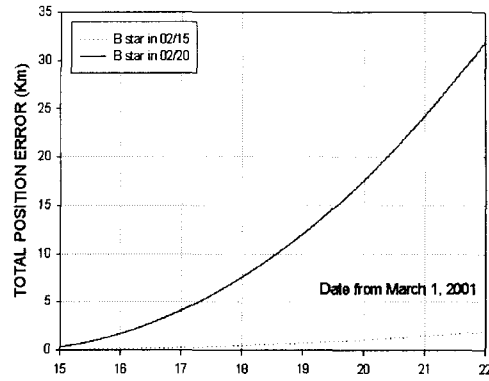

Figure 6. OP difference by the TLE when B* value is changed.

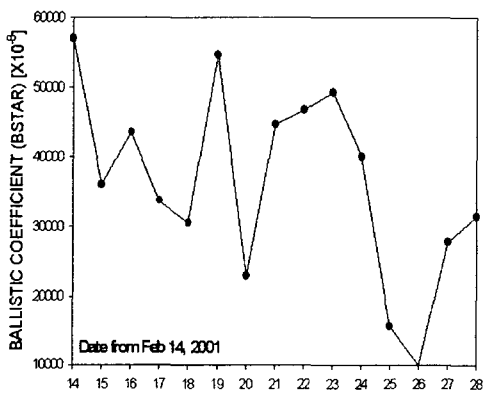

Figure 7a. Tendency of estimated B* values using 1 day observation data.

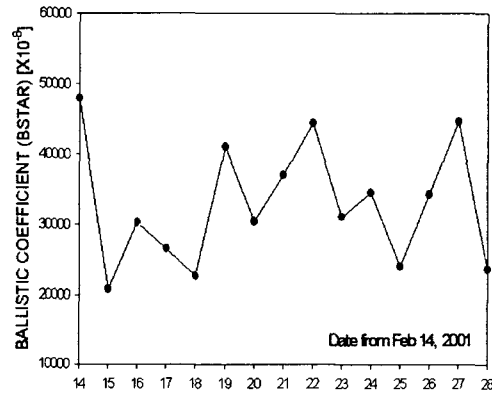

Figure 7b. Tendency of estimated B* values using 2 days observation data.

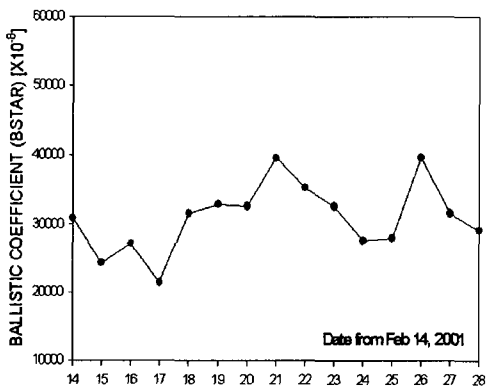

Figure 7c. Tendency of estimated B* values using 3 days observation data.

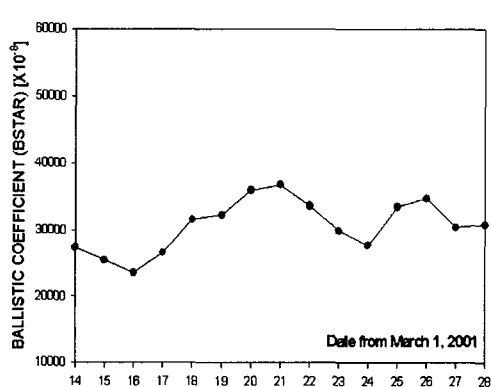

Figure 7d. Tendency of estimated B* values using 4 days observation data.

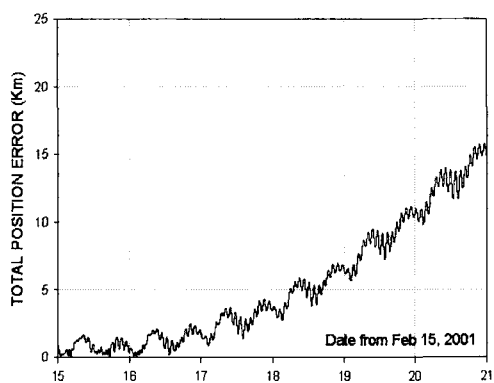

Figure 8a. OP difference between SGP4 and MAPS in case of the NORAD TLE.

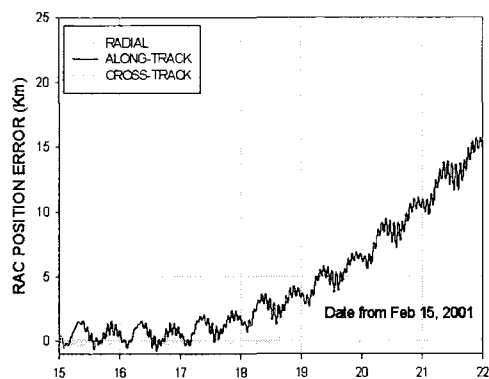

Figure 8b. OP difference between SGP4 and MAPS in case of the NORAD TLE in RAC.

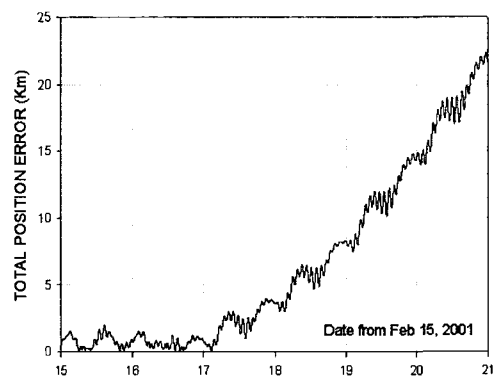

Figure 9a. OP difference between SGP4 and MAPS using 1 day observation data.

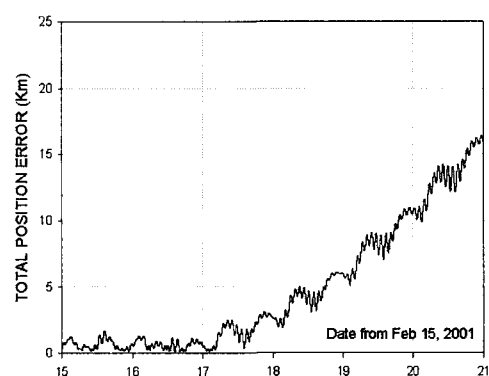

Figure 9b. OP difference between SGP4 and MAPS using 2 days observation data.

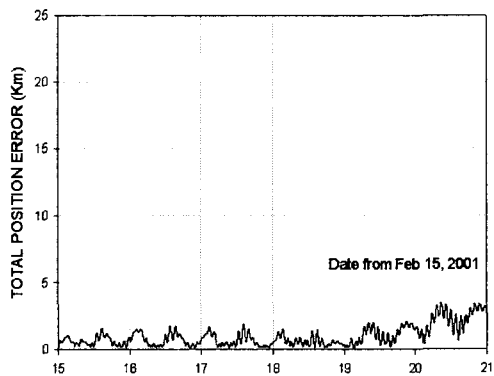

Figure 9c. OP difference between SGP4 and MAPS using 3 days observation data.

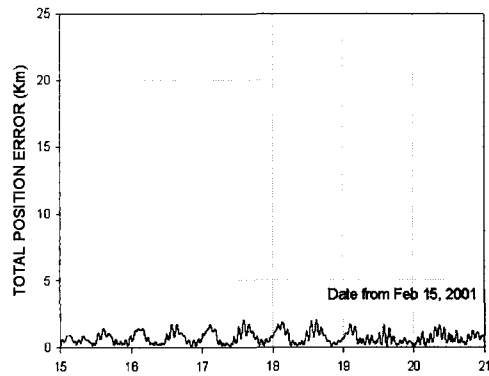

Figure 9d. OP difference between SGP4 and MAPS using 4 days observation data.

addition, the extent of B^* value is small. Thus, the case of 3 days is suitable to the span of the day in the observation data in the TLEOD while the case of 4 days has the better result. This is because the difference between both cases is analogous and one day must be awaited for the OD.

4.4 Comparison between SGP4 and MAPS

The OP difference between an analytical method and a numerical method is compared. The OP in the analytical method is obtained by SGP4 using the TLE in Feb. 14, 2001. For the numerical OP, the results of Mission Analysis and Planning Subsystem (MAPS) for the KOMPSAT-1 are used. To compare the results of the NORAD TLE with that of MAPS, the total position error increases upto the value of 2 km after two days and within 16 km after seven days as shown in Figure 8a. Its difference mainly is due to along-track error as shown in Figure 8b. In case of using a TLE by 1 day observation data, the total position error increases upto the value of 23 km after seven days as shown in Figure 9a. Figure 9b shows the OP difference with a TLE by 2 days observation data. Its value is similar to that of the NORAD TLE. In case of using 3 days observation as shown Figure 9c, the total position error has the value within 4 km even after seven days. Lastly, case of using 4 days observation is shown in Figure 9d. Its value is within 2km after seven days.

5. CONCLUSIONS

The TLEOD system that provides the OD result in the type of the NORAD TLE was developed and tested. GPS navigation solutions were used as observation data, and SGP4 was used as an orbit propagator. In the mathematical model, a least squares method was applied to get the state variables. For the test of this system, we determined the orbit of the KOMPSAT-1. To choose the preferable span of the observation data, the OP difference was compared in various cases. Also, the tendency of B^* value was compared. Considering both values, the preferable span of the day in the observation data was found as 3 days. In conclusion, through the OD using 3 days in the observation data, the OP difference was derived from SGP4. Its value after one day was within 1 km, and that after seven days was within 7 km. The OP difference between SGP4 and MAPS also had the value from 2 km to 4 km. Moreover, this result was qualified enough for the efficiency of the ground antenna control unit in image reception and processing center of the KOMPSAT-2.

REFERENCES

- Jochim, E. F., Gill, E., Montenbruck, O., & Kirschner, M. 1996, *Acta Astronautica*, 39, 917
- Lee, B.-S., Lee, J.-S., Kim, J.-H., Kim, H.-D., Kim, E.-K., & Choi, H.-J. 2001, Estimation of Atmospheric Drag and Solar Radiation Pressure Coefficients in the KOMPSAT-1 Orbit Determination, *Proceedings of the KSAS Annual Meeting 2001*, 579
- McCarthy, J. J., Rowton, S., Moore, D., Pavlis, D. E., Luthcke, S. B., & Tsaoussi, L. S. 1993, *GEODYN II-Systems Description vol.1 (NASA: GSFC)*, pp.173-174
- Montenbruck, O. 2000, *Aerospace Science Technology*, 4, 277
- Montenbruck, O., Gill, E., & Kayal, H. 2000, The BIRD Satellite Mission as a Milestone Towards GPS-based Autonomous Navigation, *ION-GPS 2000 Conference*, paper C5-1