

Design and Analysis of Dynamic Positioning System Using a Nonlinear Robust Observer

MYUNG-HYUN KIM*

*Research and Development, New York Power Authority
123 Main Street, White Plains, NY, 10601 U.S.A.

KEY WORDS: Dynamic Positioning, Sliding Mode Observer, Observer Backstepping

ABSTRACT: 본 연구는 슬라이딩 모드개념을 이용한 비선형 견실 상태 추정기의 선박 위치제어시스템에 대한 적용에 관한 연구이다. 개발된 상태추정기는 제어기 설계에 필요한 동적 모델에 있어서 고려되지 않은 비선형성과 불확실성 및 외란이 존재하더라도 견실히 상태추정을 수행할 수 있는 장점을 가지고 있다. 또한 선박의 속도 및 유체력으로 인한 외란의 추정이 가능하며, 파랑으로 인한 고주파 운동응답을 여과시킴으로 불필요한 작동기의 동작과 과도한 연료손실을 방지할 수 있다. 특히 상태 추정기에 불연속 함수를 도입함으로써 비선형성, 외란 및 불확실성에 대해 강인한 특성을 가지고 있다. 제안된 상태추정기에 기초하여 Observer backstepping 방법을 이용한 위치 제어기가 설계되었으며, 제어시스템의 안정성을 Lyapunov 법을 이용하여 검증하였다. 일련의 수치 시뮬레이션을 수행함으로써 제안된 상태추정기 및 제어기의 선박위치제어시스템으로서의 성능을 예측하였다.

1. Introduction

The control task for marine vehicles including ships, submarines, and underwater vehicles is a challenging problem since the dynamics of marine vehicles is nonlinear, time varying and uncertain. Moreover, environmental disturbances make the control task more difficult. Various advanced control methods have been developed in the last a few decades to meet increasing demands on the performance especially in the robotics community. All of the aforementioned feedback controllers, however, require measurements of all the states for feedback, which is impractical and sometimes impossible.

In marine vehicles, linear translational velocities such as heave, surge, and sway velocities are difficult to measure compared to other states. The control signal requires the measurement of the linear translational velocity components in addition to the position and attitude of the vehicle. Usually, linear translational velocities are obtained by a model-based state estimation through noisy position measurements. Considering the coupled and highly nonlinear dynamics of marine vehicles, a nonlinear observer needs to be used to estimate the linear translational velocities of marine vehicles.

Several nonlinear observer techniques have been developed in robotics community. (Slotine et al., 1987) present a sliding mode observer using a similar concept to the sliding mode

control. It is expected that the sliding mode observer will provide robust state reconstruction in the presence of uncertainties and disturbances. (Nicosia and Tomei, 1990) proposed a simple linear observer, in which high gains are used to attenuate the nonlinearities that characterize the robot dynamics. (Berghuis and Nijmeijer, 1993) developed a new approach to the observer design problem using the passivity-based controller design concept and showed a strategy to construct a controller and an observer considering the dynamics of the both controller and observer simultaneously. (Misawa, 1988) showed basic concepts of the sliding mode observer for second order systems in his dissertation. Although there is a clear description of the principle for second order systems derived from phase plane analysis, it is shown that the design rules drawn from the second order system are not sufficient to guarantee stable observers for higher order systems. He showed that the additional requirement of strict positive realness of the linear part of the system is necessary. However, the use of the sliding observer inside a control loop is not considered in his dissertation.

For marine vehicles, (Fossen and Strand, 1999) developed a nonlinear observer that is shown to be globally exponentially stable (GES) through a passivity design. Using the nonlinear observer, no linearization of the kinematic equation is necessary, resulting in a fewer number of tuning parameters compared to that of the Kalman filter. An output feedback controller is derived using the backstepping based on the observer.

In this study, a robust nonlinear observer of (Fossen and Strand, 1999) is extended utilizing the sliding mode observer

제1저자 김명현 연락처: 1-914-287-3811 U.S.A.
myung.kim@nypa.gov

technique. A new stability interpretation is performed with the proposed observer. (Kim and Inman, 2001) used the sliding mode observer technique and applied it to a problem of dynamic positioning of ships. The observer needs to be able to estimate linear velocities of the ship and bias from slowly varying environmental loads. It also needs to be able to filter out wave frequency signal since feedback of the wave frequency signal will cause wear of the actuators and excessive fuel consumption. The main advantage of the proposed observer is in its robustness. Since the mathematical model for dynamic positioning of a ship is difficult to obtain and includes uncertainties and disturbances, it is very important for the observer to be robust.

2. Mathematical Model for Dynamic Positioning (DP) of Ships

The objective of dynamic positioning (DP) systems in ships is to maintain the marine vessel in a fixed position and heading in the horizontal plane or to follow a predetermined track by means of the ship propulsion system. A brief mathematical model for dynamics positioning of a ship is discussed, and it can also be found in (Fossen, 1994). A typical schematic of a DP ship and coordinate system is shown in Fig. 1.

The equations of motion of DP ships in surge, sway and yaw can be described as

$$\begin{aligned} M\dot{\nu} + D\nu &= \tau + J^T(\phi)b + E_\nu w_\nu \\ \dot{\eta} &= J(\eta)\nu \end{aligned} \quad (1)$$

where M is the inertia matrix including hydrodynamic added inertia, and D is the damping matrix. Here $\nu = [u, v, r]^T$ is

the body-fixed linear velocity vector, and $\eta = [X, Y, \phi]^T$ is the position and yaw angle in the earth-fixed coordinate.

The control forces and moment $\tau \in R^3$ provided by thrusters and the current $b \in R^3$ acting on the vehicle are considered to be external forces. The transformation matrix is denoted as $J(\phi)$. The uncertainties and disturbances in the ship dynamics are described by $E_\nu w_\nu$ where w_ν is a zero mean Gaussian white noise and E_ν a diagonal matrix scaling the amplitude of w_ν . The properties

$M = M^T > 0$, $\dot{M} = 0$ and $D > 0$ are used extensively in the development of the controller and the observer in the following sections.

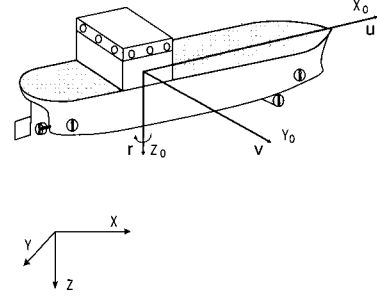

Fig. 1 Schematic of a DP ship

A common bias model for marine vehicle control is

$$\dot{b} = -T^{-1}b + \Psi n \quad (2)$$

where n is a zero mean bounded disturbance vector, T is a diagonal matrix of bias time constants, and Ψ is a diagonal matrix scaling the amplitude of n . The bias model accounts for slowly varying forces and moments due to 2nd-order wave loads, ocean currents and wind.

Wave forces can be divided into 1st-order wave disturbances and 2nd-order wave drift forces. For the practical control system design purpose, 1st-order wave disturbances can be described by three harmonic oscillator with some damping. Linear 2nd-order wave forces are modeled as

$$\begin{aligned} \dot{\xi} &= A_w \xi + E_\xi w_\xi \\ \eta_w &= C_w \xi \end{aligned} \quad (3)$$

where $\eta_w = [x_w, y_w, \psi_w]^T$, and $w_\xi \in R^3$ is a zero mean bounded disturbance vector and

$$A_w = \begin{bmatrix} 0 & I \\ -\Omega^2 & -2\Lambda\Omega \end{bmatrix}, E_w = \begin{bmatrix} 0 \\ I \end{bmatrix}, C_w = [0 \quad I] \quad (4)$$

where $\Omega = \text{diag}\{\omega_1, \omega_2, \omega_3\}$, $\Lambda = \text{diag}\{\zeta_1, \zeta_2, \zeta_3\}$, and $\overline{E_w} = \text{diag}\{\overline{E_{w1}}, \overline{E_{w2}}, \overline{E_{w3}}\}$. Here $\omega_i (i=1, \dots, 3)$ are wave frequency and $\zeta_i (i=1, \dots, 3)$ are relative damping ratios typically chosen less than 1.0.

The measurement can be written as

$$y = \eta + \eta_\xi + y_n \quad (5)$$

where y_n is the zero mean Gaussian white measurement noise. It is assumed that the total position of the ship can be obtained by superposition of the position and direction of the ship and wave displacements.

3. Robust Nonlinear Observer for DP of Ships

3.1 The Observer Structure

This section describes how to design a sliding mode observer which is known to be robust to certain types of bounded modeling errors and/or disturbance inputs. Considering the mathematical model developed in the previous section, the sliding mode observer can be designed as

$$\begin{aligned}\dot{\hat{\xi}} &= A_w \hat{\xi} + H_1 \hat{y} \\ \dot{\hat{\eta}}_w &= J(y) \hat{\nu} + H_2 \hat{y} + \overline{K} \text{sat}(\hat{z}) \\ \dot{\hat{b}} &= -T^{-1} \hat{b} + H_3 \hat{y} \\ M \dot{\hat{\nu}} &= -D \hat{\nu} + \tau + J^T \hat{b} + J^T H_4 \hat{y} \\ \hat{y} &= \hat{\eta} + C_w \hat{\xi}\end{aligned}\quad (6)$$

where $H_i (i=1, \dots, 4)$ and \overline{K} are observer gains and the variables with hat denoting estimates. The saturation function $\text{sat}(\hat{z})$ is defined as

$$\text{sat}(\hat{z}/\varepsilon) = \begin{cases} \hat{z}/|\hat{z}| & \text{if } |\hat{z}| \geq \varepsilon \\ \hat{z}/\varepsilon & \text{if } |\hat{z}| < \varepsilon \end{cases}\quad (7)$$

with \hat{z} which will be defined later. The observer error dynamics can be obtained as

$$\begin{aligned}\dot{\tilde{\xi}} &= A_w \tilde{\xi} - H_1 \tilde{y} \\ \dot{\tilde{\eta}}_w &= J(y) \tilde{\nu} - H_2 \tilde{y} - \overline{K} \text{sat}(\tilde{z}) \\ \dot{\tilde{b}} &= -T^{-1} \tilde{b} - H_3 \tilde{y} \\ M \dot{\tilde{\nu}} &= -D \tilde{\nu} + \tau + J^T \tilde{b} - J^T H_4 \tilde{y} + E_v w_v \\ \tilde{y} &= \tilde{\eta} + C_w \tilde{\xi}\end{aligned}\quad (8)$$

where $\tilde{\xi} = \xi - \hat{\xi}$, $\tilde{\nu} = \nu - \hat{\nu}$, $\tilde{b} = b - \hat{b}$ and $\tilde{\eta} = \eta - \hat{\eta}$.

Defining $\tilde{x} = [\tilde{\xi}^T, \tilde{\eta}^T, \tilde{b}^T]^T$, the equation (8) can be combined into

$$\begin{aligned}\dot{\tilde{x}} &= A \tilde{x} + B J(y) \tilde{\nu} - K \text{sat}(\tilde{z}) \\ \dot{\tilde{z}} &= C \tilde{x} \\ M \dot{\tilde{\nu}} &= -D \tilde{\nu} - J^T \tilde{z} + E_v w_v\end{aligned}\quad (9)$$

where A , B and C have the values:

$$A = \begin{bmatrix} A_w - H_1 C_w & -H_1 & 0 \\ -H_2 C_w & -H_2 & 0 \\ -H_3 C_w & -H_3 & -T^{-1} \end{bmatrix}, \quad B = \begin{bmatrix} 0 \\ I \\ 0 \end{bmatrix}\quad (10)$$

$$C = [C_w \quad H_4 \quad -I], \quad K = \begin{bmatrix} 0 \\ \overline{K} \\ 0 \end{bmatrix}$$

The equation (9) can be represented as a feedback form shown in Fig. 2. The feedback system is composed of the subsystems Σ_1 and Σ_2 , and the stability of the feedback system will be shown in the following section. The significance of the above modeling is to include the effect of

disturbance w_v , which represents the modeling error and uncertainties in ship dynamics. Since the dynamic model of DP ships includes both parametric uncertainties and structural uncertainties, it is important to design an observer having robustness against those undesirable effects.

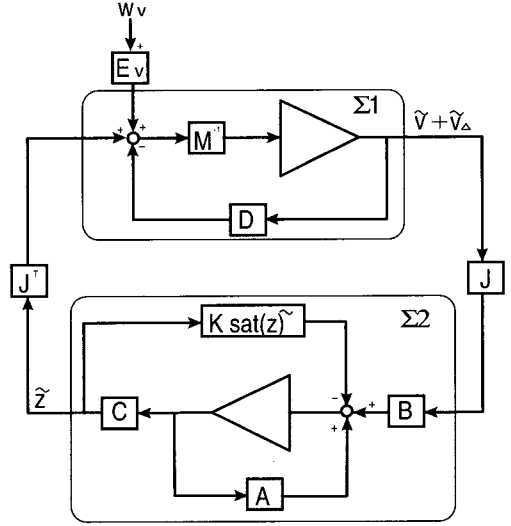

Fig. 2 Observer feedback configuration

3.2 Stability Analysis

The passivity approach is taken in this study to provide conditions that will ensure the stability of the feedback system in Fig. 2. The main idea lies in that every nonlinear passive system controlled by a passive control system is closed-loop stable (Khalil, 1996). The passivity and stability of the subsystem Σ_1 can be derived by showing that the subsystem is state strictly passive. For the subsystem Σ_1 , take Lyapunov function as

$$V = \tilde{\nu}^T M \tilde{\nu}\quad (11)$$

Noting that M is positive definite and denoting $-J^T \tilde{z}$ as ε_z , the passivity of the subsystem Σ_1 can be proved as

$$\begin{aligned}\tilde{\nu}^T \varepsilon_z &= \dot{V} + \tilde{\nu}^T (D^T + D) \tilde{\nu} \\ &\geq \dot{V} + \frac{1}{2} \lambda_{\min}(D^T + D) \tilde{\nu}^T \tilde{\nu}\end{aligned}\quad (12)$$

implying the state strict passivity with λ_{\min} denoting the minimum eigenvalue. Consequently, the asymptotic stability of $\tilde{\nu} = 0$ can be concluded. The output from the vehicle dynamics, represented as $\tilde{\nu} + \tilde{\nu}_\Delta$, is composed of the output from the vehicle dynamics $\tilde{\nu}$ plus the output $\tilde{\nu}_\Delta$ from the disturbance $E_v w_v$. The objective is to design a sliding mode observer that will provide estimates of state \hat{x}

which is an approximation of the actual state x in the presence of the modeling errors and disturbance E, w, ν . Note that the sliding mode observer is basically the conventional Luenberger observer with the additional switching term $Ksat(\tilde{z})$ that will be used to guarantee robustness against modeling errors and disturbances. As we choose $K=B\Theta$ with $\Theta=diag(\rho_i)$ and consider the asymptotic stability of $\tilde{\nu}$, the error dynamics results in the form

$$\dot{\tilde{x}} = A\tilde{x} - K(sat(\tilde{z}) - \Theta^{-1}J(y)\tilde{\nu}_d) \quad (13)$$

According to the passivity theorem, described in (Misawa, 1988), it can be shown that the state estimation errors go asymptotically to zero as long as the observer satisfies the following relationship, which is known to be Kalman-Yakubovich-Popov lemma (positive real lemma) for positive definite matrices $P=P^T$ and $Q=Q^T$.

$$\begin{aligned} PA + A^T P &= -Q \\ B^T P &= C \end{aligned} \quad (14)$$

The linear observer gain H is obtained from the requirement to satisfy the KYP lemma equations for the subsystem Σ_2 . Considering the effect of the disturbance w, ν explicitly, equation (9) can be rewritten as

$$\begin{aligned} \dot{\tilde{x}} &= A\tilde{x} + BJ(y)(\tilde{\nu} + \tilde{\nu}_d) - Ksat(\tilde{z}) \\ \dot{\tilde{z}} &= C\tilde{x} \\ M\dot{\tilde{\nu}} &= -D\tilde{\nu} - J^T\tilde{z} + E, w, \nu \end{aligned} \quad (15)$$

Lyapunov function is chosen in the form of

$$V = \tilde{x}^T P \tilde{x} + \tilde{\nu}^T M \tilde{\nu} \quad (16)$$

where P is a symmetric positive definite matrix. Taking the time derivative of the Lyapunov function, equation (16), we obtain

$$\begin{aligned} \dot{V} &= -\tilde{x}^T Q \tilde{x} - \tilde{\nu}^T (D^T + D) \tilde{\nu} + 2\tilde{x}^T P B \tilde{\nu} \\ &\quad - 2\tilde{\nu}^T J^T \tilde{z} + 2\tilde{x}^T P B J \tilde{\nu}_d - 2\tilde{x}^T P K sat(\tilde{z}) \\ &= -\tilde{x}^T Q \tilde{x} - \tilde{\nu}^T (D^T + D) \tilde{\nu} + 2\tilde{z}^T J \tilde{\nu}_d \\ &\quad - 2\tilde{z}^T \Theta sat(\tilde{z}) \end{aligned} \quad (17)$$

As we select ρ_i to satisfy the relation $\|\Theta\| \geq \|\tilde{\nu}_d\|$, it can be shown that the time derivative of the Lyapunov function is negative definite, which implies asymptotic stability of the states \tilde{x} .

4. Observer Backstepping with the Nonlinear Observer

4.1 Nonlinear Controller Design using Observer Backstepping

Nonlinear backstepping technique is utilized to obtain the output feedback controller which makes the closed-loop system stable. It is assumed that a smooth desired trajectory in earth-fixed coordinate $\eta_d = [\eta_d, \dot{\eta}_d, \ddot{\eta}_d]^T$ are generated from a proper reference trajectory generator. The objective of the controller is to provide a proper control action that enables the ship to follow the desired position and heading. Define the error variable z_1 as

$$z_1 = \hat{\eta} - \eta_d + K_I \int_0^t (\hat{\eta} - \eta_d) dr = \dot{e}_I + K_I e_I \quad (18)$$

where K_I is the gain for the integral action to eliminate steady state errors and $\dot{e}_I = \hat{\eta} - \eta_d$. Taking the time derivative of equation (18) yields

$$\begin{aligned} \dot{z}_1 &= \hat{\eta} - \dot{\eta}_d + K_I (\hat{\eta} - \eta_d) \\ &= \hat{f}\nu + H_2 \hat{y} + \overline{K} sat(\tilde{z}) - \dot{\eta}_d + K_I (\hat{\eta} - \eta_d) \end{aligned} \quad (19)$$

Choosing the virtual control $\xi_1 = \hat{f}\nu = z_2 + \alpha_1$ with the stabilizing function $\alpha_1 = -C_1 z_1 - D_1 \dot{z}_1 + \dot{\eta}_d - K_I (\hat{\eta} - \eta_d)$ equation (19) results in

$$\dot{z}_1 = -(C_1 + D_1) z_1 + z_2 + H_2 \hat{y} + \overline{K} sat(\tilde{z}) \quad (20)$$

where C_1 is a strictly positive constant feedback design matrix, and D_1 is a positive diagonal damping matrix. The matrix D_1 is used to compensate for the disturbance from the estimation errors and is composed of the column vectors of H_1^T and \overline{K}^T in the observer equations. Next, define the second error variable $z_2 = \xi_1 - \alpha_1 = \hat{f}\nu - \alpha_1$. Taking the time derivative of z_2 , we obtain

$$\dot{z}_2 = \hat{f}\nu + \dot{f}\nu + (C_1 + D_1) \dot{z}_1 - \ddot{\eta}_d + K_I \dot{\hat{\eta}} - K_I \dot{\eta}_d \quad (21)$$

The term $\dot{f}\nu$ can be expressed in terms of estimates and estimation errors as developed in (Aarset et al., 1998)

$$J(y)\hat{\nu} = J(y)S(\hat{\mu})\hat{\nu} + J(y)S(\hat{\nu})(L\hat{\nu} + N\hat{\xi}) \quad (22)$$

where $\mu = [0, 0, r + \dot{\psi}_w]^T$ with r defining the yaw rate, $L = diag(0, 0, 1)$, N is 3×6 matrix with all zero terms except $N(3, 6) = 1$, and S is a skew-symmetric matrix. Inserting (22) into (21) and defining A as

$$\Lambda = JS\hat{\nu} - JM^{-1}\hat{\nu} + JM^{-1J^T}\hat{b} - (C_1 + D_1)^2 z_1 + (C_1 + D_1)z_2 - K_I\hat{\eta}_d + K_{II}\hat{\nu} - \hat{\eta}_d \quad (23)$$

equation (21) can be written as

$$\dot{z}_2 = JSL\hat{\nu} + JSN\hat{\xi} + \Lambda + JM^{-1}\tau + [JM^{-1}J^TH_4 + (C_1 + D_1)H_2 + K_IH_2]\hat{y} + [(C_1 + D_1)\bar{K} + K_I\bar{K}]sat(\hat{z}) \quad (24)$$

Now choosing a control input as

$$\tau = -(JM^{-1})^{-1}[\Lambda + C_2z_2 + D_2z_2 + z_1] \quad (25)$$

the resulting z_2 error dynamics becomes

$$\dot{z}_2 = -(C_2 + D_2)z_2 - z_1 + \Omega_1\hat{y} + \Omega_2\hat{\nu} + \Omega_3\hat{\xi} + \Omega_4sat(\hat{z}) \quad (26)$$

with the obvious definition of $\Omega_i (i=1, \dots, 4)$. The matrix

C_2 is a strictly positive feedback design matrix and D_2 is a positive diagonal damping matrix with column vectors from $\Omega_i (i=1, \dots, 4)$.

Defining $z = [z_1^T, z_2^T]^T$, the closed-loop system including the observer dynamics can be shown to be

$$\begin{aligned} \dot{z} &= -C_z z - D_z z + E z + W_1\hat{y} + W_2\hat{\nu} + W_3\hat{\xi} + W_4sat(\hat{z}) \\ \dot{e}_I &= \hat{\eta} - \eta_d \\ M\dot{\hat{\nu}} &= -D\hat{\nu} - J^T\hat{z} \\ \dot{\hat{x}} &= A\hat{x} + B(J(y)\hat{\nu} - Ksat(\hat{z})) \\ \dot{\hat{z}} &= c\hat{x} \end{aligned}$$

where

$$\begin{aligned} C_z &= \begin{bmatrix} C_1 & 0 \\ 0 & C_2 \end{bmatrix}, D_z = \begin{bmatrix} D_1 & 0 \\ 0 & D_2 \end{bmatrix}, E = \begin{bmatrix} 0 & I \\ -I & 0 \end{bmatrix}, \\ W_1 &= \begin{bmatrix} H_2 \\ \Omega_1 \end{bmatrix}, W_2 = \begin{bmatrix} 0 \\ \Omega_2 \end{bmatrix}, W_3 = \begin{bmatrix} 0 \\ \Omega_3 \end{bmatrix}, W_4 = \begin{bmatrix} \bar{K} \\ \Omega_4 \end{bmatrix} \end{aligned} \quad (28)$$

4.2 Stability Analysis

In this section, the stability analysis based on the closed-loop system is performed. The Lyapunov function is chosen considering both the controller and the observer as

$$V = V_{con} + V_{obs} = \frac{1}{2} z^T z + e_I^T K_I C_1 e_I + V_{obs} \quad (29)$$

The time derivative of the Lyapunov function can be shown

$$\begin{aligned} \dot{V} &= z^T \dot{z} + 2e_I^T K_I C_1 e_I + \dot{V}_{obs} \\ &= -z^T C_z z - z^T D_z z + z^T W_1 \hat{y} + z^T W_2 \hat{\nu} + z^T W_3 \hat{\xi} \\ &\quad + z^T W_4 sat(\hat{z}) + 2e_I^T K_I C_1 e_I - \hat{\nu}^T (D^T + D) \hat{\nu} \\ &\quad - \hat{x}^T Q \hat{x} + 2\hat{z}^T J \hat{\nu}_w - 2\hat{z}^T \Theta sat(\hat{z}) \end{aligned} \quad (30)$$

Adding and subtracting the following zero terms

$$\begin{aligned} \frac{1}{4} (\hat{y}^T G_1 \hat{y} - \hat{y}^T G_1 \hat{y}) &= 0, \frac{1}{4} (\hat{\nu}^T G_2 \hat{\nu} - \hat{\nu}^T G_2 \hat{\nu}) = 0 \\ \frac{1}{4} (\hat{\xi}^T G_3 \hat{\xi} - \hat{\xi}^T G_3 \hat{\xi}) &= 0, \frac{1}{4} (\hat{z}^T G_4 \hat{z} - \hat{z}^T G_4 \hat{z}) = 0 \end{aligned} \quad (31)$$

with $G_i (i=1, \dots, 4)$ as defined in (Fossen and Strand, 1999), and considering the relation:

$$\begin{aligned} z^T (W_1 \hat{y} + W_2 \hat{\nu} + W_3 \hat{\xi} + W_4 sat(\hat{z})) - \frac{1}{4} \hat{y}^T G_1 \hat{y} \\ - \frac{1}{4} \hat{\nu}^T G_2 \hat{\nu} - \frac{1}{4} \hat{\xi}^T G_3 \hat{\xi} - \frac{1}{4} \hat{z}^T G_4 \hat{z} \leq 0 \end{aligned} \quad (32)$$

equation (29) can be written as

$$\begin{aligned} \dot{V} &= -z^T C_z z - \hat{x}^T (Q - \frac{1}{4} C_y^T G_1 C_y - \frac{1}{4} C_\xi^T G_3 C_\xi \\ &\quad - \frac{1}{4} C^T G_4 C) \hat{x} - \hat{\nu}^T (D^T + D - \frac{1}{4} G_2) \hat{\nu} + 2e_I^T K_I C_1 e_I \end{aligned}$$

Since $z_1 - e_I + K_I e_I$, equation (30) can be shown

$$\begin{aligned} \dot{V} &= -z_1^T C_1 z_1 - z_2^T C_2 z_2 - \hat{\nu}^T (D^T + D) \hat{\nu} - \hat{x}^T Q \hat{x} \\ &\quad + 2e_I^T K_I C_1 e_I \\ &= -\dot{e}_I C_1 \dot{e}_I - e_I^T K_I^T C_1 K_I e_I - z_2^T C_2 z_2 - \hat{x}^T Q \hat{x} \\ &\quad - \hat{\nu}^T (D^T + D) \hat{\nu} \\ &\leq 0 \end{aligned} \quad (34)$$

implying that the closed-loop system is globally uniformly stable (GUS). As proved in (Aarset et al., 1998), the controller can be proven to be globally exponentially stable (GES) when integral action is implemented through the feedback cancellation of the bias estimates only. The entire system including the observer and the controller structure is shown in Fig. 3.

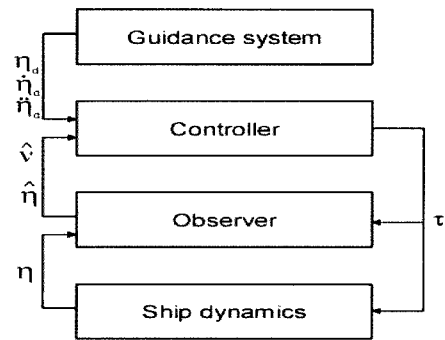

Fig. 3 The observer and controller system

5. Simulation Results

The developed nonlinear observer and controller are applied to a model of DP ship in three degrees of freedom, and the simulation results are shown in this section. The ship parameters and the controller and observer parameters used in the simulation study can be found in (Kim and

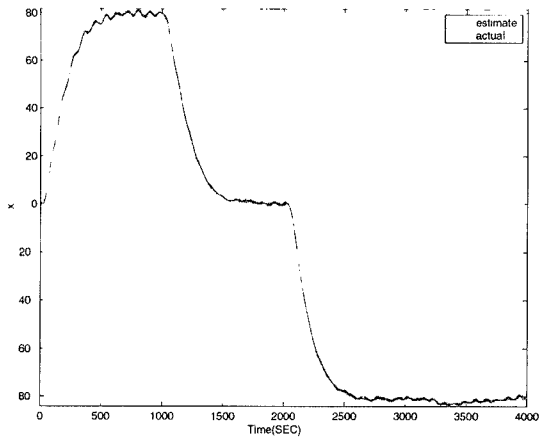

Fig. 4 Actual (dotted) and estimated (solid) X position of the DP ship

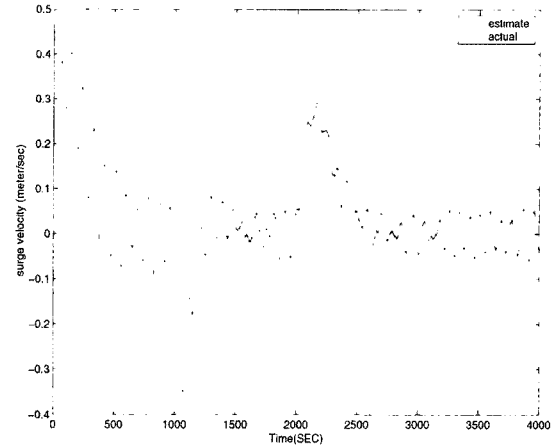

Fig. 6 Actual (solid) and estimated (dotted) surge velocity of the DP ship

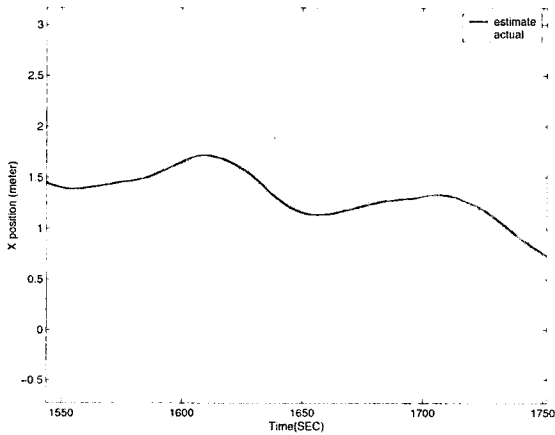

Fig. 5 Zoom-in of the measured and estimated X position

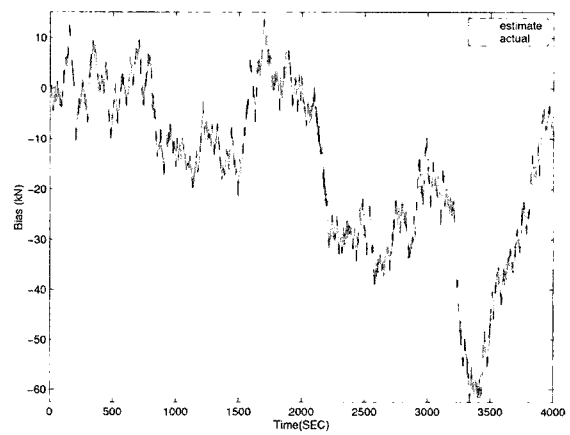

Fig. 7 Estimated bias in surge direction

Inman, 2000). In the simulation, the measurement noise is modelled as Gaussian white noise, and the simulation time step was 0.1 sec. The ship was commanded to follow a specified trajectory at low speed. The X position of the ship is presented in Fig. 4. The dotted line represents the actual position of the ship, and the solid line represents the estimate of the X position. As it can be seen, the estimated value from the observer converges to the actual value in short time. A zoom-in of the part of the X position is shown in Fig. 5 to verify the wave filtering performance of the observer. Again the dotted line is the actual state and the solid line is the estimate, and the low frequency estimate is successfully obtained. Feeding back this low frequency estimate to the controller prevents excessive wear of the actuator and fuel consumption as discussed in the previous section. In Fig. 6, the estimate of the surge velocity is shown, and an excellent linear velocity estimate is clearly seen. The bias estimate is illustrated in Fig. 7, and this bias estimate can be used as a feedforward control action. Finally, the X and Y position tracking performance of the DP ship is shown in Fig. 8. The solid line represents the

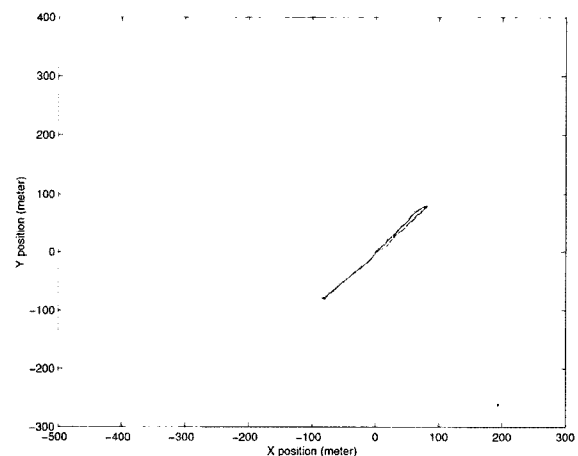

Fig. 8 Comparison of X, Y position tracking of the DP ship with the proposed observer (solid) and the conventional observer (dotted)

tracking performance of the controller with the proposed observer, and an excellent tracking performance can be seen. The dotted line represents the tracking performance using

the same controller but the observer without the discontinuous term, and as shown, the ship fails to follow the commanded position and drifts away. This demonstrates the robustness of the proposed observer.

4. Conclusion

In this study, a robust nonlinear observer is derived for dynamic positioning of ships. This nonlinear observer has a special structure with a discontinuous term. In particular, the nonlinear observer has a desirable robustness feature against modeling errors and disturbances. The nonlinear observer provides estimates of linear velocities and bias of ships, and it also provides filtering of high frequency wave frequency motion. No linearization of the kinematic equation is necessary using the nonlinear observer resulting in a fewer number of tuning parameters compared to that of the Kalman filter. An output feedback controller is derived using the back stepping technique based on the proposed observer. With the given nonlinear observer, backstepping is applied to a new system, in which the equations of unmeasured states have been replaced by the corresponding equations of their estimates from the observer. At each step of the procedure, observation errors are treated as disturbances and accounted for using nonlinear damping. This improved nonlinear observer technique in combination with advanced nonlinear control techniques will provide better performance of dynamic positioning of ship in real sea environment.

References

- Aarset, M.F., Strand, J.P. and Fossen T.I. (1998). "Nonlinear Vectorial Observer Backstepping with Integral Action and Wave Filtering for Ships", Proc. of the IFAC Conference on Control Application in Marine Systems (CAMS'98), Fukuoka, Japan, pp 83-89.
- Berghuis, H. and Nijmeijer, H. (1993). "A Passivity Approach to Controller-observer Design for Robots", IEEE Transactions on robotics and automation, Vol 8, No 6, pp 740-754.
- Fossen, T.I. (1994). *Guidance and Control of Ocean Vehicles*, John Wiley and Sons, New York.
- Fossen, T.I. and Strand, J.P. (1999). "Passive Nonlinear Observer Design for Ships using Lyapunov Methods", *Automatica*, Vol 35, No 1, pp 3-16.
- Khalil, H.K. (1996). *Nonlinear Systems*, Prentice Hall Inc., New Jersey.
- Kim, M.H. and Inman, D.J. (2001). "Application of a Sliding Mode Observer for Dynamic Positioning of Ships", Proc. ASME Design and Engineering Technical Conferences, Pittsburgh, Pennsylvania, pp VIB 21602.
- Misawa, E.A. (1988). "Nonlinear State Estimation using Sliding Observers", Ph.D. Thesis, Massachusetts Institute of Technology.
- Nicosia, S. and Tomei, P. (1990). "Robot Control by using only Joint Position Measurements", IEEE Transactions on automatic control, Vol 35, pp 1058-1061.
- Slotine, J.J., Hedrick, J.K. and Misawa, E.A. (1987). "On Sliding Mode Observers for Nonlinear Systems", *Journal of Dynamic Systems, Measurement and Control*, Vol 109, pp 242-252.

Appendix

For the computer simulation, the following parameters were used.

$$M = \begin{bmatrix} 5.3122e6 & 0 & 0 \\ 0 & 8.2831e6 & 0 \\ 0 & 0 & 3.7454e9 \end{bmatrix} \quad (A.1)$$

$$D = \begin{bmatrix} 5.0242e4 & 0 & 0 \\ 0 & 2.7229e5 & -4.3933e6 \\ 0 & -4.3933e6 & 4.1894e8 \end{bmatrix}$$

The values for the bias time constants were selected as

$$T = \begin{bmatrix} 1000 & 0 & 0 \\ 0 & 1000 & 0 \\ 0 & 0 & 10000 \end{bmatrix} \quad (A.2)$$

and the dominant wave frequencies and the damping coefficients were

$$\omega_{oi} = 0.8976, \zeta_i = 0.1 \quad (A.3)$$

corresponding to a wave period of 7.0 (s) in surge, sway and yaw. The notch filter parameters were chosen as $\zeta_{ni} = 1.0$ and $\omega_{ci} = 1.1$.

The values for the controller gains were

$$H_1 = \begin{bmatrix} -2.2059 & 0 & 0 \\ 0 & -2.2059 & 0 \\ 0 & 0 & -2.2059 \\ 1.6157 & 0 & 0 \\ 0 & 1.6157 & 0 \\ 0 & 0 & 1.6157 \end{bmatrix}$$

$$H_2 = \begin{bmatrix} 1.1 & 0 & 0 \\ 0 & 1.1 & 0 \\ 0 & 0 & 1.1 \end{bmatrix}, H_3 = 1e6 \times \begin{bmatrix} 0.1 & 0 & 0 \\ 0 & 0.1 & 0 \\ 0 & 0 & 100 \end{bmatrix}$$

$$H_4 = 1e5 \times \begin{bmatrix} 0.1 & 0 & 0 \\ 0 & 0.1 & 0 \\ 0 & 0 & 100 \end{bmatrix} \quad (A.4)$$

$$K_I = \begin{bmatrix} 100 & 0 & 0 \\ 0 & 100 & 0 \\ 0 & 0 & 100 \end{bmatrix}, \bar{K} = \begin{bmatrix} 10 & 0 & 0 \\ 0 & 10 & 0 \\ 0 & 0 & 0.01 \end{bmatrix}$$

and the values for the observer gains were chosen as

$$C_1 = \begin{bmatrix} 0.1 & 0 & 0 \\ 0 & 0.1 & 0 \\ 0 & 0 & 0.1 \end{bmatrix}, C_2 = \begin{bmatrix} 0.1 & 0 & 0 \\ 0 & 0.1 & 0 \\ 0 & 0 & 0.1 \end{bmatrix} \quad (A.5)$$

$$d_1 = 10, d_2 = 10, d_3 = 1, d_4 = 1, d_5 = 1, d_6 = 1$$

2002년 6월 18일 원고 접수

2002년 7월 8일 최종 수정본 채택