

Novel Modular 3-phase AC-DC Flyback Converter for Telecommunication

¹Ju-Yeop Choi*, ²Jong-Pil Lee, ³Taek-Yong Kim, ⁴Joong-Ho Song, and ⁴Ick Choy

¹Dept. of Electrical Engineering, Kwangwoon University, Seoul, Korea

²Hyundai Heavy Industries Co., Korea, ³Jeon-Sung Electric, Korea

⁴Intelligent System Control Research Center, Korea Institute of Science and Technology, Korea

ABSTRACT

A novel mode of parallel operation of a modular 3-phase AC-DC flyback converter for power factor correction along with tight regulation was recently analyzed and presented. The advantage of the proposed converter does not require expensive high voltage and high current devices that are normally needed in popular boost type 3-phase converter. In this paper the detailed small signal analysis of the modular 3-phase AC-DC flyback converter is provided for control purposes and also experimental results are included to confirm the validity of the analysis.

Keywords: 3-phase AC-DC flyback converter, modeling, parallel operation, telecommunication

1. Introduction

Three-phase AC-DC power converters are becoming popular for high voltage/high power applications such as telecommunications. They often require input/output transformer isolation for safety, a unity input power factor for minimum reactive power, free input harmonic currents fed back to the AC power distribution system, and, finally, high efficiency and high power density for minimum weight and volume. In recent years many researches have been focused on achieving the issues mentioned above and quite satisfactory improvements have been published so far^[1,2,3]. However, in view point of commercial use, digital control implementation of 3-phase switching power

converters is still more complicated and expensive than analog control implementation in spite of its outstanding performance. Among various topologies, the boost-type PFC, which consists of a diode rectifier followed by a boost-converter is most popular because the inductor in the converter carries continuous current and the filtering effort for the input current is thus minimal. Boost-type single-phase converter normally converts a 50Hz or 60Hz AC voltage into a DC voltage of 400V. For Telecom and navigation equipment, usually a high frequency (typically 100KHz) second stage DC-DC power MOSFET converter is used to change to 400V to 48V of Fig. 1.

However, there is an increasing demand in the world power supply market to develop high-power power supplies (12KW-15KW or higher) with power factor correction. Existing high-power PFC approach uses a 3-phase boost-type switched mode rectifier as a first-stage converter to achieve AC-DC power conversion with a typical DC output voltage of 800V of Fig. 2.

Manuscript received March 4, 2002; revised July 8, 2002.

Corresponding Author: juyeop@daisy.gwu.ac.kr, Tel: +82-2-940-5143, Fax: +82-2-943-7195

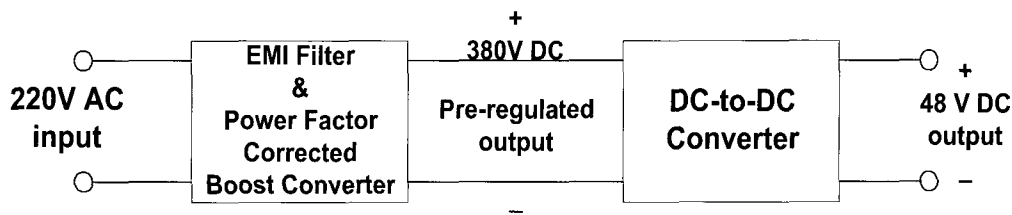

Fig. 1. Single-phase 220V two-stage AC-DC converter.

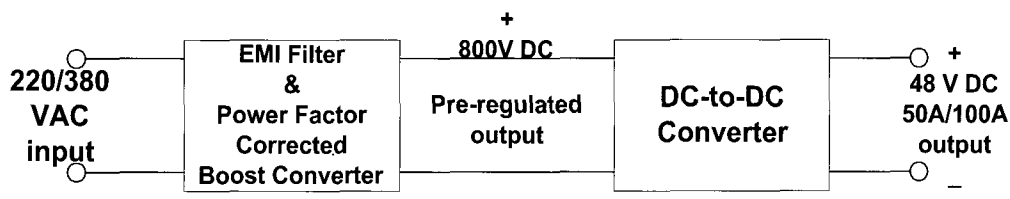

Fig. 2. Three-phase 380V two-stage AC-DC converter.

A second-stage DC-DC converter then converts the 800V to 48V. This 800V DC link voltage exceeds the maximum voltage ratings of many high current, high frequency power MOSFETs. The major problems of existing boost-type schemes include the redundancy in the two-stage arrangement and the high intermediate DC voltage (800V) for three-phase AC-DC converter. The high DC voltage means that high performance MOSFETs cannot be used in the second-stage and that inferior (in terms of switching speed, on-stage voltage drop and conducting loss) and expensive power switches like IGBTs have to be used. The two-stage operation would lead to increased switching loss, reduced efficiency, increased size and cost of magnetic and filtering and heatsink components and reduced dynamic performance.

The industry-preferred approach favors the paralleling of single-phase converter units to form high-power converter systems. Such modular development approach has the following advantages:

- well proven and reliable single-phase converter technology can be used immediately,
- no major change of existing production line is required,
- power expansibility offers great flexibility in the development of power converter products for different power levels,
- less requirements for maintenance and repair of power

converter modules because of the use of standard single-phase converter units,

- standard single-phase converter units do not require high-voltage devices that are normally needed in specially designed three-phase converters.

The proposed parallel operation of a modular 3-phase AC-DC flyback converter for power factor correction has a similar topology to the novel Delco switch-mode-rectifier employing three separate identical single-phase AC-DC converters for each of 3-phase source with the dc output connected in parallel. However, compared with compatible converters for 1-phase and 3-phase^[4, 5], the proposed converter shows a fairly good improvement in reducing manufacturing costs due to using one PWM control chip. Furthermore, the proposed scheme offers not only flexibility in either 3-phase 3-wired system or 3-phase 4-wired system but also simpler design, easier testing and higher reliability thanks to the three identical standardized modules. But disadvantages are higher power semiconductor devices and pulsating power flow compared with 3-phase system, which are common to all Delco type of converters. However, since lower rated voltage and current switching devices can be used in each 1-phase, which are cheaper than higher rated ones in 3-phase, a drastic cost reduction was achieved to offset the increased number of semiconductor components in the proposed topology.

Furthermore, the converters described here can be used for either 1-phase or 3-phase with and without the neutral depending on the condition of ac source. The overall schematic diagram of the proposed converter is shown in Fig. 3. The proposed each 1-phase AC-DC converter consists of a 1-phase diode rectifier, a high frequency filter placed on the DC side of the bridge rectifier and an energy storage inductor with step-down ability along with input/output isolation, and a dc-link filter capacitor.

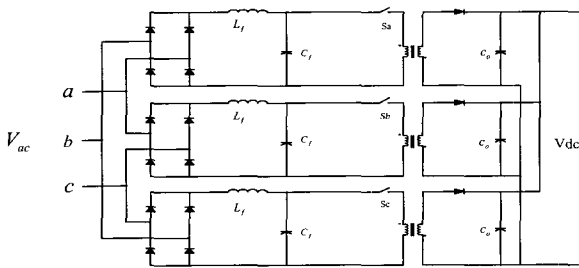

Fig. 3. Overall Schematic Diagram of the Proposed Converter.

2. Modeling and Small Signal Analysis of 3-phase AC-DC Flyback Converter

In order to implement a stable closed-loop control for a possibly unstable modular flyback system, the incremental dynamics of the proposed system must be clarified. The modeling and small signal analysis of 3-phase AC-DC flyback converter without a high frequency filter placed on the DC side of the bridge rectifier is shown [6] and the control-to-output voltage transfer function can be shown as following form:

$$T_p(s) \cong \frac{R_0(|v_a| + |v_b| + |v_c|)}{s^2(R_0 C_e L) + s(L + R_L R_0 C_e) + (R_L + 3R_0)}$$

where, $R_L \cong -rL$, $L - 2rRC_e L \cong L + R_L R_0 C_e$,
 $r^2 RC_e L - rL + 3d'R \cong R_L + 3R_0$

In the above equations C_e is $3C_o$ and r is the almost negligible value of the equivalent winding resistance including the primary and secondary circuits. The

configuration requires that three switches in the three identical converter modules must be switched simultaneously for proper operation. The switching action in each module is controlled in such a way that the input line current is shaped into a sinusoidal waveform and is in phase with three corresponding phase voltage, thus producing almost unity factor. In this topology [6], due to the pulsating diode current, low pass filter consisting of inductors and capacitors is connected before the diode bridge rectifier.

The proposed basic single converter module is shown in Fig. 4 and the system equations to develop the transfer functions are listed in Table 1.

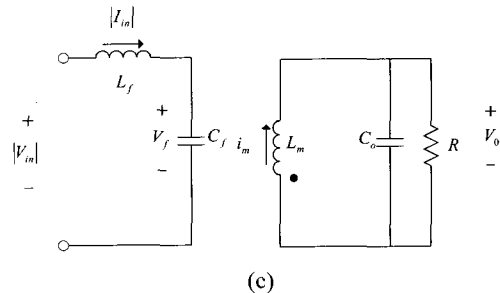
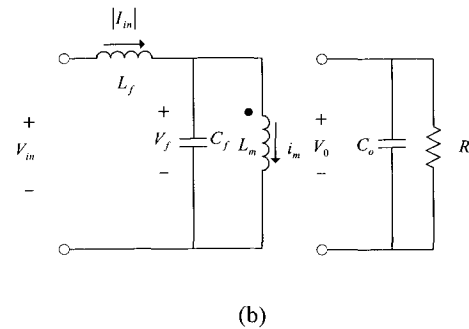
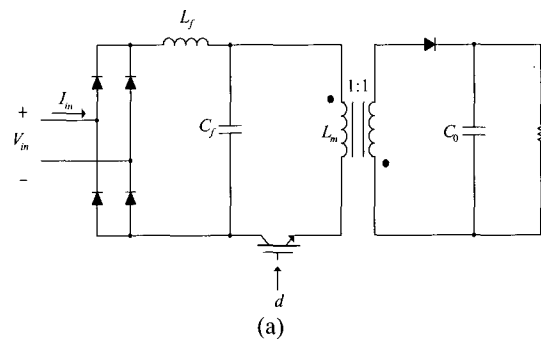

Fig. 4. (a) A Single Module Flyback Converter, (b) Circuit Topology during On Time, (c) Circuit Topology during Off Time.

Table 1. The Modeling of 3 Modular Flyback Converter.

Step 1: state-variable description for each circuit state

• switch on state

$$\dot{i}_{in} = \frac{1}{L_f} [v_{in} - v_f], \quad \dot{v}_f = \frac{1}{C_f} [i_{in} - i_m],$$

$$\dot{i}_m = \frac{1}{L_m} v_f, \quad \dot{v}_0 = -\frac{1}{RC_e} v_f$$

• switch off state

$$\dot{i}_{in} = \frac{1}{L_f} [v_{in} - v_f], \quad \dot{v}_f = \frac{1}{C_f} i_m, \quad \dot{i}_m = -\frac{1}{L_m} v_0$$

$$\dot{v}_0 = \frac{3}{C_e} i_m - \frac{1}{RC_e} v_0$$

Step 2: state-space average

$$\dot{i}_{in} = \frac{1}{L_f} [v_{in} - v_f], \quad \dot{v}_f = \frac{1}{C_f} [i_{in} - di_m]$$

$$\dot{i}_m = \frac{1}{L_m} [dv_f - (1-d)v_0], \quad \dot{v}_0 = \frac{3}{C_e} (1-d)i_m - \frac{1}{RC_e} v_0$$

Step 3: ac perturbation and linearization

$$\hat{i}_{in} = I_{in} + \hat{i}_{in}, \quad v_f = V_f + \hat{v}_f, \quad \hat{i}_m = I_m + \hat{i}_m,$$

$$v_0 = V_0 + \hat{v}_0, \quad d = D + \hat{d}$$

$$\dot{\hat{i}}_{in} = \frac{1}{L_f} [V_{in} - V_f - \hat{v}_f] = -\frac{\hat{v}_f}{L_f},$$

$$\dot{\hat{v}}_f = \frac{1}{C_f} [\hat{i}_{in} - (D + \hat{d})(I_m + \hat{i}_m)] = \frac{1}{C_f} [\hat{i}_{in} - D\hat{i}_m - \hat{d}I_m]$$

$$\dot{\hat{i}}_m = \frac{1}{L_m} [(D + \hat{d})(V_f + \hat{v}_f) - (1 - D - \hat{d})(V_0 + \hat{v}_0)]$$

$$= \frac{1}{L_m} (D\hat{v}_f + (V_f + V_0)\hat{d} - (1 - D)\hat{v}_0)$$

$$\dot{\hat{v}}_0 = \frac{-1}{RC_e} (V_0 + \hat{v}_0) + \frac{3}{C_e} (1 - D - \hat{d})(I_m + \hat{i}_m)$$

$$= \frac{-1}{RC_e} \hat{v}_0 + \frac{3}{C_e} (\hat{i}_m - D\hat{i}_m - I_m\hat{d})$$

Step 4: frequency domain representation

$$s\hat{i}_{in}(s) = -\frac{\hat{v}_f(s)}{L_f}, \quad s\hat{v}_f(s) = \frac{1}{C_f} [\hat{i}_{in}(s) - D\hat{i}_m(s) - \hat{d}(s)I_m]$$

$$s\hat{i}_m(s) = \frac{1}{L_m} [D\hat{v}_f(s) + (V_f + V_0)\hat{d}(s) - (1 - D)\hat{v}_0(s)]$$

Step 5: control to output

$$(s)\hat{v}_0(s) = \frac{-1}{RC_e} \hat{v}_0(s) + \frac{3}{C_e} (\hat{i}_m(s) - D\hat{i}_m(s) - I_m\hat{d}(s))$$

voltage transfer function (see Eq. (1))

 where, $D = \frac{V_0}{V_0 + v_{in}}$, $I_m = \frac{I_{in}}{D}$, $V_f = v_{in} = |v_a| + |v_b| + |v_c|$

For designing voltage loop controller open-loop bode plots of Dr. Hui's system^[6] and given system ($V_{in} = 380\text{VAC}$, $V_{out} = 48\text{VDC}$) are shown in Fig. 5(a), (b), respectively, based on the following circuit parameters: $L_m = 500\mu\text{H}$, $C_o = 1700\mu\text{F}$, $L_f = 2.4\text{mH}$, $C_f = 1\mu\text{F}$, $R = 5\Omega$.

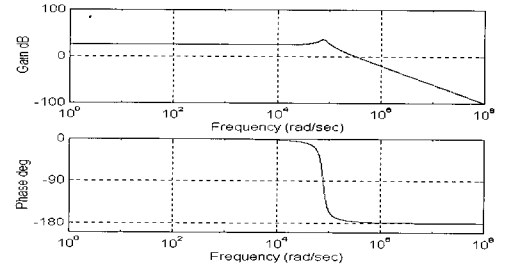

(a)

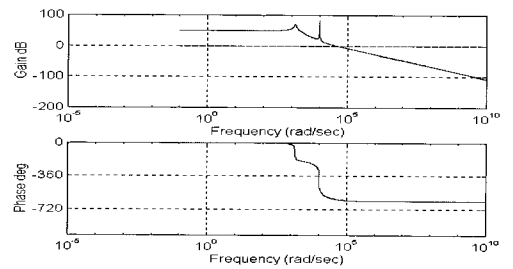

(b)

Fig. 5. Bode Plot of the Open-Loop System; (a) Hui's system, (b) Proposed System.

$$\therefore \frac{v_0(s)}{d(s)} = \frac{3R[s^3(-I_m L_m C_f L_f) + s^2(1-D)(V_f + V_0)L_f C_f + s(-(1-D)D I_m L_f - I_m L_m - I_m D^2 L_f) + (1-D)(V_f + V_0)]}{s^4(RC_e L_m C_f L_f) + s^3 L_m C_f L_f + s^2(RC_e(L_m + D^2 L_f) + 3R(1-D)^2 C_f L_f) + s(L_m + D^2 L_f) + 3R(1-D)^2} \quad (1)$$

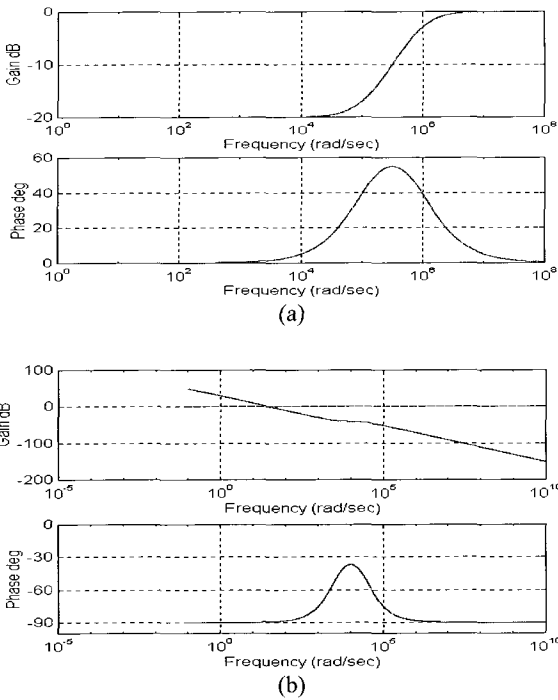

Fig. 6. (a) Lead Compensator for the Hui's System, (b) 2-pole 1-zero Compensator for the Proposed System.

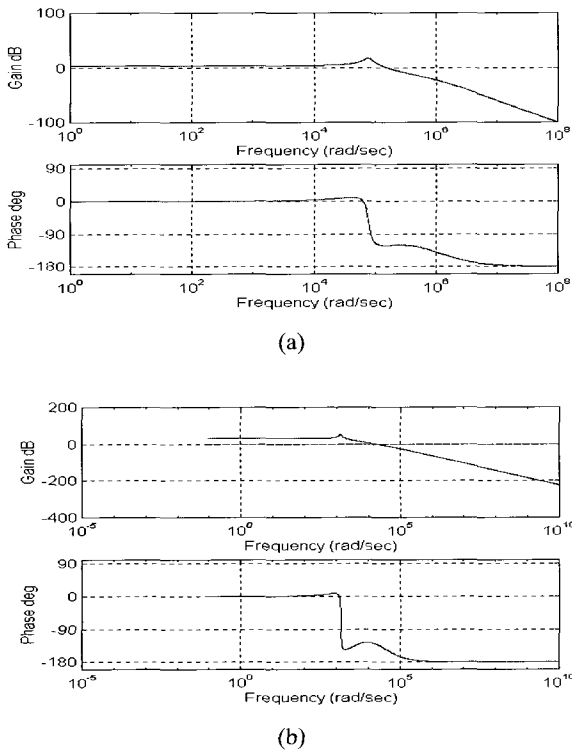

Fig. 7. Bode Plot of the Closed-Loop System; (a) Hui's system, (b) Proposed System.

To compensate phase margin of both systems, each different compensator of Fig. 6(a), (b) is designed properly, providing 58° and 47° of phase margin shown in Fig. 7(a), (b), correspondingly.

3. PSpice Simulation and Implementation of 3-phase AC-DC Flyback Converter

Recently, newly developed special ICs lower the cost of the switch-mode power supply circuits. The Unitrode 3825 is the one of resulting ICs, which is designed to optimally facilitate a PWM controller using voltage mode and current mode control. The average PSpice model of flyback converter is more effective to simulate a few line cycle without time convergence error for verification of power factor correction circuits. Figures 8, 9, 10 and 11 show a schematic, a detailed diagram of the UC3825, a schematic of 3-phase 3-wired and 3-phase 4-wired given flyback converter system using PSpice.

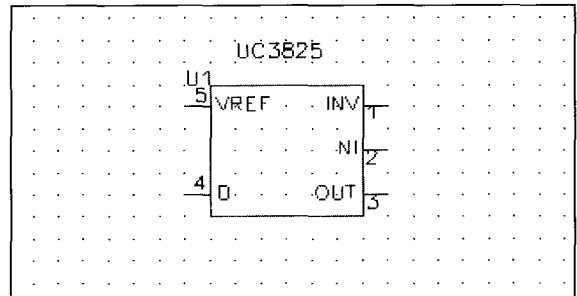

Fig. 8. PSpice Model of UC3825.

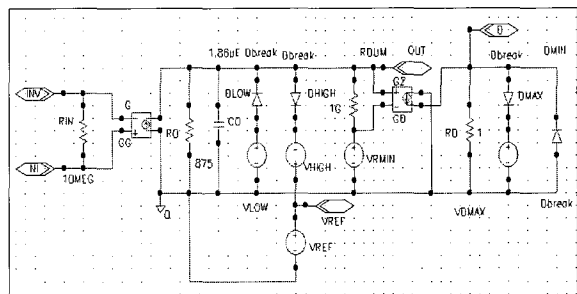

Fig. 9. Equivalent Circuit of UC3825.

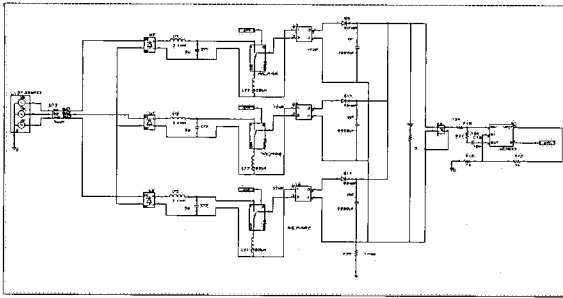

Fig. 10. A Schematic of the Modular 3-wired AC-DC Flyback Converter.

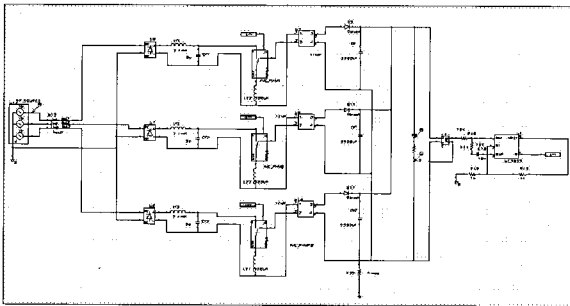
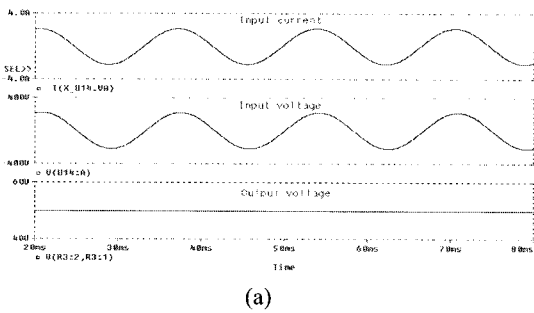
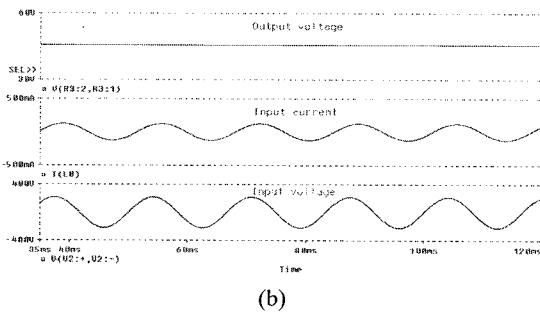

Fig. 11. A Schematic of the Modular 4-wired AC-DC Flyback Converter.



(a)



(b)

Fig. 12. Waveform of the Modular 3-wired AC-DC Flyback Converter; (a) Hui's system, (b) Proposed System.

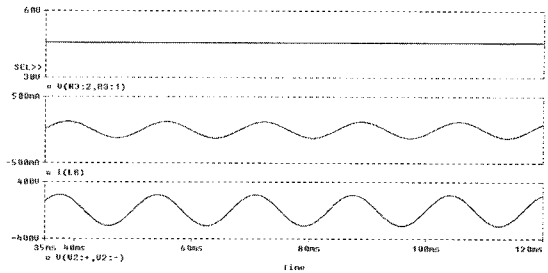

(a)

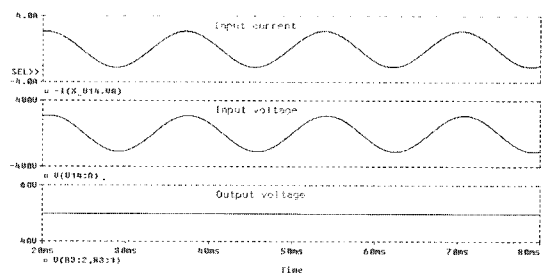

(b)

Fig. 13. Waveform of the Modular 4-wired AC-DC Flyback Converter; (a) Hui's system, (b) Proposed System.

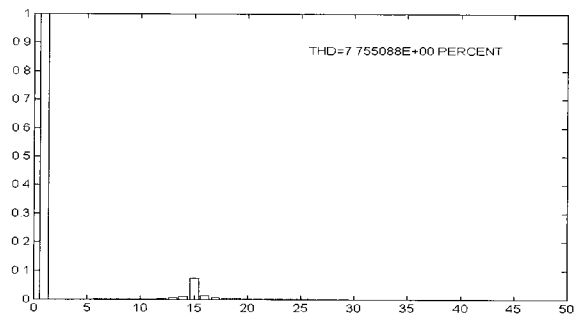

Fig. 14. Harmonic Spectrum of the Input Phase Current in the 3-wired Hui's Flyback Converter.

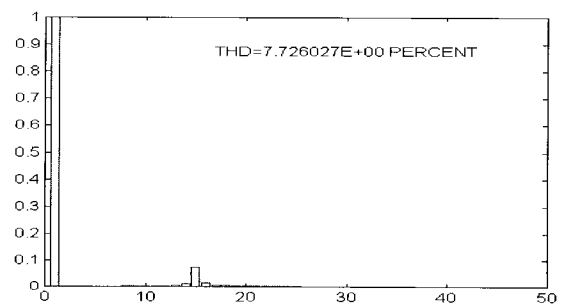

Fig. 15. Harmonic Spectrum of the Input Phase Current in the 4-wired Hui's Flyback Converter.

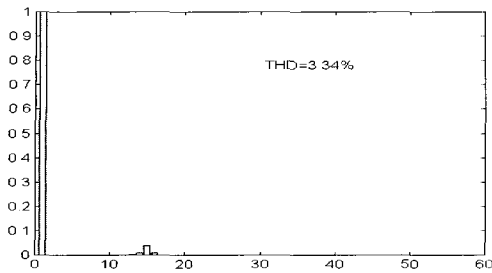

Fig. 16. Harmonic Spectrum of the Input Phase Current in the 3-wired Proposed Converter.

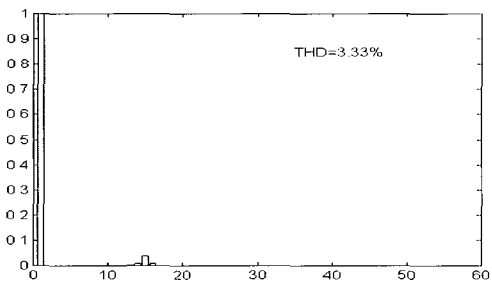

Fig. 17. Harmonic Spectrum of the Input Phase Current in the 4-wired Proposed Converter.

Based on each schematic of 3-wired and 4-wired system, output voltage, input current and input voltage waveforms are shown Fig. 12 and 13, correspondingly. Figures 14, 15, 16 and 17 compare the spectra of simulated input current which show almost the same amount of the harmonic contents in the 3-wired and 4-wired system at each type of converter.

Owing to the close modeling of the proposed system, harmonic contents in both 3-wired and 4-wired system were reduced to the amount of less than half compared with those of the Hui's system. Experiments were completed for both cases and Figs. 18 and 19 show the line-to neutral input voltage, current waveforms and DC output voltage of the 3-phase 3-wired system, respectively. Nearly sinusoidal input current is shown providing high power factor. At full load, the total current harmonics of the 3-phase 3-wired connection is 6.0%, which is somewhat larger than those of simulated case, 3.34%. This could be due to variations of power circuits and control parameters of each individual module. However, the line-to neutral input voltage, current waveforms of the 3-phase 4 wired system shown in Fig. 19 is exactly in phase with

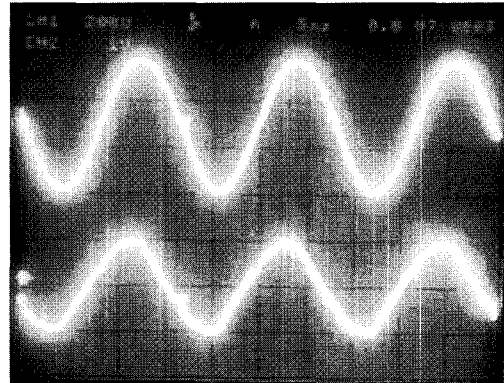

Fig. 18. 3-Phase Connection (3wire); upper: v_{an} , lower: i_{an} , sweep: 5ms/div, THD: 6.0%.

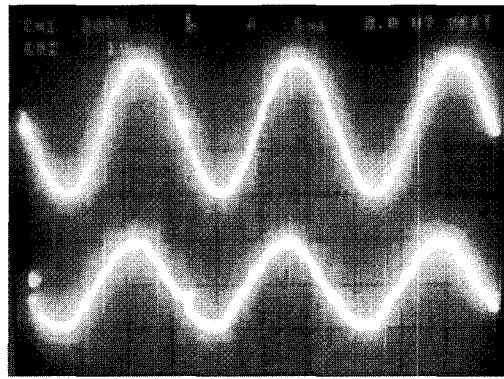

Fig. 19. 3-Phase Connection (4Wire); upper: v_{an} , lower: v_{out} , sweep: 5ms/div, THD: 4.8%.

the corresponding input voltage and the resulting power factor is 0.99, showing the advantages of the proposed topology.

4. Conclusions

This paper addresses the analysis and design of a modular 3-phase AC-DC flyback converter, which draws high quality input current waveforms along with 3-phase 3-wired input/3-phase 4-wired input compatibility. The experimental results of the proposed converter provide an excellent power factor along with drastic cost reduction. Three individual 1-phase 1 kw AC-DC power modules operating at 100 khz were constructed for telecommunication applications to verify the validity of the modeling and analysis of the proposed system.

Acknowledgements

This work was supported by grant No. (R01-2001-00313) from the Korea Science & Engineering Foundation.

References

- [1] A. Busse and J. Holtz, "Multiloop control of a unity power factor fast switching ac to dc converter", Proc. of IEEE PESC, pp. 171~179, 1982.
- [2] L. Malesani and P. Tenti, "Three-phase ac/dc PWM converter with sinusoidal input currents and minimum filter requirements", IEEE Trans. Ind. Appl., vol. IA-23, no. 1, pp. 71~77, 1987.
- [3] V. Vlatkovich and D. Boroyevish, "Digital-signal-processor-based control of three-phase, space vector modulated converters", IEEE Trans. Ind. Electron., vol. IE-41, no. 3, pp. 148~157, 1995.
- [4] M.J. Kocher and R.L. Steigerwald, "An AC to DC converter with high quality input waveforms", IEEE Trans. Power Electronics, pp. 63~75, 1982.
- [5] J.Y. Choi, H.S. Mok, and T.Y. Kim, "A Single-Phase/Three-Phase Compatible Soft-Switched AC-to-DC Converter", Proc. of Seventh European Conference on Power Electronics and Applications, pp. 464~469, Nov. 1997.
- [6] S.Y.R. Hui and H. Chung, "Paralleling power converters for AC-DC step-down power conversion with inherent power factor correction", Proc. of Seventh European Conference on Power Electronics and Applications, pp. 182~187, Nov. 1997.

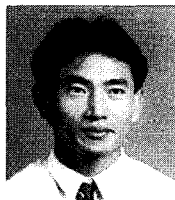

Ju-Yeop Choi received the B.S. degree from EE of Seoul National University, Korea in 1983 and the M.S. degree 1988 from EE of Univ. of Texas at Arlington, USA and the Ph.D. degree from EE of Virginia Tech, USA, in 1994. He worked as an engineer in E-hwa Electrical Co., Korea from 1983 to 1988. He had been with the Intelligent System Control Research Center, Korea Institute of Science and Technology from 1995-2000. Since 2000 he has been an assistant professor for EE of Kwangwoon Univ. His primary research interests are in switching converter, soft switching, and photovoltaic systems.

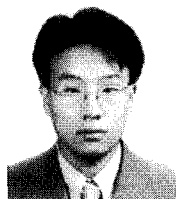

Jong-Pil Lee received the B.S. and M.S. degrees from Korea University, Korea in 1997 and 1999. Also, he had been with the Intelligent System Control Research Center Korea Institute of Science and Technology from 1997 to 1999 as a student researcher. Since 1999, he works for Hyundai Heavy Industries as a researcher. His primary research interests are in switching converter technologies.



Taek-Yong Kim received the B.S. from Inha University, Korea in 1981. He worked as an engineer in E-hwa Electrical Co., Korea from 1981 to 1986. Since 1986, he has been with Jeon-Sung Electric as a chief engineer and president. His primary research interests are in switching converter, UPS and rectifier for telecommunication.



Joong-Ho Song received the B.S. and M.S. degrees from Seoul National University, Korea in 1980 and 1982, and the Ph.D. degree from KAIST, Korea, in 1993. He worked as an engineer in E-hwa Electrical Co., Korea from 1982 to 1985. Since 1985, he has been with the Intelligent System Control Research Center, Korea Institute of Science and Technology. He was a visiting scholar in the WEMPEC, University of Wisconsin-Madison in 1995-1996. His primary research interests are in switching converter, electric machine drives, and servo control technologies

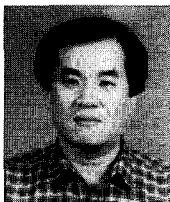

Ick Choy received the B.S., M.S., and Ph.D. degrees from Seoul National University, Korea, in 1979, 1981, and 1990, respectively. Since 1981, he has been with the Intelligent System Control Research Center, Korea Institute of Science and Technology. His main research interests include microprocessor applications, high-performance drives, and emerging technologies.