

## Heat Transfer Enhancement for Fin-Tube Heat Exchanger Using Vortex Generators

**Seong-Yeon Yoo\***, **Dong-Seong Park**, **Min-Ho Chung**

*Department of Mechanical Design Engineering, Chungnam National University, Taejon 305-715, Korea*

**Sang-Yun Lee**

*Department of Computer Aided Design, Daeduk College, Taejon 305-715, Korea*

Vortex generators are fabricated on the fin surface of a fin-tube heat exchanger to augment the convective heat transfer. In addition to horseshoe vortices formed naturally around the tube of the fin-tube heat exchanger, longitudinal vortices are artificially created on the fin surface by vortex generators. The purpose of this study is to investigate the local heat transfer phenomena in the fin-tube heat exchangers with and without vortex generators, and to evaluate the effect of vortices on the heat transfer enhancement. Naphthalene sublimation technique is employed to measure local mass transfer coefficients, then analogy equation between heat and mass transfer is used to calculate heat transfer coefficients. Experiments are performed for the model of fin-circular tube heat exchangers with and without vortex generators, and of fin-flat tube heat exchangers with and without vortex generators. Average heat transfer coefficients of fin-flat tube heat exchanger without vortex generator are much lower than those of fin-circular tube heat exchanger. On the other hand, fin-flat tube heat exchanger with vortex generators has much higher heat transfer value than conventional fin-circular tube heat exchanger. At the same time, pressure losses for four types of heat exchanger is measured and compared.

**Key Words :** Heat Exchanger, Vortex Generator, Heat Transfer Enhancement, Naphthalene Sublimation Technique

### 1. Introduction

For energy conservation and the protection of environment, it becomes increasingly important to adopt heat transfer enhancement technique in the design of heat exchangers used in process industries for heating, cooling, air-conditioning and refrigeration. There are two enhancement technologies of convective heat transfer for compact heat exchangers. One is to extend heat transfer surface area like a fin, the other is to increase heat transfer coefficients between solid

surface and fluid. Vortex generator is the one that can be used for heat transfer enhancement in fin-tube and plate-fin heat exchangers. Fiebig and Chen(1998) have summarized their systematic study on the characteristics of heat transfer surface with vortex generators. According to their research, the fin heat exchanger surface may be reduced with vortex generators by more than 50 % compared to a plain fin for identical heat duty and pressure loss. Zhu et al. (1995) have studied numerically the effect of vortex generator on the flow and heat transfer in a rib-roughened channel. Yoo(1997) have developed fin-flat tube heat exchanger with vortex generators, and showed that vortex generators increase heat transfer rates on the fin surface almost twice.

When the heat is transferred by forced convection from fin-tube heat exchanger with vortex generators, complex flow phenomena

---

\* Corresponding Author,

**E-mail :** syyoo@cnu.ac.kr

**TEL :** +82-42-821-6646; **FAX :** +82-42-822-7366

Department of Mechanical Design Engineering,  
Chungnam National University, Taejon 305-764,  
Korea. (Manuscript **Received** April 30, 2001; **Revised**  
October 8, 2001)

– such as stagnation, separation, vortex formation or wake – affect the heat transfer characteristics. In a complicated flow situation, it is very difficult to measure local heat transfer coefficients by conventional methods of heat transfer measurement. Goldstein et al. (1990) showed that mass transfer experiments using naphthalene sublimation technique is the effective way for measuring the local heat transfer distribution in a complex, three-dimensional flow region. In the present study, naphthalene sublimation technique is employed to measure local mass transfer from fin-tube heat exchanger with vortex generators. Then, mass transfer data are converted to their counterpart of heat transfer process using heat/mass transfer analogy. Automated sublimation depth measurement system is used to measure the distribution of local mass transfer.

The purpose of this study is to investigate the effect of vortex generators on heat transfer enhancement of fin-tube heat exchangers. Experiments are performed for the fin-circular tube heat exchanger and the fin-flat tube heat exchanger with and without vortex generators, respectively. At the same time, friction loss for four types of heat exchanger is also measured and compared.

## 2. Experimental Apparatus and Procedure

### 2.1 Experimental apparatus

The experimental apparatus comprises a wind tunnel, a naphthalene casting facility and a sublimation depth measurement system. The open-circuit blowing type wind tunnel, which has square test section of 300 mm × 46 mm, is used. The air speed is controlled by inverter and the freestream turbulence intensity is less than 1.0 % over the entire range of speed.

The naphthalene casting facility has the mold, heating plate, hot air gun, mold separating device and suction hood. Automated sublimation depth measurement system is used to measure local mass transfer coefficient. The depth measurement system consists of a depth gage, a signal conditioner, two stepper motor-driven traversing table, a data

acquisition board and a personal computer. The depth gage used to measure the naphthalene surface profile is a linear variable differential transformer (LVDT) which has ±0.254 mm (0.01 in) linear range and ±25.4 nm (1 μ-in) resolution. It is connected to a signal conditioner, which supplies excitation voltage to LVDT and amplifies the output signal from LVDT.

### 2.2 Experimental procedure

A new naphthalene casting is made for each test run. The testpiece is clamped to a highly polished mold, and molten naphthalene is then poured into the mold. After the naphthalene solidifies, the mold is separated from the testpiece by applying a shear force. The cast testpiece is placed and clamped on the sublimation depth measurement table. Initial readings of the naphthalene surface elevation are taken at predetermined locations using the automated sublimation depth measurement system. The testpiece is then installed in the wind tunnel and exposed to the air stream for about one hour. During a test run, the naphthalene surface temperature, tunnel air temperature and pressure, and freestream velocity are measured. The testpiece is then removed and a second set of surface elevation is obtained at the same locations as before. Finally, data reduction program calculates Sherwood numbers and Nusselt numbers from the measured sublimation depth and other related data.

### 2.3 Data reduction

The mass transfer coefficient is defined by

$$\dot{m}/A = h_m(\rho_{v,w} - \rho_\infty) \quad (1)$$

where  $\dot{m}$  is mass transfer rate,  $A$  is naphthalene sublimation area,  $h_m$  is mass transfer coefficient,  $\rho_{v,w}$  is naphthalene vapor density on the surface, and  $\rho_\infty$  is naphthalene vapor density in the freestream, which is ignored in this study. The empirical equation of Ambrose et al. (1975) is used to determine the naphthalene vapor pressure and then, from the ideal gas law, naphthalene vapor density on the surface is evaluated.

The local mass transfer rate can be determined from

$$\dot{m}/A = \rho_s \Delta t / \Delta \tau \quad (2)$$

where  $\rho_s$  is the density of the solid naphthalene,  $\Delta t$  is the net sublimation depth, and  $\Delta \tau$  is the total exposure time in the wind tunnel. Total naphthalene sublimation depth is calculated from the variation in measured surface elevations before and after the exposure, and the excess sublimation due to natural convection during the sublimation depth measurement period is subtracted from the total sublimation to calculate net sublimation.

Combining Eqs. (1) and (2) gives

$$h_m = \frac{\rho_s \Delta t / \Delta \tau}{\rho_{v,w}} \quad (3)$$

The Sherwood number can be expressed as

$$Sh = h_m H / D_{iff} \quad (4)$$

where  $H$  is the characteristic length, fin spacing in this study. The mass diffusion coefficient of naphthalene in air,  $D_{iff}$  is calculated from Cho's (1989) correlation. The measured mass transfer coefficients or Sherwood numbers are converted to their counterpart of heat transfer using the following analogy relation.

$$Nu/Sh = (hH/k) / (h_m H / D_{iff}) = (Pr/Sc)^n \quad (5)$$

where  $1/3$  is used for exponent  $n$  in the present study.

### 3. Results and Discussion

#### 3.1 Fin-circular tube heat exchanger

Schematic of the fin-tube heat exchanger model with circular tubes in a staggered arrangement is shown in Fig. 1. The heat exchanger models consist of five parallel plate representing the fins and three rows of tubes. Fins are made of 0.8 mm thick stainless-steel and tubes are made of acrylic. Vortex generators, 7 mm  $\times$  7 mm, made of acrylic are mounted vertically on the fins, and fin spacing is the same as the height of vortex generator. The bottom plate of the wind tunnel is cast with naphthalene and heat exchanger model is mounted on it. Results obtained with the inlet air velocity of 7 m/s are presented.

Distribution of the local heat transfer coefficients for fin-circular tube heat exchanger

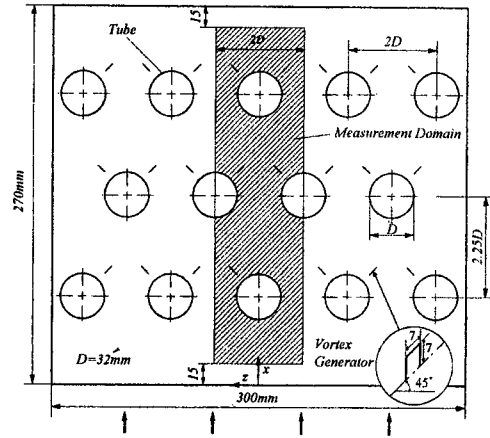

Fig. 1 Schematic of fin-circular tube heat exchanger model

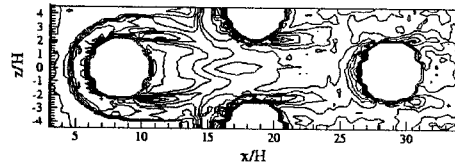
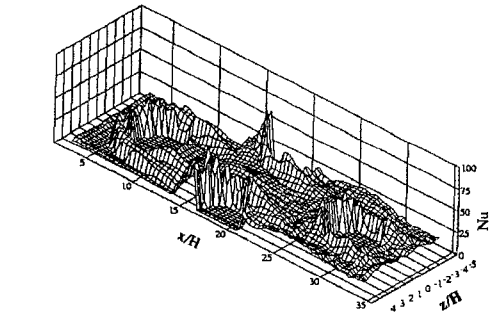

Fig. 2 Distribution of local Nusselt number for fin-circular tube heat exchanger without vortex generators

without vortex generator is shown in Fig. 2. When the boundary layer flow meet the protruding object, tube in the study, flow is slowdown and dynamic pressure converted to static pressure. A pressure gradient across the boundary layer is, therefore, created. This pressure gradient causes the flow to move toward the fin and reverse flow at the region nearest to the fin. This reverse flow of the boundary layer produces the horseshoe vortex, which is then

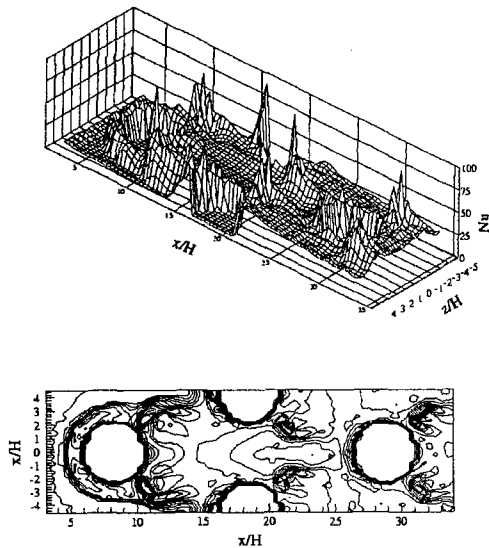

Fig. 3 Distribution of local Nusselt number for fin-circular tube heat exchanger with vortex generators

carried around the tube by the main flow. This horseshoe vortex enhances the convective heat transfer dramatically. Horseshoe-like peak, starting in front of the tube and continuing around the tube, corresponds to the trail of horseshoe vortex. Meanwhile, the heat transfer coefficient behind the circular tube is found to be very low. The reason is that wide wake zone is formed behind the tube, so the fluid in this region is scarcely mixed with the main flow.

Figure 3 shows the distribution of the local heat transfer coefficients for fin-circular tube heat exchanger with vortex generators. Heat transfer enhancement by the horseshoe vortices is similar to that without vortex generator. In addition to this enhancement, another peak trail is found in the downstream of each vortex generator. Longitudinal vortices are generated by flow separation due to the pressure difference between upstream and downstream side of vortex generator. These vortices turn the flow field perpendicular to the main flow direction. They enhance the mixing of the fluids close to and far from the fin and, thereby, the fin heat transfer.

In the Fig. 4, average Nusselt numbers are compared on the fin surface of the fin-circular

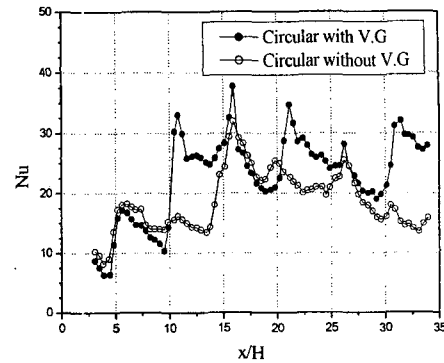

Fig. 4 Comparison of spanwise-averaged heat transfer for fin-circular tube heat exchanger

tube heat exchanger with and without vortex generators. Average Nusselt number is calculated by integrating the local Nusselt numbers along the spanwise-direction. In case of a heat exchanger without vortex generator, three local maximum is found at  $x/H \approx 6$ ,  $x/H \approx 16$  and  $x/H \approx 26$ , which is caused by the horseshoe vortices formed in front of tubes located in the first, second and third row, respectively. Second and third peaks are relatively higher than first peak, because blockage due to the first tube increases the velocity and produces stronger horseshoe vortices in front of second tube. In case of a heat exchanger with vortex generators on the other hand, three additional peaks appear at  $x/H \approx 11$ ,  $x/H \approx 21$  and  $x/H \approx 31$ , which correspond to the location of vortex generators. The magnitude of enhancement by vortex generators are almost same regardless of location, and longitudinal vortices does not influence horseshoe vortices. The overall average heat transfer coefficient on the whole fin surface of the fin-circular tube heat exchanger with vortex generators found to be 35 % higher than that of the fin-circular tube heat exchanger without vortex generator.

### 3.2 Fin-flat tube heat exchanger

Figure 5 shows the schematic of the fin-tube heat exchanger of model with flat tube. The cross sectional area and tube spacing of flat tubes are equal to those of circular tubes. The same vortex generators as is used in the fin-circular tube heat exchanger, are mounted in the upstream side of

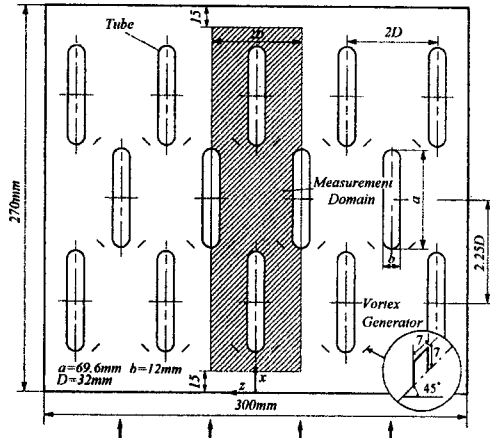

Fig. 5 Schematic of fin-flat tube heat exchanger model

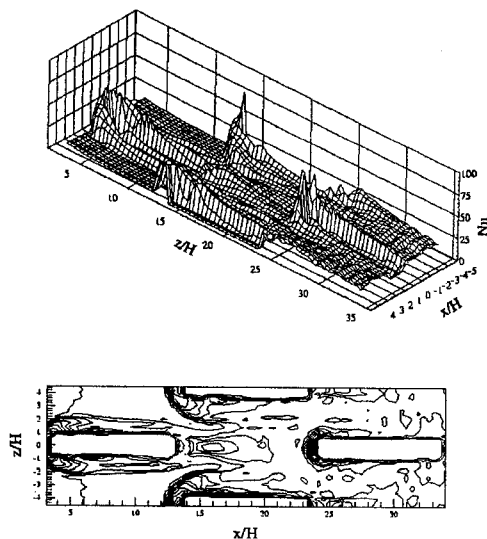

Fig. 6 Distribution of local Nusselt number for fin-flat tube heat exchanger without vortex generators

flat tube. Fin-flat tube heat exchangers are often adopted in air-conditioning and gas-boiler system instead of fin-circular tube heat exchangers, to reduce the pressure loss, consequently pumping cost. But it is well known that heat transfer efficiency of the fin-flat tube heat exchanger is much lower than that of circular type. Yoo (1997) have reported that dual effects, the enhancement of heat transfer and the reduction of pressure loss, could be accomplished by implementing vortex

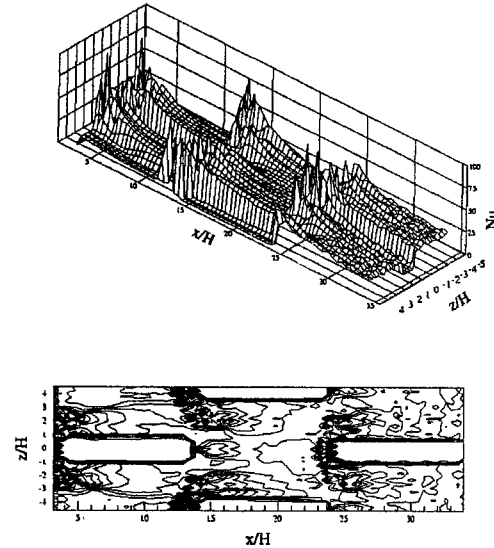

Fig. 7 Distribution of local Nusselt number for fin-flat tube heat exchanger with vortex generators

generators on the fin surface.

Figure 6 shows the distributions of local heat transfer coefficients in the fin-flat tube heat exchanger without vortex generator. Heat transfer enhancement by horseshoe vortices found in front of tubes, as in fin-circular tube heat exchanger, but their magnitude is much less than that of fin-circular tube. Blockage area of flat tube is smaller than circular tube, so intensity of horseshoe vortices formed around flat tubes are weaker. This is the reason why fin-flat tube heat exchanger has lower heat transfer efficiency than fin-circular tube.

Distribution of local heat transfer coefficients in the fin-flat tube heat exchanger with vortex generators is shown in Fig. 7. In addition to heat transfer enhancement by horseshoe vortices, longitudinal vortices created by vortex generators are found to augment heat transfer drastically.

Effect of vortex generators on the heat transfer enhancement in the fin-flat tube heat exchanger is shown in Fig. 8. Because vortex generators are installed nearby upstream side of flat tube, heat transfer enhancement caused by horseshoe vortices and by longitudinal vortices are coupled. The increase in Nusselt number by vortex

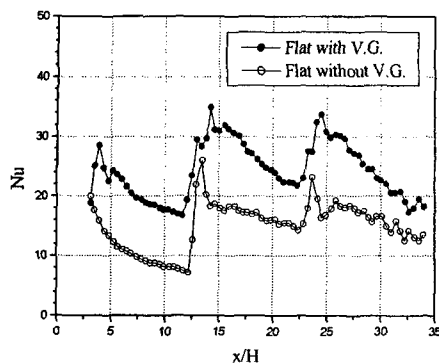

Fig. 8 Comparison of spanwise-averaged heat transfer for fin-flat tube heat exchanger

generators is found to be much higher in the fin-flat tube heat exchanger than fin-circular tube. Overall average heat transfer coefficient of fin-flat tube heat exchanger with vortex generators is increased by 75 % compared to that of the fin-flat tube without vortex generator, and is increased by 45 % compared to that of the fin-circular tube heat exchanger without vortex generator.

### 3.3 Pressure loss

Pressure loss in the fin-tube heat exchangers are measured using a micro-manometer, and the apparent friction factor  $f$  is calculated from the following expression:

$$f = \frac{\Delta P}{\rho V^2 / 2} \cdot \frac{H}{L} \quad (6)$$

where  $H$  is fin spacing, the distance between fins and  $L$  is the distance between pressure measuring points. Figure 9 shows the apparent friction factor against Reynolds number, based on fin spacing, for circular and flat tube heat exchangers with and without vortex generators. Friction factors decrease as the Reynolds number increase, and vortex generators increase pressure drop in both cases. Friction factors for fin-circular tube heat exchanger are much higher than that of flat tube because of relatively larger blockage area. Pressure drop of the fin-flat tube heat exchanger with vortex generators is increased by 80 % compared to that of the fin-flat tube without vortex generator, but is decreased by 50 % compared to that of the fin-circular tube heat

Table 1 Comparison of Nusselt numbers, apparent friction factors and their ratios based on equivalent fan power

Heat Exchanger Type	$\frac{Nu}{Nu_c}$	$\frac{f}{f_c}$	$\left(\frac{Nu}{Nu_c}\right) / \left(\frac{f}{f_c}\right)^{1/3}$
Fin-circular tube	1.00	1.00	1.00
Fin-circular tube with V.G.	1.37	1.17	1.30
Fin-flat tube	0.82	0.29	1.24
Fin-flat tube with V.G.	1.45	0.53	1.79

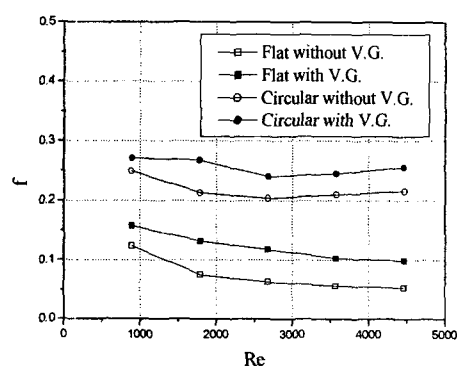

Fig. 9 Comparison of apparent friction factors for four types of heat exchanger

exchanger without vortex generator.

Comparison of Nusselt numbers, friction factors and their ratios based on equivalent fan power at air velocity of 7 m/s for four types of heat exchanger are given in Table 1. Figures in the table indicate the ratio to the values of fin-circular tube heat exchanger without vortex generator. Consequently, fin-flat tube heat exchanger with vortex generators has higher heat transfer efficiency and lower pressure loss than conventional fin-circular tube heat exchanger

## 4. Conclusions

Heat transfer and pressure loss for fin-circular tube and fin-flat tube heat exchangers with and without vortex generators are measured and compared. Summary of major results are as follows.

(1) Horseshoe vortices formed around the tube enhance the heat transfer dramatically, and their effect is relatively weaker in the flat tube.

(2) In case of fin-tube heat exchanger with

vortex generators, longitudinal vortices augment heat transfer in addition to horseshoe vortices.

(3) Overall average heat transfer coefficient of fin-flat tube heat exchanger with vortex generators is increased by 75 % compared to that of the fin-flat tube without vortex generator, and is increased by 45 % compared to that of the fin-circular tube heat exchanger without vortex generator.

(4) Fin-flat tube heat exchanger with vortex generators has higher heat transfer efficiency and lower pressure loss than conventional fin-circular tube heat exchanger.

### Acknowledgment

This study is financially supported by the Ministry of Commerce, Industry & Energy and Dubalgas Engineering through Energy Conservation Program. Authors gratefully appreciate the support.

### References

Ambrose, D., Lawrenson, I. J. and Sparke, C. H. S., 1975, "The Vapor Pressure of

Naphthalene," *J. of Chemical Thermodynamics*, Vol. 7, pp. 1173~1176.

Cho, K., 1989, "Measurement of Diffusion Coefficient of Naphthalene into Air," Ph. D Thesis, State University of New York.

Fiebig, M. and Chen, Y., 1998, "Heat Transfer Enhancement by Wing-type Longitudinal Vortex Generators and Their Application to Finned Oval Tube Heat Exchanger Elements," *Proc. of the NATO Advanced Study Institute on Heat Transfer Enhancement of Heat Exchangers*, pp. 79~105.

Goldstein, R. J., Yoo, S. Y. and Chung, M. K., 1990, "Convective Mass Transfer from a Square Cylinder and Its Base Plate," *Int. J. of Heat and Mass Transfer*, Vol. 33, pp. 9~18.

Yoo, S. Y., 1997, "Development of High Efficiency Fin-Flat Tube Heat Exchanger Using Vortex Generators," *MOTI Report*, No. 95-P-10-2.

Zhu, J. X., Fiebig, M. and Mitra, N. K., 1995, "Numerical Investigation of Turbulent Flows and Heat Transfer in a Rib-Roughened Channel with Longitudinal Vortex Generators," *Int. J. Heat Mass Transfer*, Vol. 38, No. 3, pp. 495~501.