

Catch per Unit Effort and Size Composition of Crayfish, *Astacus leptodactylus* Eschscholtz 1823, in Lake İznik

İsmet Balık*, Ergun Özkök and Remziye Özkök

Fisheries Research Institute, 32500 Eğirdir-Isparta, Turkey

ABSTRACT : This paper was carried out from 15 June to 24 December in 2000 in Lake İznik of Turkey, to determine catch per unit effort (CPUE) and size composition of crayfish, *Astacus leptodactylus* Eschscholtz 1823, captured by fyke-nets of local fishermen. The average CPUE of all size groups was found as 1.65 crayfish/fyke-net/night for fishing season in 2000, but 26.4% of which was below the legal minimum size (crayfish < 90 mm). The average CPUE of legal-sized (crayfish ≥ 90 mm) crayfish was 1.10 crayfish/fyke-net/night. The annual catch of crayfish was estimated as 2990 tonnes. The length and weight compositions of crayfish captured in the fyke-nets have varied between 60 and 130 mm, and 6 and 71 g, respectively. The mean length and weight were found as 95.5 mm and 28.8 g for all size groups and 100.1 mm and 33.0 g for legal-sized individuals. (*Asian-Aust. J. Anim. Sci.* 2002, Vol 15, No. 6 : 884-889)

Key Words : Crayfish, *Astacus leptodactylus*, Fyke-Net, Catch per Unit Effort, Size Composition, Lake İznik

INTRODUCTION

Freshwater crayfish was an especially important fishery resource in Turkey from the early of 1960's to the middle of 1980's. The annual catch of crayfish were 1.275 tonnes in 1975 (Köksal, 1980) and 4.000-6.000 tonnes in 1980's (Duman and Gürel, 2000). Nearly all of this catch was exported to the other European countries, especially France, Sweden, Germany and Italy. Unfortunately, during the period of 1985 to 1987 annual catch of the native crayfish in Turkey decreased rapidly to less than 10 percent of the original size. The reason was an acute outbreak of crayfish plague, *Aphanomyces astaci* Schikora (Furst, 1988). Firstly, the outbreak of the plague occurred in Lake Işıklı (Çivril) in Turkey (Köksal and Korkmaz, 2000). Later, the plague dramatically spread to the other lakes in the country. In recent years, the crayfish populations in the some Turkish lakes, for instance Lake İznik, Uluabat (Apolyont), Eğirdir have considerably increased.

There are excess of 500 species of freshwater crayfish distributed world-wide (Skurdal and Taugbøl, 1994). But, there is only one species of crayfish in the freshwater of Turkey which is *Astacus leptodactylus* Eschscholtz 1823. Two subspecies of this species live in the Turkish lakes which are *Astacus leptodactylus leptodactylus* Eschscholtz 1823 and *Astacus leptodactylus salinus* Nordmann 1842 (Alpbaz, 1993; Demirsoy, 1998). According to Alpbaz (1993), Demirsoy (1998) and Aydın (1998) *A. leptodactylus leptodactylus* was the only native subspecies at the beginning in Lake İznik. But, nowadays the another subspecies may also introduced into this lake. The

devastation of the plague on crayfish population in this lake was less than the other many lakes in Turkey.

Crayfish have been exploited for centuries and have long been economically important and recognised as a delicacy (Brinck, 1975). But, despite their long historical use in Europe, little is known about the management of wild crayfish populations (Skurdal et al., 1993). Current management practice in Europe is to protect native crayfish species through various limitations on catching seasons, minimum sizes, and regulations of catching methods in addition to a variety of local regulations (Westman et al., 1990). In the management of fisheries in the lakes, the population densities of crayfish or fish species must be well known by fishery manager. Estimation of the density of natural crayfish populations requires a methodology designed to assess the population size within a known area. Estimation of population size can be carried out either in terms of relative abundance, using CPUE (catch per unit effort) data or as absolute abundance, using census methods or mark-recapture techniques (Skurdal et al., 1992). It is not always possible to estimate the population density directly. Sometimes researches have to make to with just a relative measure or index of density based on animal signs (Schwarz and Seber, 1999). Therefore, CPUE is the most common method to investigate populations and to arrange fishery activity (Erkoyuncu, 1987). CPUE is a measure of relative abundance (Schwarz and Seber, 1999). If yield could be forecast, the data could be used by authorities to reduce exploitation by reducing legal season or consider other regulations to protect the crayfish (Skurdal et al., 1994a). Crayfish population is very important for fisheries in Lake İznik. But, there was no enough information about this crayfish population. Therefore, the purpose of this study was to determine CPUE and size composition of

* Corresponding Author: İsmet Balık. Tel: +90-246-3112296, Fax: +90-246-3113539, E-mail: i.balik@yahoo.com

Received October 8, 2001; Accepted December 24, 2001

crayfish captured by fyke-nets of local fishermen.

MATERIALS AND METHODS

Lake İznik is located in 40° 26' N and 29° 32' E in the Marmara Region of Turkey, 86.4 m above from the sea level. It has a surface area of 29,800 ha, a maximum depth of 80 m, and a mean depth of 60 m (Aydoğdu et al., 1997). The lake is eutropic (Cirik and Cirik, 1995) and its water level changes smaller (about 0.5 m) than the other many lakes in Turkey (TKB, 1994). According to local authorities of government there were 260 fishing boats for catching crayfish, and each of them had average 1,800 fyke-nets in 2000.

Experiments were conducted at seven different localities of the lake (figure 1). Crayfish were caught by fyke-nets of local fishermen three times each month between 15 June and 24 December in 2000. Fyke-nets are deployed in pair with a single leaders between them (figure 2). There is a leader of webbing attached to the mouths to guide crayfish into the enclosure. They had two funnels made from plastic-coated wires. The nets are set so that leader intercept the movement of crayfish. When crayfish follow the leader in an attempt to get around the netting, they go into the fyke-net. In experiments, 100 fyke-nets were set before noon at 2 m intervals on a nylon line in each experimental area. After three days, fyke-nets were checked and crayfish harvested, and they were returned to the same areas. The total body length (TL) of crayfish was measured (to the nearest mm) with a ruler from the tip of the acumen to the posterior edge of the telson excluding the setae. Crayfish were also weighed to the nearest 0.1 g.

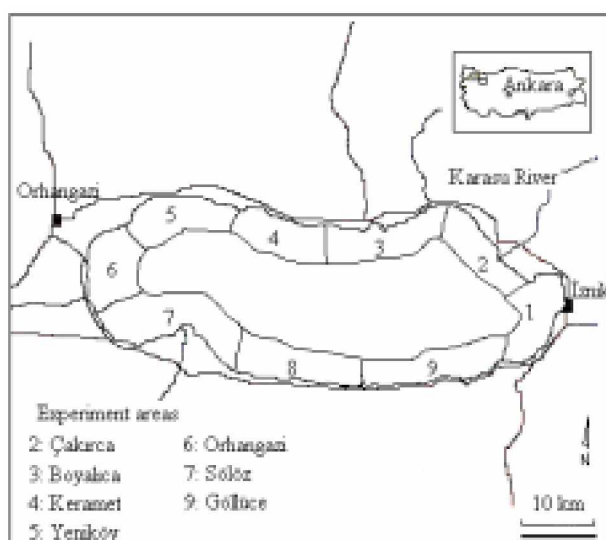

Figure 1. The map of Lake İznik and experiment areas.

CPUE is expressed as number of crayfish per fyke-net

per night (Skurdal et al., 1994a). The average CPUE and seasonal changes in CPUE were determined between June and December in 2000. Population density of crayfish was estimated using CPUE and total annual fyke-net effort. The total catch of legal-sized crayfish removed was calculated using the equation $C_t = f \cdot (c_i/f_i)$ (Qvenild and Skurdal, 1984). Where is C_t : total catch, f : total annual catch effort, c_i/f_i : catch per unit effort. In all of the Turkish lakes, minimum legal size is ≥ 90 mm total length and legal catching season is from 15 June to 24 December for fishing crayfish (TKB, 2000). In addition, the length and weight compositions were determined from the lengths and weights of crayfish captured in the fyke-nets.

Differences in CPUEs between the seven different localities of the lake and months were determined through ANOVA. The Students-Newman-Keuls test was applied for comparison of pairs of CPUEs of legal-sized crayfish of monthly and different localities (Çömlekçi, 1988).

RESULTS

The CPUEs of crayfish captured in the seven different localities of the lake have varied between 1.13 and 2.18 crayfish/fyke-net/night for all size groups and between 0.76 and 1.46 crayfish/fyke-net/night for legal-sized individuals (crayfish ≥ 90 mm). The highest CPUE was found in the Göllüce locality of the lake. This locality was followed by Sölöz, Orhangazi, Yeniköy, Keramet, Çakırca and Boyalıca localities, respectively (table 1). The CPUE of crayfish for the seven different localities of the lake were somewhat different, but differences between the localities were not statistically significant ($p > 0.05$).

As indicated in figure 3, the CPUEs of legal-sized crayfish in June and July were highly lower than the other months. They increased gradually from June to December. But, the increase was very slightly especially from September to December. Differences in CPUEs between June and July was not significant ($p > 0.05$), but the differences between these months and the other months

Table 1. The average CPUEs of all size groups and legal-sized individuals for the seven different experiment areas

Area	All size groups	Crayfish ≥ 90 mm
	N \pm SE	N \pm SE
Yeniköy	1.72 \pm 0.2714	1.15 \pm 0.1819
Orhangazi	1.71 \pm 0.3116	1.14 \pm 0.2088
Göllüce	2.18 \pm 0.3928	1.46 \pm 0.2631
Çakırca	1.31 \pm 0.3240	0.87 \pm 0.2170
Keramet	1.56 \pm 0.2489	1.04 \pm 0.1668
Boyalıca	1.13 \pm 0.2161	0.76 \pm 0.1447
Sölöz	1.94 \pm 0.3914	1.29 \pm 0.2620
Average	1.65 \pm 0.1349	1.10 \pm 0.0904

were significant ($p < 0.05$). Differences of the CPUEs from

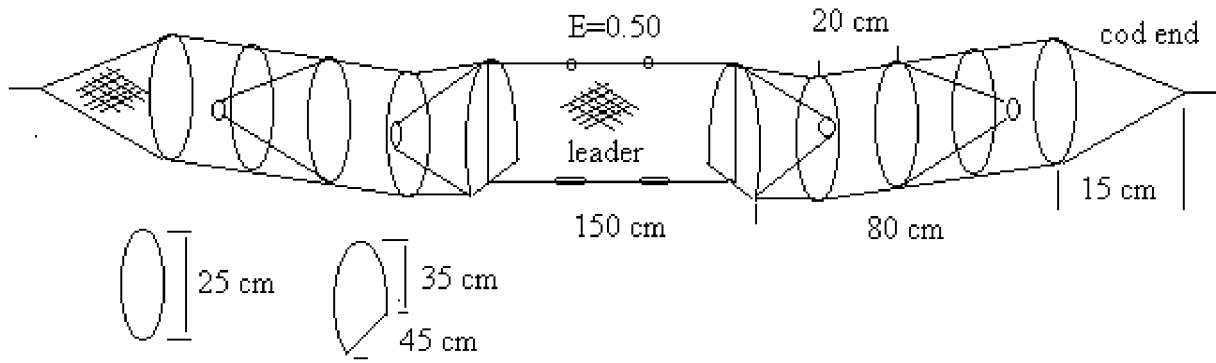

Figure 2. The shape of the experimental fyke-nets.

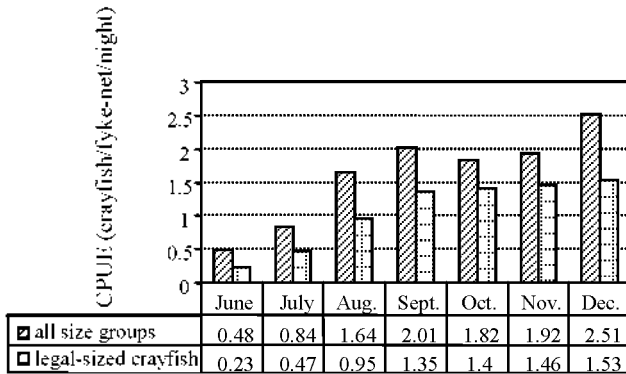

Figure 3. Seasonal changes of CPUE of all size groups and legal-sized crayfish.

August to December were not statistically significant ($p > 0.05$). During the study, generally the ratios of non-legal- and legal-sized crayfish in the catches were similar.

During the fishing season, except for only three days in each month fyke-nets were continuously set on the bottom of the lake. They were lifted to clean from the materials (algae, macrophyte, mud, etc) for three days per month. Therefore, a total of 176 nights crayfish were captured by fyke-nets. The total annual catch effort (f) was estimated to be 82,368 million (260 boats·1,800 fyke-nets·176 nights) fyke-nets/season. The average CPUE of legal-sized crayfish (c_i/f_i) was found as 1.1 individuals/fyke-net/night from 15 June to 24 December. The yield (C_i) was calculated as follow.

$$C_i = 82368000 \cdot 1.1 \quad C_i = 90604800 \text{ crayfish or } 90604800 \cdot 33 \text{ g} = 2990\ 000\ 000 \text{ g} = 2990 \text{ tonnes}$$

The mean length and weight were found as 95.5 mm and 28.8 g for all size groups and 100.1 mm and 33.0 g for legal-sized individuals. The length composition has varied between 60 and 130 mm. Most crayfish were caught between 90 and 100 mm (figure 4), and the weight of the largest crayfish was 71 g. The weight groups' rates between 15 and 39 g were higher than the other weight groups. It

was shown as in figure 5, the rate of crayfish > 55 g was very low.

DISCUSSION

CPUE is directly proportional to the existing population size. In exploited populations it may be possible to estimate

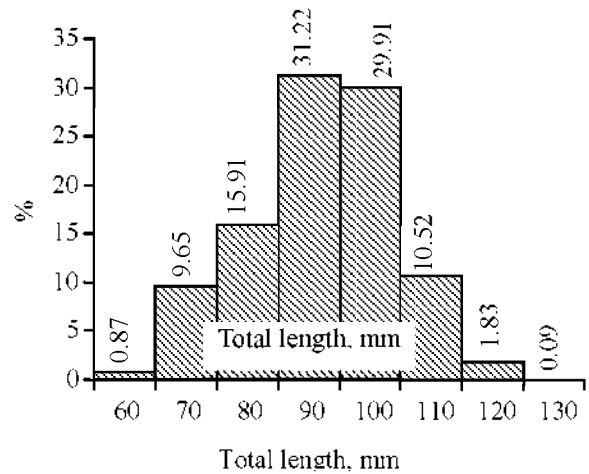

Figure 4. The length composition of crayfish population from June to December

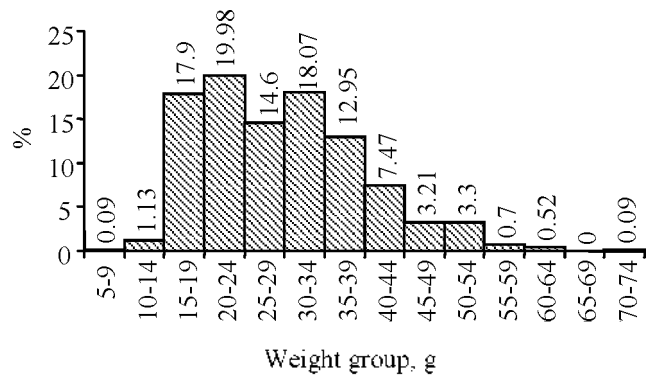

Figure 5. The weight composition of crayfish population from June to December

population size by the decline in CPUE with time (Krebs, 1989). However, crayfish catchability is influenced by a number of factors such as size, sex, molting, reproduction, health condition, temperature (Capelli and Magnuson, 1975; Abrahamsson, 1983; Skurdal et al., 1988), weather patterns, water quality, moon phase, trap design, trap density, number of trapping days, trapping strategy, population density and size structure (Romaine, 1995). During the years prior to 1981 cylindrical traps were used for catching the crayfish in Lake İznik. Later fyke-nets were used in increasing numbers (Furst, 1988). In recent years, only fyke-nets have been used by fishermen for catching crayfish in this lake. In this study, the average CPUE was estimated as 1.1 legal-sized crayfish/fyke-net/night in the fishing season in 2000. CPUE of *A. leptodactylus salinus* was reported as 2.22 crayfish/fyke-net/night in Dikilitaş Reservoir by Köksal and Korkmaz (2000) and 0.13 crayfish/trap/night in the Hoyran part of Lake Eğirdir of Turkey by Bolat (2001). The CPUE in Lake İznik was significantly higher than the Hoyran part of Lake Eğirdir, but it was nearly half of Dikilitaş Reservoir. In Lake Steinsfjorden of Norway, CPUE of *Astacus astacus* L. varied between 5.3 and 22.9 crayfish/trap from 1980 to 1988 (Skurdal et al., 1994a). Goldman and Rundquist (1977) informed that CPUE of *Pacifastacus lenisculus* (Dana) was between 1.2 and 3.9 crayfish/trap for Lake Tahoe in 1974 and 1.64 to 3.34 crayfish/trap for Lake Donner in 1975. The CPUE data of Lake İznik was low compared to these values. However, the studies except for Dikilitaş Reservoir were not suitable for comparative analysis because all of the other studies were conducted by traps. Also, in all the lakes species or subspecies of crayfish were different to those from Lake İznik. CPUE may be influenced by kind of apparatus and species or subspecies of crayfish. In addition, it is influenced by density of fyke-nets or traps. Romaine (1995) claimed that crayfish yield increased 49% with an increase in trap density from 30 to 60 traps/ha, but yield increased only 8% with an increase in density from 60 to 90 traps/ha. Total fyke-net effort in Lake İznik was a total of 468,000 fyke-nets/night in 2000. This lake has a surface of 29,800 ha, but crayfish were caught in only about 30% of the total surface. Because, its depth reaches up to 80 m. In this lake, generally crayfish are captured between 5 and 20 m, and according to the local fishermen crayfish are not captured in the depth more than 30 m. It is well known from the other studies that crayfish do not prefer deeper than about 40 m. For instance, Abrahamsson and Goldman (1970) informed that the density of crayfish population shows a maximum at the depth of 10 to 20 m. The lower density of crayfish is at 0 to 10 m depth in Lake Tahoe. In Lake Steinsfjorden, generally seasonal distribution of *A. astacus* varied between 1 and 17 m dependent on temperature (Skurdal et al., 1988).

Reproduction requires temperatures above 15°C (Abrahamsson, 1972) and molting is restrained in cold waters. This probably is an important factor regulating depth distribution (Skurdal et al., 1988).

The annual catch was estimated as 2,990 tonnes in 2000. This catch amount was very important for fisheries in Lake İznik. Because, even the annual catch of crayfish in Europe is about only 7,000-8,000 tonnes (Skurdal and Taugbøl, 1994).

Long-term seasonal changes in crayfish catch are predictable because it is largely regulated by seasonal changes in water temperature (Araujo and Romaine, 1989), but daily changes can not be forecast with accuracy. Seasonal and daily variations in catches are controlled by environmental factors, pond management and market considerations (Romaine, 1995). In lake İznik, it was determined that during the fishing season the CPUE varied. In June and July it was low when compared to the other months. It increased continuously from June to December. The increase was very high from June to August, but especially it was almost stable between September and December. Seasonal changes may be influenced by many factors such as reproduction, molting, temperature. Crayfish in the Turkish lakes mate between November and December, and embryonic development of eggs under abdomens of female crayfish last about 4 to 6 months and generally young crayfish are seen between May and July. In addition, adult male crayfish moult twice per year in June and September, females once in July or August (Çelikkale, 1988). During the study, water temperature in Lake İznik increased from June to August and thereafter decreased continuously until December. Therefore, CPUE in June and July were probably negatively influenced by temperature, reproduction and molting in Lake İznik. Temperature affects the activity, and therefore the catchability of crayfish (Capelli and Magnuson, 1975; Skurdal et al., 1988). Catchability is also influenced by molting and reproductive cycle (Skurdal et al., 1988). Because, crayfish in this period are probably less active than the other seasons. According to Erdenli (1982), in the many Turkish lakes catch of crayfish decrease in summer especially due to molting. Bolat and Aksoylar (1997) reported that CPUEs in October, November and December were higher than the other months in Lake Eğirdir because of mating in these months.

The mean length (100.1 mm) and weight (33 g) of legal-sized crayfish captured in the fyke-nets of local fishermen were low compared to the other some crayfish populations. The mean length and weight were found as 108.18 mm and 40.67 g in Dam Lake Ayrancı by Erdem and Erdem (1994), 103.48 mm and 33.98 g in Lake Hotamuş and 109.7 mm and 38.72 g in Mamasin Dam Lake by Erdenli (1987), 104.4 mm and 34.5 g in Lake Mogan by Karabatak and Tüzün (1989), 53.3 mm and 45.8 g in Hoyran part of Lake Eğirdir

by Bolat (2001). According to Nefedov and Mazanov (1973), males and females of *A. leptodactylus* were able to reach to the 175 and 94 g weight, respectively. But, the maximum size of crayfish population in Lake İznik was found to be 130 mm and 71 g. These values were reported as 104.43 mm and 34.55 g in Lake Mogan (Karabatak and Tüzün, 1989), 145 mm and 92.5 g in Dikilitaş Reservoir (Köksal and Korkmaz, 2000), and 172 mm and 171.4 g in Hoyran part of Lake Eğirdir (Bolat and Aksoylar, 1997).

A minimum legal size for fishing crayfish was ≥ 90 mm total length in the Turkish lakes (TKB, 2000). In this study, the rate of legal-sized crayfish captured in the fyke-nets by local fishermen was determined to be 73.7%, but 26.3% of individuals was non-legal-sized. According to the legislation, non-legal-sized crayfish are to be released into the lake immediately (TKB, 2000). But, handling stress when caught and released may increase mortality of non-legal-sized crayfish (Skurdal et al., 1994b). Therefore, rate of non-legal-sized individuals in catches should be decreased.

In conclusion, yearly changes in CPUE should be determined continuously for catching crayfish in this lake in the future. Registration of CPUE data from local fishermen can help managers to decide if a change in regulations to protect the crayfish population is needed. The CPUE data are also reliable monitors of relative population changes in abundance over the years (Skurdal et al., 1994a). In addition, the mesh size of fyke-nets using by local fishermen in the lake is 17 mm (knot to knot). Therefore, the mesh size of fyke-nets should be increased from 17 mm to at least 20 mm to decrease the rate of non-legal-sized crayfish.

REFERENCES

- Abrahamsson, S. A. A. 1966. Dynamics of an isolated population of the crayfish, *Astacus astacus* Linne. OIKOS 17:96-107.
- Abrahamsson, S. A. A. and C. R. Goldman. 1970. Distribution, density and production of the crayfish *Pacifastacus leniusculus* Dana in Lake Tahoe, California-Nevada. OIKOS 21:83-91.
- Abrahamsson, S. 1972. Fecundity and growth of some populations of *Astacus astacus* Linne in Sweden. Rep. Inst. Freshwater Res. Drottningholm 52:23-27.
- Abrahamsson, S. 1983. Trapability, locomotion, and diet pattern of activity of the crayfish *Astacus astacus* and *Pacifastacus leniusculus* Dana. Freshwater Crayfish 5:239-253.
- Alpbaz, A. G. 1993. Kabuklu ve Eklem Bacaklılar Yetiştiriciliği. Ege Üniversitesi Su Ürünleri Fakültesi Yayınları No. 26, İzmir.
- Araujo, M. and R. P. Romaire. 1989. Effects of water quality, weather, and lunar phase on crawfish catch. J. World Aquacult. Soc. 20:199-207.
- Aydın, H. 1998. Growth and maturity of freshwater crayfish (*Astacus leptodactylus leptodactylus* Esch. 1823) juvenils in concrete fish ponds. First International Symposium on Fisheries and Proceedings, Trabzon/Turkey, pp. 487-491.
- Aydoğdu, A., H. S. Yıldırımhan and F. N. Altunel. 1997. İznik Gölü'nden yakalanan akbalık (*Rutilus frisii* L.)'nin helminth faunası üzerine bir araştırma. IX. Ulusal Su Ürünleri Sempozyumu, Eğirdir/Isparta, Cilt II:431-443.
- Bolat, Y. 2001. Eğirdir Gölü Hoyran Bölgesi Tatlısu İstakozlarının (*Astacus leptodactylus salinus* Nordmann 1842) Populasyon Büyüklüğünün Tahmini. Doktora Tezi, Süleyman Demirel Üniversitesi Fen Bilimleri Enstitüsü, Isparta.
- Bolat, Y. and Y. Aksoylar. 1997. Eğirdir Gölü kerevitlerine (*Astacus leptodactylus salinus*, Nordman 1842) genel bir bakış. IX. Ulusal Su Ürünleri Sempozyumu, Eğirdir/Isparta, Cilt I: 257-269.
- Brinck, P. 1975. Crayfish in Sweden. Freshwater Crayfish 2:609-620.
- Capelli, G. M. and J. J. Magnuson. 1975. Reproduction, molting, and distribution of *Orconectes propinquus* (Giard) in relation to temperature in a northern mesotrophic lake. Freshwater Crayfish 2:415-427.
- Cirik, S. and Ş. Cirik. 1995. Limnoloji (Ders Kitabı). II. Baskı. Ege Üniversitesi Su Ürünleri Fakültesi Yayınları No: 21, İzmir.
- Çelikkale, M. S. 1988. İçsu Balıkları ve Yetiştiriciliği. Cilt-II, K.T.Ü Sürmene Deniz Bilimleri ve Teknolojisi Yüksekokulu, Genel Yay. No:124, Fakülte Yay. No:2, Trabzon.
- Çömlekçi, N. 1988. Deney Tasarımı ve Çözümlemesi. Anadolu Üniversitesi, Eğitim, Sağlık ve Bilimsel Araştırma Çalışmaları Vakfı yayınları No:58, Eskişehir.
- Demirsoy, A. 1998. Yaşamın Temel Kuralları, Omurgasızlar=İnvertebrata, II. Baskı, Cilt-II/Kısım-I, Ankara.
- Duman, E. and A. Gürel. 2000. Keban Baraj Gölü Ağın Bölgesi'nde yaşayan kerevitin (*Astacus leptodactylus salinus* Nordmann 1842) üreme özelliklerinin belirlenmesi. Su Ürünleri Sempozyumu, Erzurum, pp. 141-150.
- Erdem, U. and Ü. Erdem. 1994. Ayrancı Baraj Gölündeki (Karaman) tatlısu istakozu (*Astacus leptodactylus* Esch. 1823)'nin bazı biyo-ekolojik ve morfolojik özelliklerinin incelenmesi. XII. Ulusal Biyoloji Kongresi, Edirne, pp. 358-361.
- Erdemli, A. Ü. 1982. Beyşehir, Eğirdir, Akşehir, Eber Gölleri ile Apa Baraj Gölünde tatlısu istakozu (*Astacus leptodactylus* Esch., 1823) populasyonlarının bazı biyolojik ve morfolojik özellikleri üzerinde karşılaştırmalı bir araştırma. Türkiye Bilimsel ve Teknik Araştırma Kurumu, Veteriner Hayvancılık Araştırma Grubu, Proje No: VHAG-490.
- Erdemli, A. Ü. 1987. Hotamış Gölü ile Mamasın Barajı tatlısu istakozu populasyonlarının karşılaştırmalı incelenmesi. DOĞA TU Zooloji Derg. 11:16-23.
- Erkoyuncu, İ. 1987. Av miktarı ve av çabası verilerinden populasyon büyüklüğünü tahmin yöntemleri. Ege Üniversitesi Su Ürünleri Yüksek Okulu Su Ürünleri Dergisi 4:54-59.
- Furst, M. 1988. Future perspectives for Turkish crayfish fishery. İstanbul Üniversitesi Su Ürünleri Yüksek Okulu Su Ürünleri Dergisi 2:139-147.
- Goldman, C. R. and J. C. Rundquist. 1977. A comparative ecological study of the california crayfish, *Pacifastacus leniusculus* (Dana), from two subalpine lakes (Lake Tahoe and Lake Donner). Freshwater Crayfish 3:51-80.
- Karabatak, M. and İ. Tüzün. 1989. Mogan Gölü'ndeki kerevit (*Astacus leptodactylus* Esch., 1823) populasyonunun bazı özellikleri. Akdeniz Üniversitesi Su Ürünleri Mühendisliği Dergisi 2:1-34.

- Köksal, G. 1980. Biometric analysis on the freshwater crayfish (*Astacus leptodactylus* Esch. 1823) which is produced in Turkey-relationship between the major body components and meat yield. Ankara Üniversitesi Veteriner Fakültesi Dergisi 26: 93-114.
- Köksal, G. and Ş. Korkmaz. 2000. Ankara-Dikilitaş Göleti Tatlısu İstakozlarının (*Astacus leptodactylus* Esch., 1823) Populasyon Büyüklüğünün Tahmini. Ankara Üniversitesi Ziraat Fakültesi Su Ürünleri Bölümü, Ankara.
- Krebs, C. J. 1989. Ecological methodology. Harper and Row. Publ., New York, pp. 162-166.
- Nefedov, V. N. and N. N. Mazanov. 1973. Determination of the weight of *Astacus leptodactylus* Eschholz based on body length. Hidrobiol. Zh. 9:102-105.
- Qvenild, T. and J. Skurdal. 1984. Krebsefisket I Steinsfjorden of Tyriðfjorden. Metodeutvikling. Tyriðfjordutvalget Fagrapport 27 (In Norwegian).
- Rhodes, C. P. and D. M. Holdich. 1984. Length-weight relationship, muscle production and proximate composition of the freshwater crayfish *Austropotamobius pallipes* (Lereboullet). Aquaculture 37:107-123.
- Romaire, R. P. 1995. Harvesting methods and strategies used commercial procambarid crawfish aquaculture. Journal of Shellfish Research 14:545-551.
- Schwarz, C. J. and G. A. F. Seber. 1999. Estimating Animal Abundance: Review III, Statistical Science 14:427-456.
- Skurdal, J. and T. Taugbøl. 1994. Biology, Culture and Management of the Noble Crayfish *Astacus astacus* L. Ph. D. Thesis, University of Oslo, Norway.
- Skurdal, J., E. Fjeld, D. O. Hessen, T. Taugbøl and E. Dehli. 1988. experiments with noble crayfish *Astacus astacus* L., in a Norwegian lake. Aquaculture and Fisheries Management 23: 227-233.
- Skurdal, J., T. Qvenild and T. Taugbøl. 1994b. Size and sex composition of noble crayfish *Astacus astacus* L. in trap catches in Lake Steinsfjorden, S.E. Norway.: Biology, Culture and Management of the Noble Crayfish *Astacus astacus* L., pp. 207-220.
- Skurdal, J., T. Qvenild, T. Taugbøl and E. Garnas. 1993. Long term study of exploitation, yield and stock structure of noble crayfish *Astacus astacus* in Lake Steinsfjorden. S.E. Norway, Freshwater Crayfish 9:118-133.
- Skurdal, J., T. Qvenild, T. Taugbøl and E. Garnas. 1994a. Can catch per unit effort data (CPUE) forecast yield in an exploited noble crayfish *Astacus astacus* L. Population?: Biology, Culture and Management of the Noble Crayfish *Astacus astacus* L., pp. 191-203.
- TKB. 1994. Türkiye'deki İçsular ve Balık Çiftlikleri İncelemesi, Bazı Göllerin Ekolojisi. Cilt 7, Tarım ve Köyişleri Bakanlığı Tarımsal Üretim ve Geliştirme Genel Müdürlüğü, Ankara.
- TKB. 2000. Denizlerde ve İçsulara Ticari Amaçlı Su Ürünleri Avcılığını Düzenleyen 2000-2002 Av Dönemine Ait 34/1 Numaralı Sirküler, Tarım ve Köyişleri Bakanlığı Koruma ve Kontrol Genel Müdürlüğü, Ankara.
- Westman, K., M. Pursiainen and P. Westman. 1990. Status of Crayfish Stocks, Fisheries, Diseases and Culture in Europe. Report of the FAO European Inland Fisheries Advisory Commission (EIFAC) Working Party on Crayfish, Finnish Game and Fish., Research Institute Report No. 3, Helsinki, Finland.

Dept distribution, habitat segregation and feeding of the crayfis *Astacus astacus* in Lake Steinsfjorden, E.E. Norway. Nordic J. Fresw. Res. 64:113-119.

Skurdal, J., T. Qvenild and T. Taugbøl. 1992. Mark-recapture