

## ATM 통신망의 성능관리를 위한 시스템구조\*

권혁인\*\*

### System Architecture for Performance Management in ATM Network

Hyeog In Kwon

#### Abstract

ATM is the transport method for the broadband integrated services digital networks(B-ISDN). It may replace existing LAN, MAN and WAN technologies such as CSMA/CD, FDDI, Frame relay, X.25, etc. But it is more complicate than existing network technologies. One of the main difficulties in ATM network is performance management. Specifically, the problems are evaluating the performance and tuning the values of the performance parameters.

The goal of this paper is to introduce a system architecture designed for ATM network performance management. The major ingredients of the system are generic performance parameters to be measured from ATM network, performance evaluation models and decision criteria concerning the network performance. In this paper, general requirements for performance management application in ATM network are discussed.

**key word** : System Architecture, Performance Management, ATM Network

---

\* 본 연구는 한국과학재단의 지원에 의한 핵심전문연구과제 사업(981-0918-093-1)으로 수행되었음  
\*\* 중앙대학교 경영학과 교수

## 1. Introduction

ATM(Asynchronous Transfer Mode) is a connection-oriented fast packet-switching protocol that has been standardized for the B-ISDN(Broadband Integrated Services Digital Network) [1, 2, 3].

ATM's important characteristic is that it can handle all types of traffic on one physical medium. That is, it can support voice, video and data communication on one connection. But these various kinds of services supported by ATM require different bandwidth guarantees, different priorities, etc.

Also, ATM is so sophisticated and complex that it is unfunctional with most existing network management solutions.

ATM Forum was started in 1991 to promote ATM standards and to help bring it to the market quickly.

The Forum produces communication infrastructure specifications and also management specifications. But the ATM switching is not a matter of concern of the standard organization. Each vendor's switch has its own merits and drawbacks, in terms of throughput, delay, scalability, buffer sharing, and traffic control. Unfortunately, most existing solutions to the problems of ATM network management don't handle multi-vendor ATM devices.

In many situations, ATM virtual

circuits could be configured over multi-vendor devices. It means that network management tools must have the capabilities to support performance management in heterogeneous(or multi-vendor) network environment. An intelligent and proactive approach to event filtering and correlation, and to performance tuning processes across a heterogeneous network is required. Functions more than basic monitoring of the network should be provided. As ATM introduces much complexity in networking technology with the support of multiple traffic types, traffic management should be included in performance management.

Network management functions are classified into 5 areas by ISO: fault management, configuration management, accounting management, performance management and security management [8]. The performance management in heterogeneous ATM networks is the main concern of this paper.

The goal of performance management is to maintain the customer's service level and to ensure that the communication network is operating effectively. The decision making process to support this goal can be divided into operational decisions based on short term conditions, tactical decisions based on medium-term conditions, strategic decisions based on long-term conditions [10]. To support

efficiently these processes in heterogeneous context, we need a centralized performance management system that can collect, evaluate and control the performance parameters through unified view.

The performance management activity consists in monitoring the status of the networks, in extracting and evaluating performance parameters, in analyzing the situation and in tuning the system. In other terms, it consists of gathering statistical data, of maintaining and examining logs of system state histories, of determining system performance under provided informations, and of altering system mode of operation [8, 9].

In section 2, we will introduce recent

advances in ATM network management. ATM Forum's network management model and some network management solutions are also introduced. In section 3, implementation issues related to performance management are mentioned. And then, a system architecture designed for ATM network performance management is explained in detail in section 4.

## 2. Recent advances

### (Performance management issues)

An ATM network provides end-to-end network performance perceived by users for a connection, characterized mainly in terms of the cell loss ratio and cell

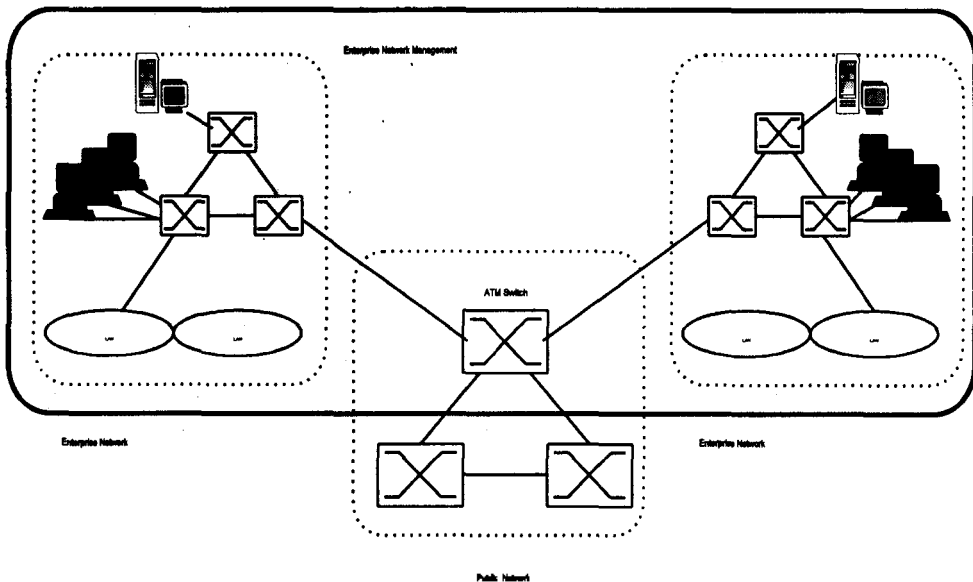

<Figure 1> Enterprise NMS's domains

delays. A range of voice, video, and data services are supported above the ATM layer through a number of service-specific ATM adaptation layers.

There are two types of connections that can be established in an ATM network. PVC(Permanent Virtual Circuits) is established by the network management systems permanently and SVC(Switched Virtual Circuit) is established on demand. Information is communicated along the established path, which has been negotiated within the network.

The negotiation concerns type, speed and other attributes, which jointly determine the end-to-end quality of service provided by the path. Therefore, network management capability should be

reached to both of the enterprise and the public network level. Figure 1 shows the management domain of an enterprise NMS.

In the figure, the public network provides ATM network interfaces to the enterprise. The public network is managed using an OSI infrastructure. The interface supports SNMP communications and provides a constrained vision of the public network.

The logical network view provided to the enterprise has a single ATM switch in it. That is, all their connection points are interconnected by a single ATM switch. The enterprise's NMS interacts with both the enterprise network elements, and the public network elements via CNM interface (see Figure 2).

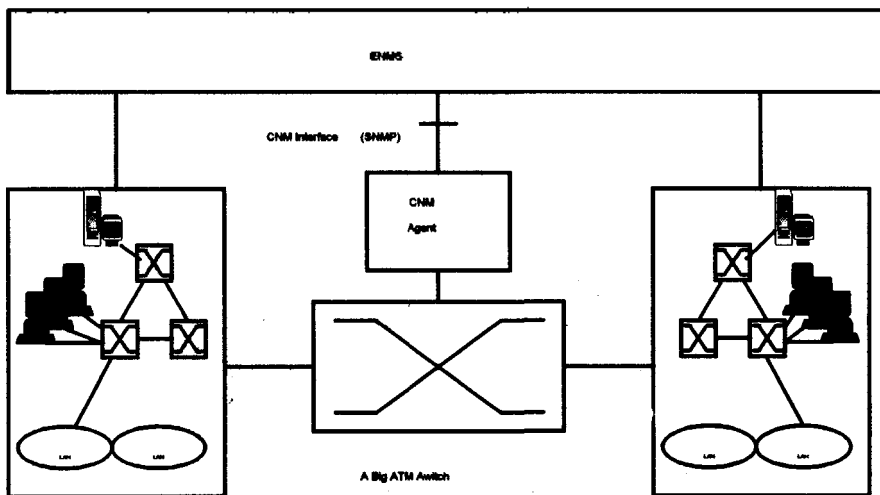

<Figure 2> A logical view of a public network

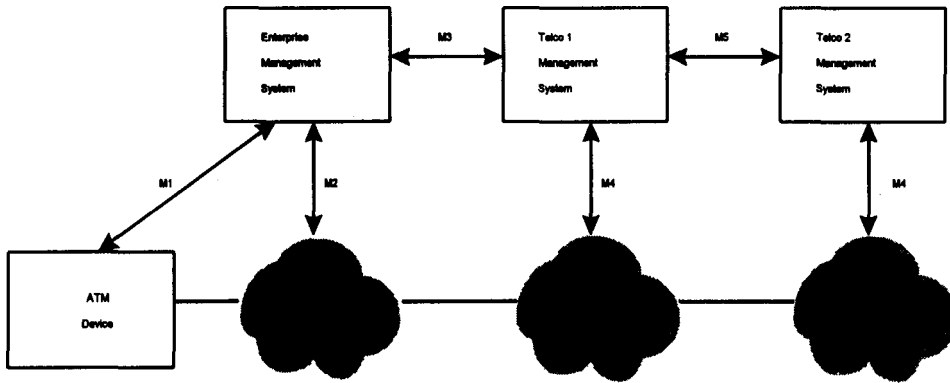

<Figure 3> ATM Forum's Network Management Model

The ATM network management model defined by the ATM Forum recently, defines five work areas for network management(see <Figure 3>).

- Management of ATM end devices(M1)
- Management of private ATM networks or switches(M2)
- Management links between public and private networks(M3)
- Management of public networks(M4)
- Management links between 2 public networks(M5)

The M3 interface refers to the customer control of their portion of the public ATM network and allows a consistent view to be supported by multiple vendors. It would provide the direct interface to and control of the ATM configuration information.

In addition, it provides performance management capability to enterprise NMS allowing monitoring of the service. The single switch view provided by the M3

interface hides the complexity of the public network.

Enterprise who buy services from more than one Telco would find the complexity of integration. Even if the service interface with the service provider were well normalized, the service behaviour(traffic control, routing, etc.) provided by each Telco to customer will be different. That is, Enterprise NMS's activity based on the information captured through the M3 interface could be different in each Telco network.

In the market, there are several ATM network management solutions. Some of them are introduced in below.

*Cisco's AtmDirector* automatically discovers and illustrates the topology of an ATM network, displays real-time link information, and traces the entire path of an ATM link. It can obtain status information on any port or module. But, it works for configuring, monitoring, and

troubleshooting a network of Cisco's ATM switches and other their products.

*IBM's NetView* for AIX(IBM's UNLX OS) manages a series of IBM's ATM products. It is a private network manager, which gives a distributed network manager view of the network to network administrator. NetView for AIX communicate with NetView/390 which is for managing large networks with heterogeneous transport and management protocols.

*Stanford Telecom's NetCoach* is a network management system for multi-vendor ATM networks. It is composed of fault manager, distribution manager, performance manager and simulation manager. Even though not including all functionalities of NMS in NetCoach, they have tried to solve heterogeneity problems coming from multi-vendor environment.

Collecting data for performance management, analyzing the performance, and tuning the network are not simple matters. If something goes wrong in the high-speed network, many cells could be discarded. Network management solution for ATM environment must resolve many difficult problems to ensure the quality of service of the network. ATM Form are preparing standard interfaces for the solution. But, internal functions of the enterprise NMS, and accurate tuning of private ATM switching devices(i.e.,

adjusting traffic parameters and resizing buffer size for a specific class of service) will be left as enterprise NMS's responsibility.

### 3. ATM Network Performance Management Issues

For managing the performance of a heterogeneous network consisted of multi-vendor switches, we have to solve heterogeneity problems, performance heterogeneity, manufacturer heterogeneity, responsibilities heterogeneity, architecture heterogeneity and data heterogeneity[11]. The performance heterogeneity problem could be tackled at the performance management application and the remaining problems at the platform.

As important ingredients of a performance management application, there are

- generic performance parameters to be measured from real networks,
- performance evaluation models to be used when the network performance must be evaluated,
- decision criteria concerning the network performance.

Monitoring the performance and tuning the values of the parameters are not easy problems. We need an intelligent management platform providing distributed

control capable of optimizing the performance of the system by efficiently tuning the parameters. But the meaning of parameters to tune is very different in each ATM switch. Therefore, for managing multi-vendor ATM switches, we have to define the different parameters in consistent way. In this section, we discuss differences of internal ATM switching and traffic control problems which influence performance monitoring and tuning.

**ATM Switching** is not a part of the ATM standard. Each design has its merits and drawbacks. The level of switching complexity and management capabilities is different in each switch. Naturally, a large number of ATM switch design alternatives exist. There are many

alternatives in the hardware and the software components. Cell buffering scheme is one example of differences between switch fabrics. In <Figure 4> below, two buffering schemes, single buffer per output port and separate buffer per connections, are shown.

A single buffer per connection has several important advantages over a single buffer for a output port. First, different priorities can be assigned to different output buffers.

It allows to give different QoS for each connection.

Second, The Early Packet Discard(EPD) and Partial Packet Discard(PPD) mechanisms can be applied to each connection. These mechanisms cannot be used to a single buffer for a

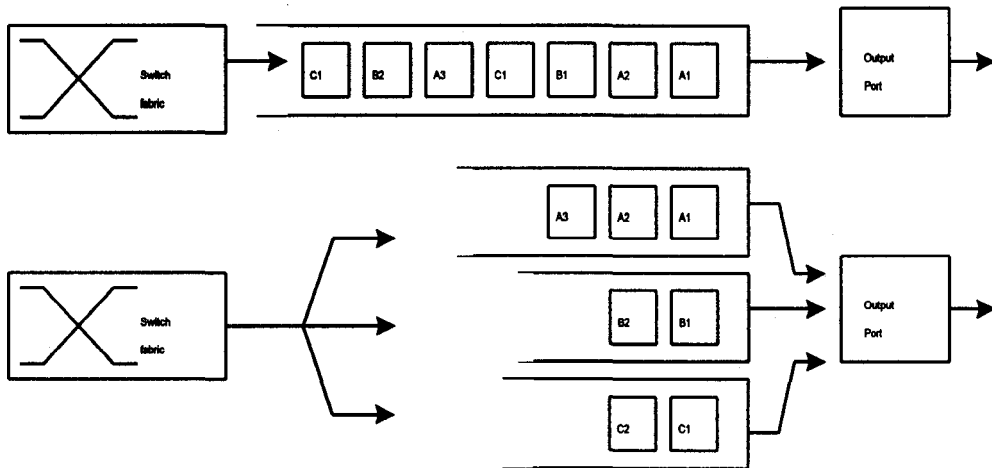

<Figure 4> A single buffer per output port vs. a separate buffer per connections

output port scheme.

The buffering scheme is only one example of differences of switch design which can impact on performance monitoring and tuning.

**Traffic control** capability of a switch is another major area of study for performance management. Traffic control refers to the actions taken by the network to avoid congestion. Congestion can be caused by unpredictable statistical fluctuation of traffic flows and fault conditions within the network. To help avoid congestion, the following traffic control functions can be included partly in ATM switch and partly in source /destination and network manager.

*UPC/NPC(Usage Parameter Control /Network Parameter Control)* is to protect network resources from malicious and unintentional misbehaviour. They detect violations of negotiated traffic parameters and take actions such as discarding or marking violated cells.

*CAC(Connection Admission Control)* scheme must decide whether to accept or reject a new connection request considering the current network load, the available bandwidth, the traffic descriptor of the new connection request and its QoS requirements.

*Priority control* allows the user to generate different priority traffic flows by using the CLP bit. Low priority cells can

be discarded at a congested node.

*EDP/PPD(Early Packet Discard/Partial Packet Discard)* are two mechanisms that can be used on ATM connections that transport packets consisting of multiple ATM cells over a connection. Once a single cell has to be discarded, the whole PDU is immediately discarded.

*EFCI(Explicit Forward Congestion Indication)* can be triggered by a node when a congestion arrive at the node. In this case, the payload type field in the cell header is altered to inform the destination of the existence of a congestion.

Most available switches don't support all of the above traffic control schemes. A certain traffic control schemes can not be applied to a specific ATM switch.

<Table 1> shows some results of an experiment performed to measure the effectiveness of switch queuing algorithms for UBR(Unspecified Bit Rate) with TCP[ ]. A "Very low" in the excess bandwidth utilization column represent 0-20%, "High" 70-90%.

If traffic management is done right, ATM network can support traffic with varying performance requirements and, at the same time, it's bandwidth can be utilized effectively. The traffic management tools must be used carefully to be effective. But, when there are several



&lt;Table 1&gt; Effectiveness of switch queuing algorithms for UBR with TCP

Queuing Algorithm	Advantages and Disadvantages	Excess Bandwidth Utilization
Fifo queuing with EFCI	No fairness among the VCs Many VCs will experience 0% throughput due to beat down The feedback is insufficient The feedback depends upon the round-trip time	Very low
Per VC accounting with EFCI	Fairness among VCs Congestion on one VC can still affect other VCs The feedback is insufficient The feedback depends upon the round-trip time	Low
Per VC queuing with EFCI	Fairness among VCs Congestion is limited to each VC The feedback is insufficient The feedback depends upon the round-trip time	Medium
Per VC accounting with ER(Explicit Rate)	Fairness among VCs Congestion on one VC can still affect other VCs The feedback is efficient The feedback depends upon the round-trip time	Medium
Per VC queuing with ER	Fairness among VCs Congestion is limited to each VC The feedback is efficient The feedback depends upon the round-trip time	High
Per VC queuing with VS/VD	Fairness among VCs Congestion is limited to each VC The feedback is efficient The feedback is reduced to the time between VS/VDs	Very high

kind of switches in a network, the difficulties of maintaining the performance are multiplied. Therefore, it is certain that we need an intelligent performance manager.

**Switch management** is the area of handling OAM, traffic control, administration of a MIB(Management Information Base), usage measurement of the switch resources, etc.

Because there are wide spectrum of activities in that area, the switch management is not easy. The level of

management functions implemented in the switch is different for each switch. <Figure 5> and <Figure 6> show two examples of switch MIB. <Figure 5> shows the high level structure of the Cisco LS100 switch MIB. <Figure 6> is the structure of the Fore Switch MIB, where 250 objects are contained. Without seeing the technical details of the two switches, we can easily see that there are much of differences between the two switches.

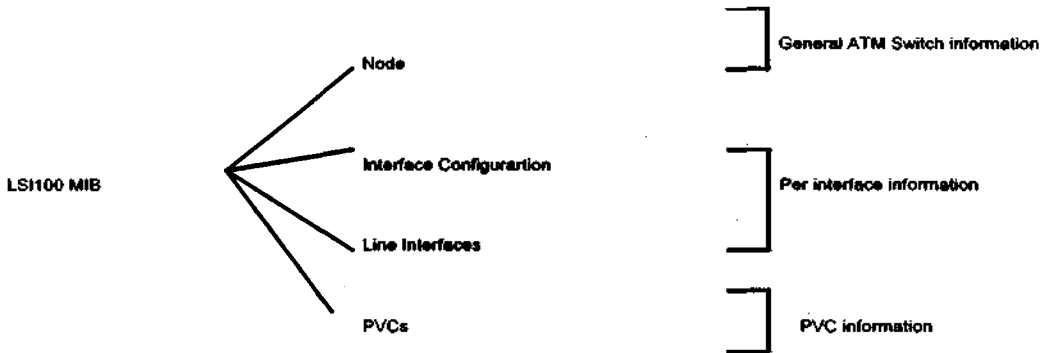

<Figure 5> Cisco LSI100 Switch MIB

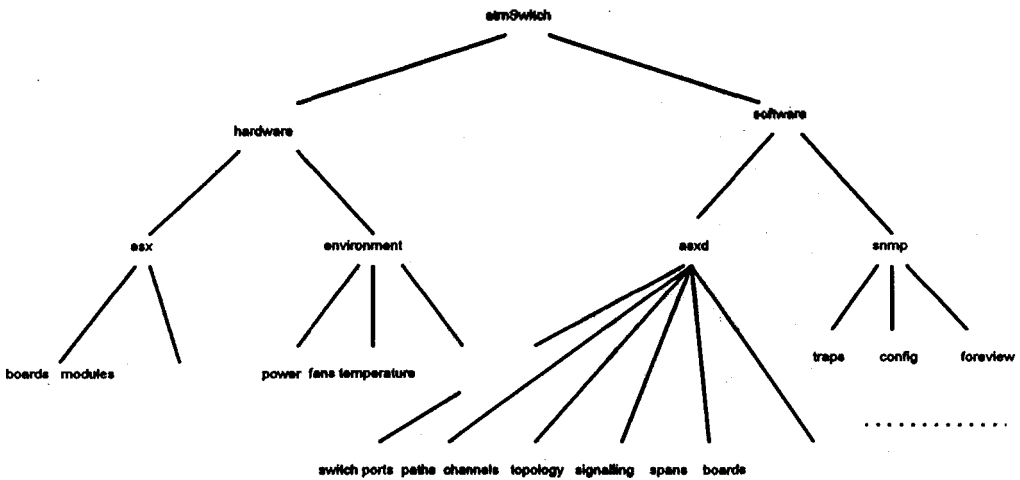

<Figure 6> Fore Switch MIB

#### 4. Integrated Performance Management Architecture

Managed objects are abstract representation of the network resources to be managed. These managed objects are under the control of agents, as described in <Figure 7>. The agent performs local management operations on the managed

objects on behalf of the manager and notifies the results to the manager. The manager and the agent are linked by SNMP(Simple Network Management Protocol) in our study.

CORBA(Common Object Request Broker Architecture) is defined by the OMG(Object Management Group) to provide a common architectural framework

for object-oriented applications. Users can access to information transparently with CORBA(For futher details about CORBA, refer to [12]). We use CORBA and its service specifications as base technology for implementing management applications, and existing management applications and agents. In our study, the management application and CORBA-SNMP gateway will be implemented in CORBA domain(see <Figure 8>).

The main duty of the gateway is to

translate the method invocation on an object references of MIB entries to SNMP messages to remote SNMP agent.

Monitoring and tuning the values of the parameters are our main concern in this study. Our goal is to introduce a framework through the proposal of a intelligent and integrated application model for network management. <Figure 9> shows our model for performance management application that are planned to be implemented.

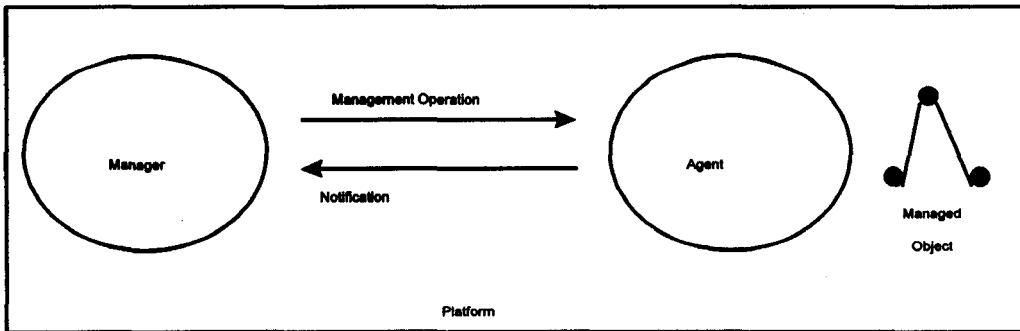

<Figure 7> Relationship between manager, agent and platform

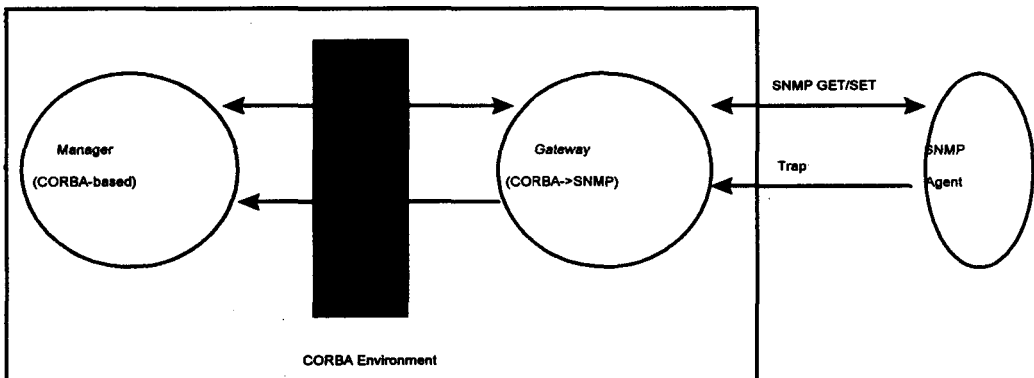

<Figure 8> Interaction between Gateway and CORBA-based Manager

The **Performance Model(PM)**'s duty is evaluating performance of the network. It calculates the optimum performance under specific conditions. For supporting the decision-making process(for example, capacity planning), we may need to calculate the optimum values of the performance parameters with artificial data. The analysis of the performance models of the computer networks may be performed by using one (or a combination) of the following three techniques: approximate analytical methods, exact analytical methods and simulation methods. We can choose a particular performance model for a protocol model considering the tradeoff between the computing time one wishes to spend on a model and the accuracy of the model. The analytical model reduces the accuracy and appropriateness of the model but requires less computing resources than the simulation model.

The **Management Information Base(MIB)** supports the integration and the management of network performance data. The integrated MIB memorizes three kinds of performance information about the corresponding subnetwork: static data, e.g. network configuration data; dynamic data, e.g. the values of QoS parameters(the cell transfer delay, the cell delay variation and the cell loss ratio); and statistical data, e.g. the mean

error rate for a certain period of time.

The **Intelligent Analyzer(IA)** module will use the performance models for calculating the optimum values of some performance parameters. But the real decisions about tuning is made by the IA module. The IA will find the cause of the problem by using an expertise. The IA can order more information to the **MONITOR** when the informations is not sufficient to decide an action. Depending on its degree of intelligence, the IA can solve the problem of performance by itself or in cooperation with the human manager. The knowledges which are included in KB are : basic knowledges about the protocols and the knowledges for problem recognition and solving.

The **Monitor** is working on the status of the networks to detect performance degradations. Its work is carried out in two ways: the polling of management agents of the subnetworks and the receipts of the reports from the management agents. The reports that come from an agent can be those generated by the agent on a regular basis or those generated incidentally when a threshold is reached. If a certain performance parameter value is out of the allowable range, the Monitor has to inform the intelligent analyzer of this problem.

**The Manufacturer's Access Interface**

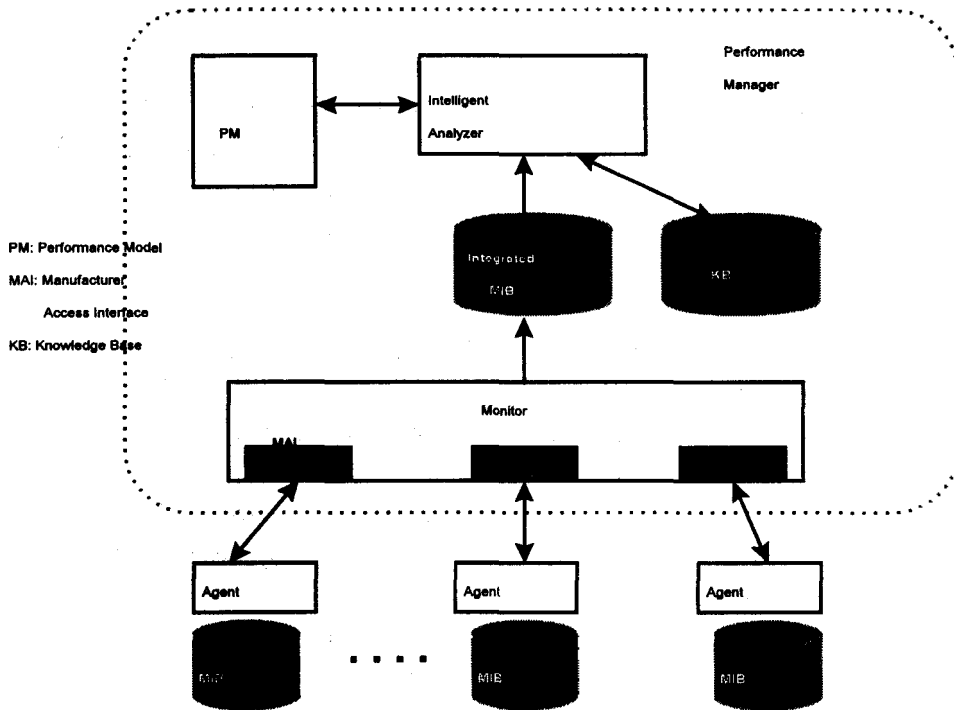

<Figure 9> Performance Management Architecture

(MAI) is composed of a physical access to a node or manufacturer management center, a logical access to a manufacturer administration, a syntax translation to provide a syntactic unification of the manufacturers' commands and a semantics translation of the manufacturers' management.

## 5. Conclusion

In ATM network, the network performance management activities do not deal with easy problems. It needs to solve the heterogeneity problems between

ATM switches made by different manufacturers. It is a good point if we can include the expertise of a human expert into the performance management application.

We have designed a performance management system for enterprise ATM network consisted of various kind of ATM switch. The system architecture and the relationships between the function blocks in the system have been described. The role of the performance evaluation model and other general requirements for performance management application in ATM network are discussed.

## Reference

- [1] H.I. Kwon, G. Pujolle, A. Tubtiang, "A Simple Flow Control Mechanism in ATM Network with End-to-end Transport", IEEE INFOCOM, San Francisco, pp. 654-661, 1993.
- [2] H.I. Kwon, G. Pujolle, "A Reactive Flow Control Mechanism in ATM Network with End-to-end Transport", IEEE FTDCS, Portugal, Sept. 1993.
- [3] H.I. Kwon, A. Tubtiang, G. Pujolle, "A Method for ATM Switch Classification", ICCT'92, Tech. Rep. MASI, Universite Paris 6, 1992.
- [4] R. Jain, "Congestion control and traffic management in ATM networks: Recent advances and a survey", Computer Networks and ISDN Systems 28, pp. 1723-1738, 1996.
- [5] G. Holliman, et al., "Customer Network Management", Data Communications International, Vol. 24, No. 15, October 1995.
- [6] Subrata Mazumdar, "Inter-Domain Management between CORBA and SNMP: WEB-based Management - CORBA/SNMP Gateway approach", DSOM'96, L'Aquila, Italy, October 1996.
- [7] D. Gaiti, G. Pujolle, "Performance Management Issues in ATM Networks: Traffic and Congestion Control", IEEE/ACM Transactions on Networking, Vol. 4, No. 2, April 1996.
- [8] ISO IS 7498-4, "Basic Reference Model - Part 4 - OSI Management Framework", August 1987.
- [9] ISO N4981, "Information Processing Systems-Open System Interconnection -Systems Management-Performance Management", July 1990.
- [10] Kornel Terplan, "Communication Networks Management", Prentice -Hall, 1987.
- [11] J.P. Claude et al, "Management of Open Networks in Heterogeneous Context", Proc. of the IFIP TC6/WG6,4a Int. Symp. on the management of Local Commun. Systems, Canterbury, U.K., Sep. 1991, pp. 81-100.
- [12] Jon Siegel, "CORBA Fundamentals and Programming", John Wiley & Sons, Inc., 1996.

## 저자소개

권혁인 (E-mail : hikwon9@unitel.co.kr)

(프랑스)파리6대학 통신공학 박사

현 중앙대학교 경영학과 교수

연구관심 분야 : 인터넷 비즈니스, 인터넷마케팅, 디지털 콘텐츠관리