

Mobile Robot with Artificial Olfactory Function

Jeong-Do Kim, Hyung-Gi Byun, and Chul-Ho Hong

Abstract: We have been developed an intelligent mobile robot with an artificial olfactory function to recognize odours and to track odour source location. This mobile robot also has been installed an engine for speech recognition and synthesis, and is controlled by wireless communication. An artificial olfactory system based on array of 7 gas sensors has been installed in the mobile robot for odour recognition, and 11 gas sensors also are located in the bottom of robot to track odour sources. 3 optical sensors are also included in the intelligent mobile robot, which is driven by 2 D.C. motors, for clash avoidance in a way of direction toward an odour source. Throughout the experimental trails, it is confirmed that the intelligent mobile robot is capable of not only the odour recognition using artificial neural network algorithm, but also the tracking odour source using the step-by-step approach method. The preliminary results are promising that intelligent mobile robot, which has been developed, is applicable to service robot system for environmental monitoring, localization of odour source, odour tracking of hazardous areas etc.

Keywords: artificial olfactory system, electronic nose, odour recognition and tracking

I. Introduction

There are much interesting to develop intelligent mobile robot that emulates the sense of human being. Most of researches for intelligent mobile robot have been concentrated with hearing and seeing using speech and/or image processing and synthesis techniques last decades. It made possible to colors recognition, component classifications, and distances measurements using image processing techniques. Also, the intelligent mobile robot has been developed to recognize approximate hundred words as speaker independently using speech recognition techniques. However, it has been difficult to find an intelligent mobile robot with an artificial olfactory function comparing with developed countries, even if the smelling is an important factor of human being.

For development of an intelligent mobile robot having an artificial olfactory system, it is essential to produce an artificial olfactory system. The gas chromatography (GC) has been used the odour monitoring system, which is large size analytical instrument and cost a great deal for purchase and operation. It has some limitations for intelligent mobile robot such as space, location problems, slow processing times, and interface with robot. The odour sensing system, which has small size and fast processing times, is more adaptable for interfacing with intelligent mobile robot.

The field showed little sign of advanced research before Moriizumis research group publication in the middle of 90s from Tokyo Institute of Technology [1][2]. They developed a mobile robot with plural gas and anemometric sensors to search for toxic gas leak location and an origin of a fire at its initial stage and the location of ethanol gas source. Russel et al have also demonstrated a robot system to locate hazardous

chemical leaks [3]. The mission of pathfinder from NASA was included a mobile robot to analysis odours in the Mars.

In present research, we have been developed an intelligent mobile robot with an artificial olfactory function to recognize odours and to track odour source location. This mobile robot also has been installed an engine for speech recognition and synthesis, and is controlled by wireless communication. An artificial olfactory system based on array of 7 gas sensors has been installed in the mobile robot for odour recognition, and 11 gas sensors also are located in the bottom of robot to track odour sources. 3 optical sensors are also included in the intelligent mobile robot, which is driven by 2 D.C. motors, for clash avoidance in a way of direction toward an odour source.

The overall system of intelligent mobile robot is controlled by a host processor and a sub-processor for olfaction and speech signal processing. The intelligent software is provided for odour recognition and tracking of odour source to an intelligent mobile robot. We adapted the Levenberg-Marquardt algorithm based on the back-propagation (LM-BP) [4], having more advantages then conventional multilayer perceptron neural network algorithms for the simultaneous classification and concentration estimation of odours. It could be possible to classify odour classification and to predict concentration levels simultaneously. In addition, the step-by-step progress method is applied to move the remote-control mobile stage iteratively in the direction of the odour source, which is detected by the sensor array.

An intelligent mobile robot with olfaction function, which also has approximately 20 words recognition ability, is called Think Nose.

II. Hardware configuration for intelligent mobile robot with olfactory function

1. Overall hardware configuration for intelligent mobile robot with olfactory function

An intelligent mobile robot, which has been developed and called Think Nose, is operated by Pentium III-500 Notebook computer as a main processor. The hardware incorporates a 80C196KC microcontroller based interface that controls sensors and motors in robot and then transfer data to a host Notebook computer for more advanced data analysis and control.

Manuscript received: Aug. 29, 2001., Accepted: Nov. 30, 2001.

Jeong-Do Kim: Dept. of Control & Instrumentation Engineering, Samchok National University

Hyung-Gi Byun: Dept. of Information & Communication Engineering, Samchok National University

Chul-Ho Hong: Dept. of Control & Instrumentation Engineering, Hoseo University

※ This work was supported by grant No.2000-1-30200-017-3 from the Basic Research Program of the Korea Science & Engineering Foundation. Dr. Hong gratefully acknowledges financial support from Hoseo University during his stay as a visiting professor at USA.

Figure 1 outlines system design based on a micro-controller interface and host computer. In addition, the real pictures of intelligent mobile robot, which has been developed, are shown in Figure 2.

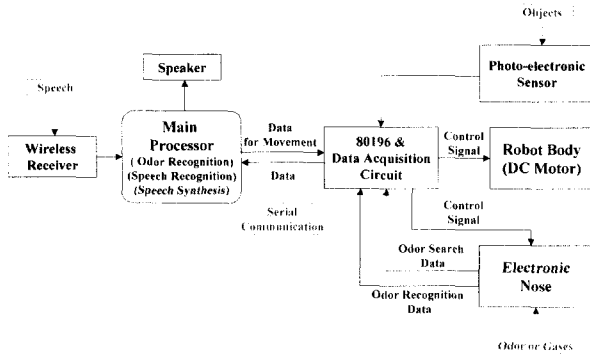
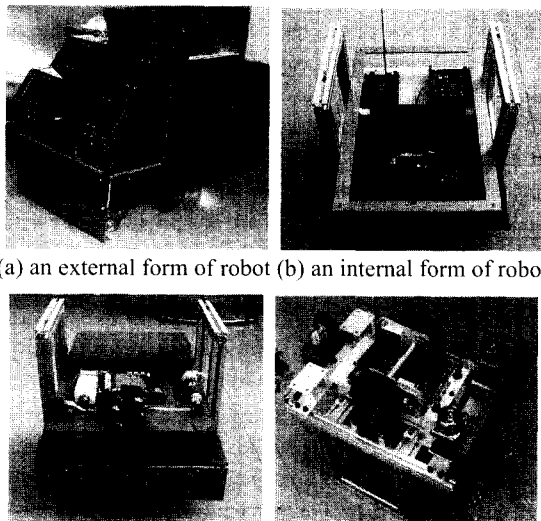

Fig. 1. A block diagram for hardware configuration of intelligent mobile robot.



(a) an external form of robot (b) an internal form of robot
(c) an electronic nose of robot (i.e. electronic nose) (d) bottom of robot

Fig. 2. Real pictures of intelligent mobile robot, which has been developed.

The system unit, which is motion control of robot and odour sensing system, is controlled by an embedded micro-controller 80C196KC working at 20MHz including A/D converters, allows the control of 8 independent channels. 7 independent channels are used for odour sensing system directly and 1 channel is used for odour tracking system with multiplexer. Communication between the micro-controller 80C196KC and host computer (i.e. Notebook computer) occurs via an RS-232 serial communication protocol. It can be said that micro-controller is working dependently with a host computer, which controls all operation process in real-time for mobile robot. The summary of hardware configuration for intelligent mobile robot with an olfactory function is as follows:

- ▶ Main Processor : Pentium III-500 Notebook computer
- ▶ Control and Data Acquisition : 80C196KC-20MHz
RAM-256Kbyte, ROM-256Kbyte, Multiplexer
- ▶ Olfactory Function (Electronic Nose)

- ▶ Odour recognition : An array of 7 Metal Oxide Gas Sensors (Figaro Inc, Japan)
- ▶ Odour tracking : 11 Metal Oxide Gas Sensors (Figaro Inc, Japan)
- ▶ Front Sensing System : FE7W-DA5K Optical Sensors
- ▶ Motor : 2 D.C. Motors
- ▶ Power : 24V Battery

2. Hardware configuration of olfaction function (Electronic Nose) in intelligent mobile robot

It is essential to install an artificial olfactory system (i.e. Electronic Nose) within the intelligent mobile robot. An artificial olfaction system with mobile robot has to have two different functions, which are odour recognition and tracking. An array of 7 different metal oxide gas sensors, which are manufactured by Figaro Inc. Japan, is used for odour recognition, and 11 gas sensors, which are same product from Figaro, are installed in the bottom of front side of robot to track odour sources.

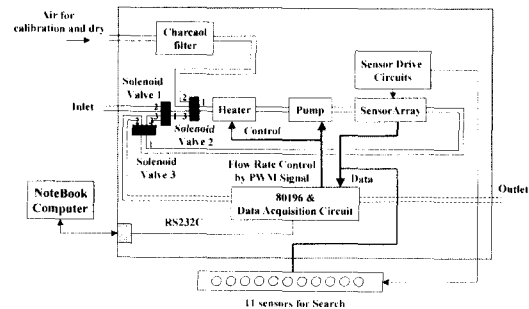

Fig. 3. Configuration of an artificial olfaction system.

The overall configuration of an artificial olfaction system, which is installed in mobile robot, is shown in Figure 3. As shown in the Figure 3, Dried air and sample odour are introduced into the multi sensor array alternatively using the three solenoid valves, which are usually used a 2-port 3-way type.

A small pump is presented to pull air and/or odour over the sensor array controlled from 0.5l/min to 2l/min flow rates by micro-controller.

To avoid temperature problems in the sensor array, the heating circuit is adapted to maintain constant temperature in the sensor array, which is also controlled by micro-controller with temperature sensor.

The filters, which are made by activated carbon and silicagel, remove impurity of odours and humidity from sampled air.

The data acquisition is carried out using 80C196KC micro-controller, which has 8-bit A/D converter for each channel. As we mentioned before, the overall system has 19 sensors, which is 7 sensors for odour recognition and 11 sensors for tracking odour sources. Therefore, 16 channel multiplexer is adapted for tracking function of odour sources, which does not need heavy calculations comparing with recognition.

The schematic diagram of the 80C196KC micro-controller functions for data acquisition is shown in Figure 4.

Table 1 presents the operation modes of artificial olfactory function for odour recognition in the intelligent mobile robot. The whole procedures for odour recognition, which is fol-

lowed by Table 1, could be taken approximately 70 seconds.

When the odour recognition is done, the odour source tracking operation can be carried out with intelligent mobile robot. 11 gas sensors, which are located in the bottom of mobile robot, are used for odour source tracking procedure.

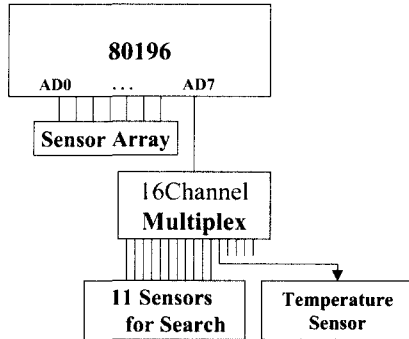

Fig. 4. Data acquisition for odours using 80C196KC micro-controller.

Table 1. The operation modes of artificial olfactory function for odour recognition.

Mode	Function (time)	Flow rate (l/min)
The initial cleaning mode	-Internal cleaning (20sec)	2
	-Zero calibration (5sec)	0.5
The absorption mode	-Gas Absorption (10sec)	0.5
The feedback mode	-Feedback for heating by constant temperature (30sec)	0.5
	-Data Acquisition(5sec)	
The cleaning mode	-Internal cleaning	2

III. Main processing algorithms for intelligent mobile robot with olfactory function

There are two main processing algorithms available to intelligent mobile robot with olfactory function, which are odour recognition and odour source tracking algorithms.

1. Odour recognition algorithm

A variety of pattern recognition techniques may be utilized for odour pattern classification. These include neural networks that take the input patterns generated by the array of sensors, and may be trained to associate these patterns with particular classes of volatile odours that may be of interest to the user. Such architectures include 3-layer systems trained by conventional back-propagation of error [5] and radial basis function network [6]. Of particular interest to us is not only the identification of odour classes, but also the prediction of odour concentration, even when the background may be complex. The quantification of odours is very desirable feature in real life and is much more difficult to predicted concentration levels of single chemicals or mixture than classification of different chemicals.

Most of researchers have tried to classify the odour identification and to predict concentration levels for odours separately using different algorithms. We have started to investi-

gated the properties of multilayer perceptron (MLP) for odour classification and concentration estimation simultaneously. When the MLP may he has a fast convergence speed with small error and excellent mapping ability for classification, it can be possible to use for classification and concentration prediction of odours simultaneously. However, the conventional MLP, which is back-propagation of error based on the steepest descent method, was difficult to use for odour classification and concentration estimation simultaneously, because it is slow to converge and may fall into the local minimum. We adapted the Levenberg-Marquardt algorithm based on back-propagation (LM-BP), having advantages both the steepest descent method and Gauss-Newton method instead of the conventional steepest descent method for the simultaneous classification and concentration estimation of odours. The basic network configuration of LM-BP algorithm is shown in Figure 5. The update rule for LM-BP algorithm is as follow[7]

$$\omega_{m+1} = [J^T(\omega_m) J(\omega_m) + \lambda_m I]^{-1} J^T(\omega_m) e(\omega_m)$$

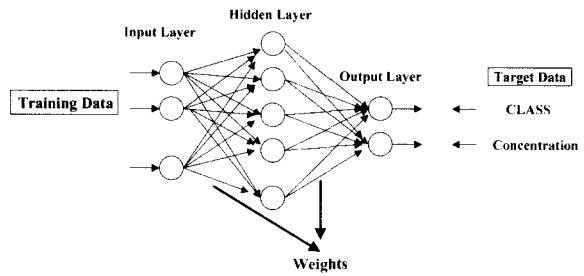

Fig. 5. The Multilayer perceptron network basic configuration for odour classification and concentration estimation using LM-BP algorithm.

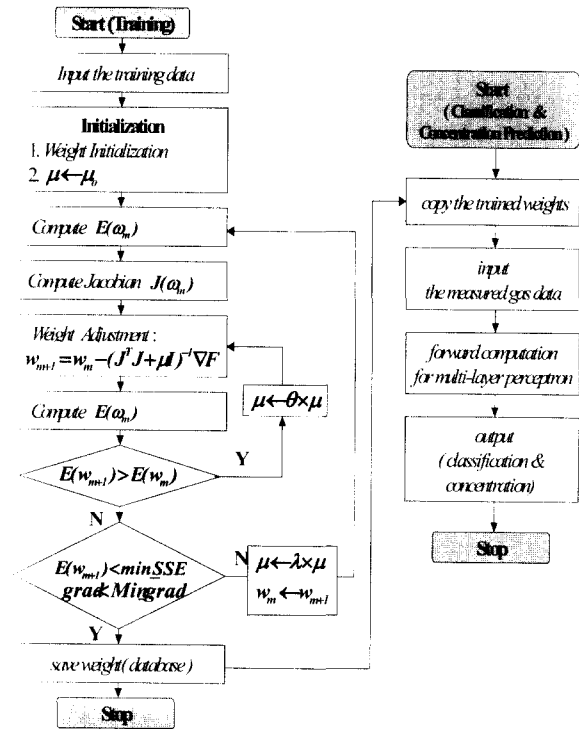

Fig. 6. A simple flow chart for LM-BP algorithm procedure.

Where J is the Jacobian matrix of derivatives of each weight, λ is a scalar, and e is an error vector. $J^T J$ is called the Hessian matrix and $J^T e$ is the gradient. The training is carried out by steepest descent method when λ is large, the Gauss-Newton method is used for training when λ is small. Using the above updating rule, the LM-BP algorithm is carried out training and testing procedure such as flowchart shown at Figure 6.

2. Odour source tracking algorithm

It could be difficult to track odour source with intelligent mobile robot, because the electrochemical sensor was usually shown slow response to odour detection and the diffusion speed of odour was faster than sensors electrical response time. We have been installed 11 gas sensors in the bottom of mobile robot for odour source tracking procedure. Each sensor has 3cm distance between them at the horizontal way. The sensors are calibrated to show same responses to the same concentration, it can be possible to move the mobile robot toward the direction of odour source where the concentration is high.

However, it still has some problems to track odour source using the intelligent mobile robot. One of problem is that a fault tracking is possible cause of variation of odour concentration levels. When the sensors detect the high concentration position of odour source, the direction of high concentration is moved to the previous position due to sensor response times. In addition, some gas sensors still has small particles of the previous detected odour, even if the refreshment procedure is done. Therefore, we calibrated sensors sensitivities were worked sensitive as 10 ppm alcoholic vapour, and the odour concentration levels, which is indicated to direction of odour source, is calculated not only the present concentration levels but also the previous concentration levels.

The intelligent mobile robot is not moved to track odour source continuously but remaining one and half seconds after movement to find high odour concentration level. Also, it is moved only 30cm once according to the odour concentration levels. When the variation of sensor response is almost nothing following by times, the robot is moved to same direction. When each sensor is shown a tiny variation value, the mobile robot is moved to reverse direction to avoid missing positions. The tracking of odour source algorithm for an intelligent mobile robot is summarized as follows:

```
void RobotOdorSearch(void)
{
do {
wait_odor(1.5);
dmlargenum=DmLargeValue();
// The largest variations between the present
// variation and the previous variation
largenum=LargeValue();
// The largest variation values among the present
// variation values, which indicate the robot moving
// direction

if((sen_val[dmlargenum]>=10)&&(dmlargenum==largenum))
turn=dmlargenum;
```

```
else if( sen_val[history_max]>sen_val[dmlargenum] )
turn=12;
else if(sen_val[dmlargenum]>=10 ) turn=dmlargenum;
else if(sen_val[dmlargenum]<=-2) turn=11;
} while( OdorSearchCommand != SERACH_STOP )
}
```

VI. Experimental results

We have been carried out experimental trails to recognize odours and to track odour source location using an intelligent mobile robot, which has been developed.

The whole procedures for odour recognition could be taken approximately 70 seconds, and the tracking of odour source would be taken 2 min 15 sec, respectively.

The experimental trails were carried out independently.

1. Odour recognition experimental results

We tested the performance of LM-BP algorithm for odour recognition problem using a series of nine odourant liquids wine, whisky, methanol, trichloroethylene, mouth washer, benzen, vinegar, acetone, perfume. The responses of individual sensors, which could represented detected odours, were applied as input patterns to the recognition algorithm. Odour recognition experiments were carried out to establish whether a LM-BP algorithm could be trained successfully to recognize each pattern of odours to determine the extent of which the output values converges to the desired values, and the ability of network to classify the odours.

The input layer possesses seven processing elements according to number of sensors. This input layer is fully connected to the hidden layer. The number of hidden layers and processing elements could be selected to accelerate and improve the convergence performance in the training process. One hidden layer and 35 hidden processing elements, which were found to give good results experimentally, were used. Finally, the output layer contains two processing elements, which were class index and concentration level.

Table 2. Odour recognition testing result for nine different odourant liquids using an intelligent mobile robot.

	1st	2nd	3th	4 th	5th
whisky	1.08 o	1.11 o	1.21 o	1.15 o	1.36 o
wine	2.01 o	2.08 o	2.14 o	2.17 o	2.25 o
perfume	3.24 o	3.35 o	3.42 o	3.48 o	3.53 ×
mouth washer	4.02 o	4.08 o	4.05 o	4.16 o	4.26 o
methanol	5.12 o	5.17 o	5.21 o	5.32 o	5.39 o
acetone	6.14 o	6.19 o	6.18 o	6.26 o	6.33 o
benzene	7.18 o	7.24 o	7.29 o	7.44 o	7.51 ×
trichloroethylene	8.07 o	8.18 o	8.32 o	8.45 o	8.49 o
vinegar	9.11 o	9.16 o	9.37 o	9.24 o	9.63 ×

whisky: 1. wine: 2. perfume: 3. mouth washer: 4
methanol: 5. acetone: 6. benzen: 7. trichloroethylene: 8
vinegar: 9

o : success × : failure

The response patterns obtained from experimental measurement using an intelligent mobile robot were prepared for training and testing data sets. The training data sets were prepared 27 patterns from the nine different odours following by 3 times measurements. The trained system was then tested against 45 patterns following by 5 times measurements.

The table 2 indicated the recognition result for testing data sets using LM-BP algorithm, which we adapted only classification ability from the algorithm to intelligent mobile robot implementation in this paper.

It illustrated test data sets, which were not seen the training session, were well recognized with 93.3% success rate using the previously trained weights. It should mentioned that the success rate of recognition was kept 100% until 4th testing data sets, but it went down to 93.9% success rate at 5th data set. It indicated that the remaining odours have to remove as clear as possible when the new measurement is started.

2. Odour source tracking experimental results

When the odour recognition was done, the odour source tracking operation could carried out using an intelligent mobile robot. For this experiment, we had to constructe 3.4m X 3.4m local space for robot moving area and spread wine, which was the target odour source to track, using a syringe. The experiment was carried out to move the robot direction of odour source, which was detected by the 11 gas sensors in the bottom of robot.

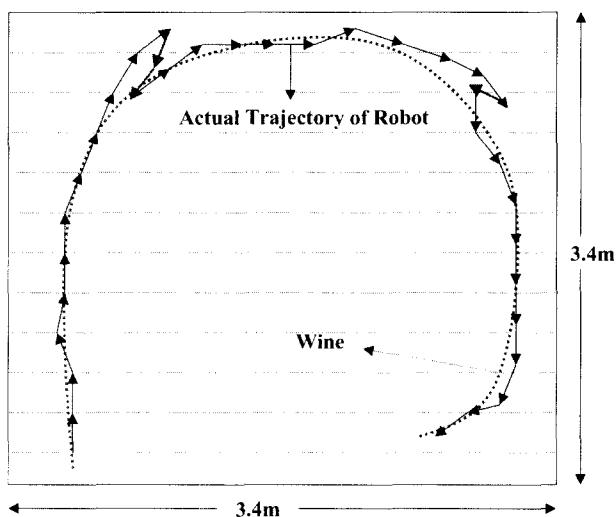

Fig. 7. The experimental result for tracking odour source using an intelligent mobile robot, which has been developed.

The result of the tracking process is shown in Figure 7. The dot-line is shown the tracks of actual odour direction. The direction toward the odour source was determined using the present values of the sensor outputs as well as the previous

values of the sensor outputs. The solid-line with arrows is shown the actual trajectory of intelligent mobile robot for odour source tracking.

In the top left and top right region of given track, the actual trajectory was shown much deviated. It can be explained that robot was moved to reverse direction to avoid missing positions when each sensor was shown a tiny variation value.

The tracking result, which was shown in Figure 7, was satisfied, even if the time was spent approximately 2 minutes 15 seconds to track odour source.

V. Conclusions

An intelligent mobile robot having an artificial olfactory function has been developed for odour recognition and tracking odour source.

Throughout the experimental trails, it is confirmed that the intelligent mobile robot is capable of not only the odour recognition using artificial neural network algorithm, but also the tracking odour source using the step-by-step approach method. Although the conditions of experimental trails were poor and limited, these preliminary results are promising that intelligent mobile robot, which has been developed, is applicable to service robot system for environmental monitoring, localization of odour source, odour tracking of hazardous areas etc.

However, it is still far from human-like service robot system, it may be possible in the future to associate advanced machtronics technologies having human opinion.

References

- [1] H. Ishida, K. Suetsuga, T. Nakamoto, and T. Moriizumi, Study of autonomous mobile sensing system for localization of odor source using gas sensors and anemometric sensors, *Sensors & Actuators A* 45, pp. 153-157, 1994.
- [2] H. Ishida, T. Nakamoto, and T. Moriizumi, Remote sensing of gas/odor source location and concentration distribution using mobile system, *Sensors & Actuators B* 49, pp. 52-57, 1998.
- [3] R.A. Russel, D. Thiel, R. Deveza, and A. Mackay-Sim, A robotic system to locate hazardous chemical leaks, *Proc. IEEE Int. Conf. Robotics and Automation*, Nagoya, Japan May pp. 556-561, 1995.
- [4] T. Master, *Advanced algorithms for neural networks*, Wiley, pp. 47-71, 1995.
- [5] D. Rumelhart, G.E. Hinton, and R.J. Williams, Learning representation by error propagation, *Nature*, vol. 323, pp. 533-536, 1986.
- [6] H. Byun, K.C. Persaud, J. Kim, and D. Lee, Improvement RBF Networks performance for application to odour sensing system, *Proc. ISOEN99*, Tübingen, Germany, Sep. pp. 237-240, 1999.
- [7] J. Kim, H. Byun, and K.C. Persaud, Application of a multilayer perceptron based on the Levenberg-Marquardt algorithm to odour pattern classification and concentration estimation using odour sensing system, *Proc. ISOEN20*



Jeong-Do Kim

Jeong-Do Kim received his BS and MS degree in Electronic engineering from Sungkyunkwan University in 1987 and 1990. He received his Ph.D in Electronic engineering from Sungkyunkwan University in 1994. Since 1995, he has been with the Department

of Control and Instrumentation Engineering, Samchok National University, where he is currently an Associate Professor. He research interests include intelligent control and signal processing based Neural network and Genetic algorithm, intelligent robot with electronic nose



Chul-Ho Hong

Chol-Ho Hong was born in Chong Ju , Korea in 1954. He received B.S, M.S, and Ph.D degrees in 1977,1982,and 1989, respectively, from the Department of Electronics Engineering of Sung KyunKwan university. Since 1989, he has been with the Department of

Control and Instrumentation Engineering, Hoseo University, where he is currently an Professor. His research interests are applications of sensor and automatic control, control of Robot systems



Hyung-Gi Byun

Hyung-Gi Byun received the BS degree in Electric engineering from Myungji University in 1984, Msc Degree in electrical engineering and Electronics, and Ph.D in Instrumentation and Analytical Science from University of Manchester Institute of Science and

Technology(UMIST), U.K. in 1990 and 1995. He joined the Department of Information and Communication Engineering, Samchok National University, where he is currently an assistant professor with interest in pattern recognition and signal processing based on artificial neural network. He specializes in electronic nose technology, which include hardware and software implementation of sensing system.