

Efficient Iris Recognition through Improvement of Feature Vector and Classifier

Shinyoung Lim, Kwanyong Lee, Okhwan Byeon, and Taiyun Kim

In this paper, we propose an efficient method for personal identification by analyzing iris patterns that have a high level of stability and distinctiveness. To improve the efficiency and accuracy of the proposed system, we present a new approach to making a feature vector compact and efficient by using wavelet transform, and two straightforward but efficient mechanisms for a competitive learning method such as a weight vector initialization and the winner selection. With all of these novel mechanisms, the experimental results showed that the proposed system could be used for personal identification in an efficient and effective manner.

I. INTRODUCTION

To control the access to secure areas or materials, a reliable personal identification infrastructure is required. Conventional methods of recognizing the identity of a person by using passwords or cards are not altogether reliable, because they can be forgotten or stolen. Biometric technology, which is based on physical and behavioral features of human body such as face, fingerprints, hand shape, eyes, signature and voice, has now been considered as an alternative to existing systems in a great deal of application domains. Such application domains include entrance management for specified areas, and airport security checking system.

Among various physical characteristics, iris patterns have attracted a lot of attention for the last few decades in biometric technology because they have stable and distinctive features for personal identification. That is because every iris has fine and unique patterns and does not change over time since two or three years after the birth, so it might be called as a kind of optical fingerprint [1], [2]. Figure 1 shows an image of human iris pattern.

Most works on personal identification and verification using iris patterns have been done in the 1990s [4]-[8]. Through these works, we could achieve a great deal of progress in iris-based identification systems much more than we expected. Some work, however, has limited capabilities in recognizing the identity of person accurately and efficiently, so there is much room for improvement of some technologies affecting performance in a practical viewpoint. The main difficulty of human iris recognition is that it is hard to find apparent feature points in the image and to keep their representability high in an efficient way. In addition, the identification or verification process suitable for iris patterns is required to get high accuracy.

Manuscript received May 8, 2000; revised May 2, 2001.

Shinyoung Lim is with the Electronic Payment Team, ETRI, Taejeon, Korea. (phone: +82 42 860 5015, e-mail: sylim@econos.etri.re.kr)

Kwanyong Lee is with the Yonsei University, Seoul, Korea.

(phone: +82 11 550 3683, e-mail: kylee@csai.yonsei.ac.kr)

Okhwan Byeon is with the KISTI, Taejeon, Korea.

(phone: +82 42 869 0570, e-mail: ohbyeon@garam.kreonet.re.kr)

Taiyun Kim is with the Korea University, Seoul, Korea.

(phone: +82 2 3290 3194, e-mail: tykim@netlab.korea.ac.kr)

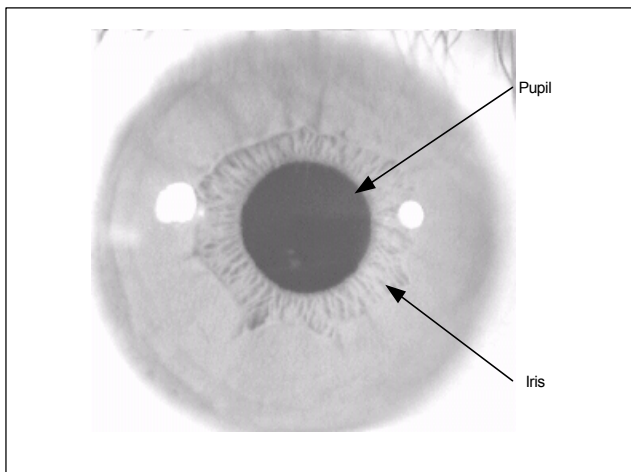

Fig. 1. An image of human iris.

In this paper, we propose some optimized and robust methods for improving the performance of human identification system based on the iris patterns from the practical viewpoint. To achieve better performance of iris-based identification systems by proposing some efficient methods, we conduct the following experiments: the performance evaluation of the popular feature extraction methods – Gabor transform and Haar wavelet transform – to select a good method suitable for iris patterns, the performance comparison according to the dimension of a feature vector to make a feature vector compact, and the performance comparison of a competitive learning neural network by adding revised mechanisms for the initialization of weight vectors and the winner selection. Through various experiments, we show that the proposed methods can be used for personal identification systems in an efficient way.

The contents of this paper are as follows. In the following section, some related works are briefly mentioned. Section III gives the details of the proposed method for extracting features and recognizing them. Experimental results and analyses will be stated in Section IV, and finally the conclusions are given in Section V.

II. RELATED WORKS

In the process of the iris recognition, it is essential to convert an acquired iris image into a suitable code that can be easily manipulated. Thus, we will take a brief look at the process of feature extraction and representation from the recent remarkable works.

Daugman [4] developed the feature extraction process based on information from a set of 2-D Gabor filter. He generated a 256byte code by quantizing the local phase angle according to

the outputs of the real and imaginary parts of the filtered image, comparing the percentage of mismatched bits between a pair of iris representations via XOR operator, and selecting a separation point in the space of Hamming distance.

On the contrary, the Wildes system made use of Laplacian pyramid constructed with four different resolution levels to generate iris code [7]. It also exploited a normalized correlation based on goodness-of-match values and Fisher's linear discriminant for pattern matching. Both iris recognition systems make use of bandpass image decompositions to get multi-scale information.

Boles [8] implemented the system operating the set of 1-D signals composed of normalized iris signatures at a few intermediate resolution levels and obtaining the iris representation of these signals via the zerocrossing of the dyadic wavelet transform. It made use of two dissimilarity functions to compare the new pattern with the reference patterns.

Boles' approaches have the advantage of processing 1-D signals rather than 2-D image used in both [4] and [7]. However, [4] and [7] proposed and implemented a whole system for personal identification or verifications including the configuration of image acquisition device, but [8] only focused on the iris representation and matching algorithm without an image acquisition module.

In this paper, we propose an iris recognition system which includes a compact representation scheme for iris patterns by the 2-D wavelet transform, a method of initializing weight vectors, and a method of determining winners for recognition in a competitive learning method like LVQ.

III. ANALYSIS AND RECOGNITION OF IRIS IMAGE

The overall structure of the proposed system is illustrated in Fig. 2, and its processing flow is as follows. An image surrounding human eye region is obtained at a distance from a CCD camera without any physical contact to the device. In the preprocessing stage, the following steps are taken. First, we should localize an iris, the portion of the image to be processed actually. Second, Cartesian coordinate system of the image is converted into the polar coordinate system so as to facilitate the feature extraction process. In the feature extraction stage, 2-D wavelet transform is used to extract a feature vector from the iris image. In the final stage, the identification and verification stage, two revised competitive learning methods for LVQ are exploited to classify the feature vectors and recognize the identity of person. In order to improve the efficiency of the system, some methods are applied to the feature extraction stage and the identification stage.

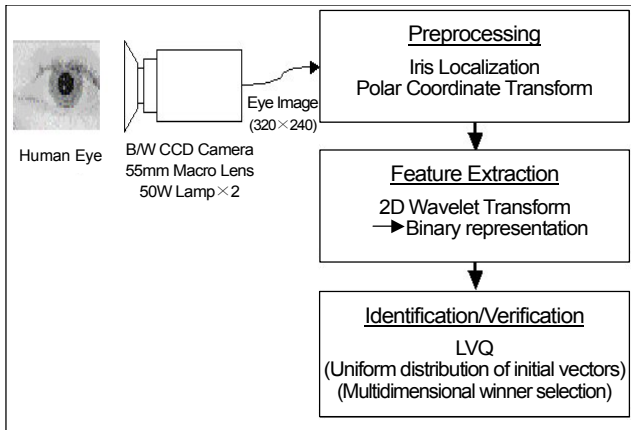

Fig. 2. Structure of the proposed iris recognition system.

1. Image Acquisition

An image surrounding human eye region is obtained at a distance from a CCD camera without any physical contact to the device. Figure 3 shows the device configuration for acquiring human eye images. To acquire more clear images through a CCD camera and minimize the effect of the reflected lights caused by the surrounding illumination, we arrange two halogen lamps as the surrounding lights, as the figure illustrates. The size of the image acquired under this circumstances is 320x240.

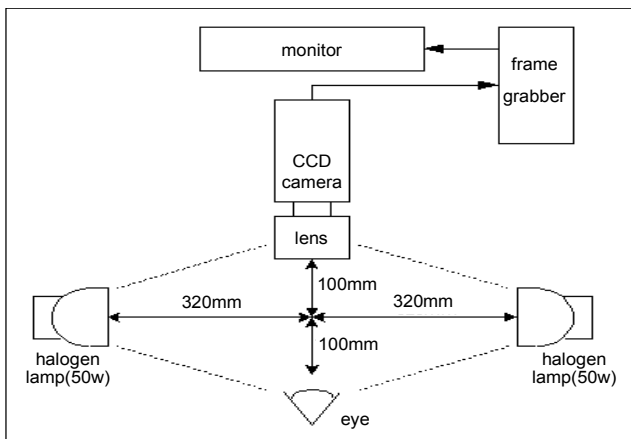

Fig. 3. Configuration of the proposed image acquisition device.

2. Preprocessing Stage

In this stage, we should determine an iris part of the image by localizing the portion of the image derived from inside the limbus (outer boundary) and outside the pupil (inner boundary), and finally convert the iris part into a suitable representation.

To localize an iris, we should find the center of the pupil at first, and then determine the inner and outer boundaries. Because there is some obvious difference in the intensity around each boundary, an edge detection method is easily applied to acquire the edge information. For every two points of the edge that may be regarded as the inner boundary by some prior knowledge of the images, we apply the bisection method to determine the center of the inner boundary, which is also used for the reference point of the following processes. By applying the bisection method to every two points on the same edge, we can get only one point in the ideal case which crosses every perpendicular line over the line connecting to two points, but actually we cannot obtain only one point so we select the center point as the most frequently crossed point.

After determining the center point, we find the inner boundary and the outer boundary by extending the radius of a virtual circle from the center of pupil and counting the number of points of the edge on the corresponding virtual circle. Two virtual circles with the maximum number of points of the edge within each corresponding range determined by some prior knowledge are selected as the two boundaries that we want to find. Figure 4 shows the center of the pupil and the iris part surrounded by two boundaries.

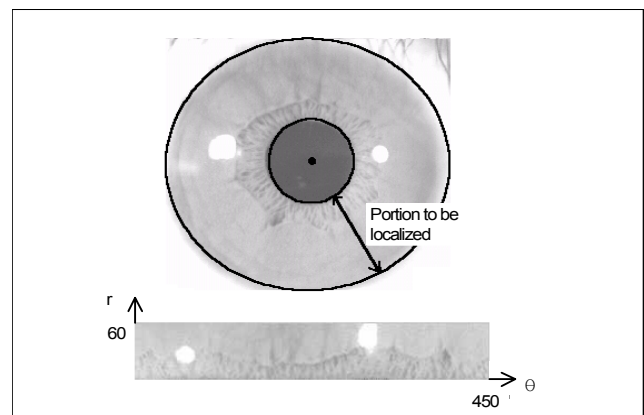

Fig. 4. Example of results in the preprocessing stage.

The localized iris part from the image is transformed into polar coordination system in an efficient way so as to facilitate the next process, the feature extraction process. The portion of the pupil is excluded from the conversion process because it has no biological characteristics at all. The distance between the inner boundary and the outer boundary is normalized into $[0, 60]$ according to the radius r . By increasing the angle θ by 0.8° for an arbitrary radius r , we obtain 450 values. We, therefore, can get a 450×60 iris image for the plane (θ, r) . Figure 4 shows the process of converting the Cartesian coordinate system into the polar coordinate system for the iris part.

3. Feature Extraction Stage

Gabor transform and wavelet transform are typically used for analyzing the human iris patterns and extracting feature points from them [4], [9]-[11]. In this paper, a wavelet transform is used to extract features from iris images. Among the mother wavelets, we use Haar wavelet illustrated in Fig. 5 as a basis function.

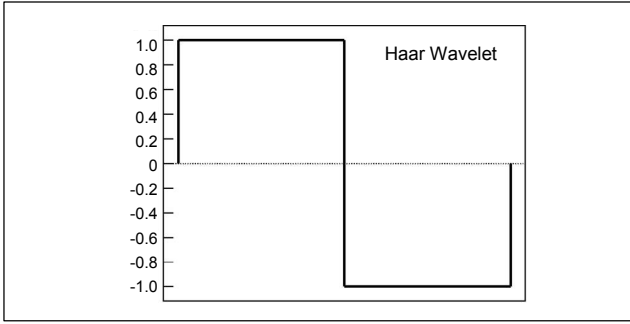

Fig. 5. Haar Mother Wavelet.

Figure 6 shows the conceptual process of obtaining the feature vectors with the optimized dimension. Here, H and L mean the high-pass filter and the low-pass filter, respectively, and HH indicates that the high-pass filter is applied to the signals of both axes. For the 450×60 iris image obtained from the preprocessing stage, we apply wavelet transform four times in order to get the 28×3 sub-images. Finally, we organize a feature vector by combining 84 features in the HH sub-image of the high-pass filter of the fourth transform (HH_4 of Fig. 6) and each average value for the three remaining high-pass filter areas (HH_1 , HH_2 , and HH_3 in Fig. 6). The dimension of the resulting feature vector is 87.

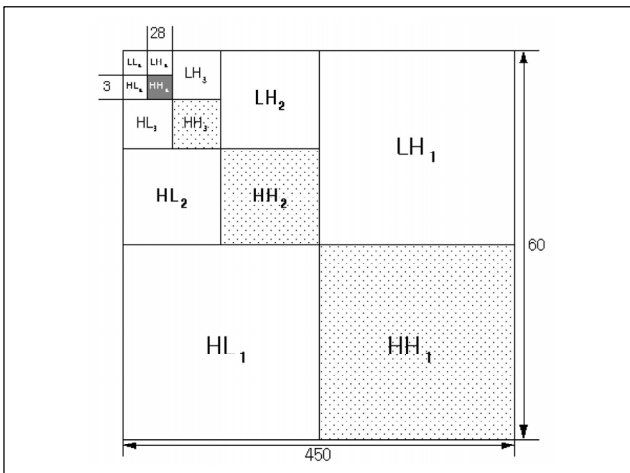

Fig. 6. Conceptual diagram for organizing a feature vector.

Each value of 87 dimensions has a real value between -1.0 and 1.0 . To reduce space and computational time for manipulating the feature vector, we quantize each real value into binary value by simply converting the positive value into 1 and the negative value into 0. Therefore, we can represent an iris image with only 87 bits.

4. Identification and Verification Stage

In general, the competitive learning neural network like LVQ has the faster learning mechanism than the error backpropagation algorithm but its performance is easily affected by initial weight vectors [12], [13].

To solve such a problem for at least iris patterns, a new method for initializing the weight vectors in an effective manner is proposed. This method generates the initial vectors that can be located around the boundary of each class. In the learning process, the common learning process for LVQ is accomplished after initializing the weight vectors by the proposed method. In the recognition process, we set the acceptance level and use it to determine whether the final result is accepted or rejected [15], [16].

The process of the proposed initialization algorithm called the uniform distribution of initial weight vectors is as follows. (see Fig. 7)

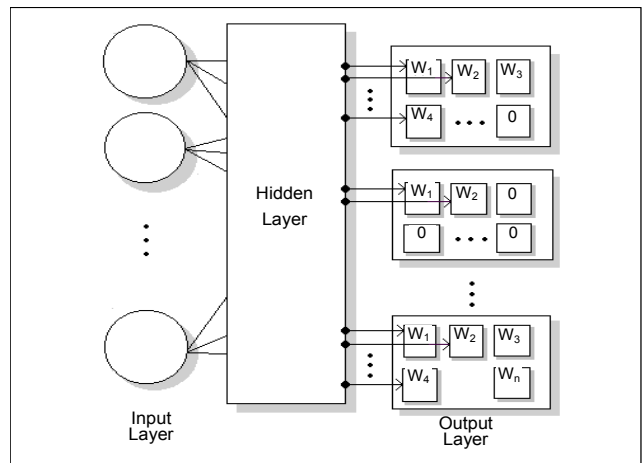

Fig. 7. Concept of the uniform distribution of initial weight vectors.

Step 1 Set initial weight vectors with the vector of the first learning pattern of each class and other weight vectors to be zero.

$$W_1^k = X_1^k \quad \text{for } k = 1, 2, \dots, M \quad (1)$$

where

X_1^k : the vector of the first learning pattern of the k-th class.

W_1^k : the first weight vector of the k-th class.

M : the number of class.

Step 2 Select another pattern of each class as a new learning pattern.

Step 3 Calculate the distance d_j between the learning pattern and the weight vector by the following equation.

$$d_j^2 = \sum_{i=0}^{N-1} (X_{ip}^k - W_{ij}^k)^2 \quad (2)$$

where

X_{ip}^k : the i-th component of p-th learning pattern of k-th class.

W_{ij}^k : the i-th component of the j-th weight vector of k-th class.

N : the dimension of a learning pattern.

Step 4 Determine whether the class of the weight vector with the minimum distance among all d_j is equal to the class of the learning pattern. If the class of the weight vector is not equal to the class of the learning pattern, then add the vector of the learning pattern as a new weight vector.

Step 5 Go to step 2 until all of the learning patterns are used in the learning process.

The winner selection method based on Euclidean distance that is generally used in competitive learning neural networks has no problem in determining the minimum distance of each class, as a whole. However, if the dimension of a feature vector increases, so does the possibility of selecting a wrong winner because of the failure of obtaining the information on each dimension. To solve such a problem, a new algorithm of winner selection called multidimensional winner selection method is proposed. The proposed algorithm is to determine the winner of each dimension, count the frequency of becoming the winner according to each class, and then select a class with the largest value as the final winner. Figure 8 shows the conceptual diagram of the proposed winner selection method. In the figure, each plate in a neuron indicates each dimension of a feature vector.

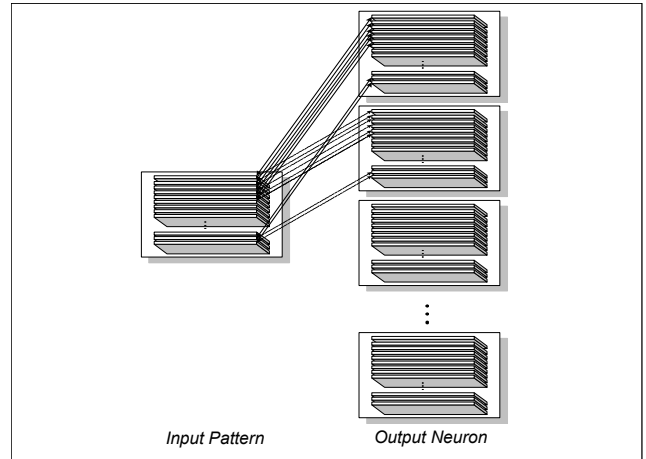

Fig. 8. Conceptual diagram of multi-dimensional winner selection method.

IV. EXPERIMENTAL RESULTS

To evaluate the performance of the proposed human iris recognition system, we collected 6,000 data acquired from 30 images per people for 3 months with the help of volunteers of 200 Korean university students, who are in their early twenties. The environment of image acquisition is illustrated in Fig. 2. The parameters used in LVQ such as the learning rate and the iteration number are shown in Table 1. The learning rate is a constant that decreases from 1 to near 0 as learning is processed. And the iteration number is 't' in Table 1.

Table 1. Parameters for LVQ.

Initial learning rate	0.1
Update of learning rate	$\alpha(t) = \alpha(0) \left(1 - \frac{t}{\text{total number of iteration}} \right)$
Total iteration	300

Under the experimental environments above, we have conducted two kinds of experiments: one is to see the performance of each method proposed in this paper, and the other is to provide two kinds of error rates such as false accept rate (FAR) and false reject rate (FRR).

1. Results on Preprocessing Stage

In the experiments for the preprocessing stage, we checked the accuracy of the boundaries subjectively and obtained the

success rate of 88.2% (5,292 data) on 6,000 data. Table 2 shows the causes of the failure of preprocessing. As you can see the table, the remarkable thing is that the failure of data with glasses takes 18.8 % over the total failure.

Table 2. Analysis of the failure of preprocessing according to the causes.

Cause of Failure		# of Data	Ratio (%)
Data without Glasses and with Lens	(1) Occlusion by eyelids	178	31
	(2) Inappropriate eye positioning	127	22
	(3) Shadow of eyelids	121	21
	(4) Noises within pupil	34	6
	(5) Etc	115	20
	Total	575	100
Data with Glasses	(6) Noises or dirt on the glasses	49	37
	(7) Reflection of glasses	28	21
	(8) Shadow of the rim of glasses	20	15
	(9) Etc	36	27
	Total	133	100

Figure 9 shows the examples of the failure in the preprocessing stage according to the causes. Each number of the figure corresponds to the cause of Table 1.

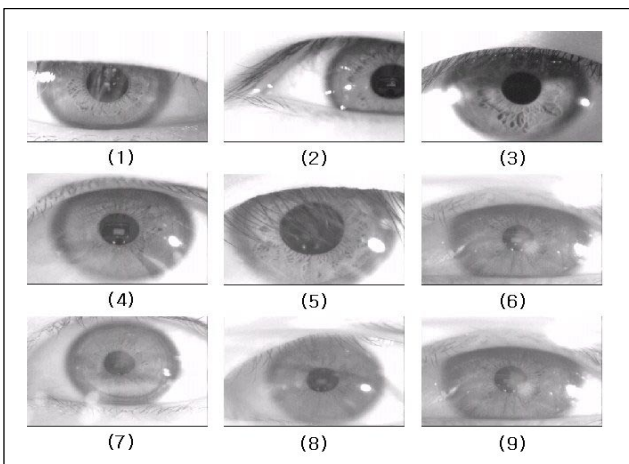

Fig. 9. Examples of the failure in the preprocessing stage.

Also, we can see that the success rate for data with glasses in the preprocessing stage is about 10% less than that of other data without glasses or with lens.

2. Performance Comparison of Individual Method

A half of 5,292 data that are obtained successfully from the preprocessing stage are used as the learning data for LVQ, and the remaining half as the test data. The following subsections describe the results on each stage or method proposed in this paper.

A. Feature Extraction Method

Table 3 shows the recognition rate on two different feature extraction methods, Gabor transform and Haar wavelet transform, with the same classifier. The recognition rate of wavelet transform is better than that of Gabor transform by 0.9% and 2.1% for the learning data and test data, respectively. Therefore, we used Haar wavelet transform as the basis of feature extraction method in the following experiments.

Table 3. Comparison of two feature extraction methods.

	Gabor Transform	Wavelet Transform
Learning Data	95.3%	96.2 %
Test Data	92.3 %	94.4 %

B. Weight Vector Initialization Method

Table 4 shows the results on the accuracy comparison of two initialization methods under the same experimental environments. In the case of the proposed method called the uniform distribution of initial weight vectors, the experimental results on both the learning data and the test data showed better performance than those of the initialization with random values which is regarded as a basic initialization method.

Table 4. Comparison of weight vector initialization methods.

	Initialization with random values	Proposed method
Learning Data	96.2 %	97.1 %
Test Data	94.4 %	95.9 %

C. Winner Selection Method

Table 5 shows the experimental results on two methods of winner selection when we use Haar wavelet transform for feature extraction and LVQ with the proposed initialization method. You can see that the proposed method, the multidimensional method showed a good result for human iris features.

Table 5. Comparison of winner selection methods.

	Euclidean distance method	Multi-dimensional method
Learning Data	97.1 %	97.8 %
Test Data	95.9 %	97.2 %

D. Size of Feature Vector

From the three experimental results above, we selected each method with high accuracy to configure a good system for personal identification based on iris patterns. The selected methods for each stage are as follows; Haar wavelet transform for feature extraction, uniform distribution method for initializing weight vectors, and multidimensional method for winner selection.

With the iris recognition system composed of these methods, we try to minimize or optimize the dimension of feature vector

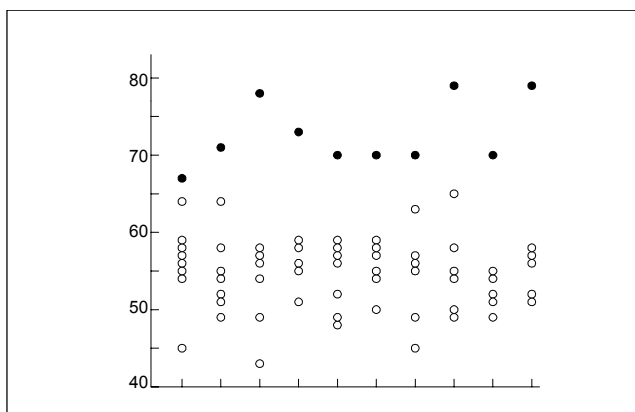

Fig. 10. Degree of match by 87 dimensions for a feature vector.

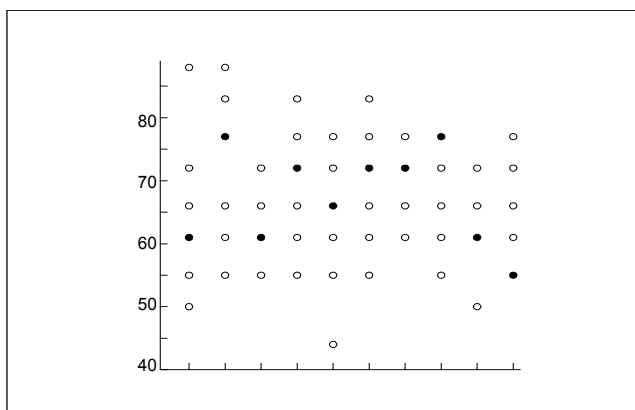

Fig. 11. Degree of match by 18 dimensions for a feature vector.

without any influence to the recognition accuracy. We proposed a new feature extraction process. This method can efficiently represent a feature vector with 87 dimensions and it requires only one bit per dimension. Regardless of the successive transform of an image four times, we can separate an input space according to the degree of matching as shown in Fig. 10. In the Fig. 10, the black points mean success of match and the white points mean failure of match. In the Figs. 10 and 11, x-axis means each person and y-axis means the degree of match. If we run transform of the image five times, however, we can not keep a threshold of recognition even though we might obtain much less size of feature vector as shown in Fig. 11. That is why we choose the 87 dimensions for each feature vector, not 18 dimensions. Table 6 shows the performance evaluation according to the size of a feature vector.

Table 6. Performance evaluation according to the size of feature vectors.

	256 dimension (1 byte/dimension)	87 dimension (1 bit/dimension)
Learning Data	97.8 %	98.0 %
Test Data	97.2 %	97.2 %

For efficient comparison with the proposed scheme for organizing a feature vector, we used 256 dimensions (1 byte per dimension) for each vector introduced in [4]. As the feature vector size is one twentieth compared with the 256 dimensions (1 byte per dimension), the performance in the process of recognition and verification is expected to be improved. All of the experimental results on the proposed methods are summarized in Table 7.

Table 7. Performance evaluation on the proposed methods.

Feature Extraction	Gabor transform	Wavelet transform			
		Initializaiton with random values		Uniform distribution of initial weight	
Recognition	Euclidean distance-based winner selection		Multi-dimensional Winner Selection		
	256 dimension (1 bytes/dimension) 2,048 bits				87 dimension (1bit/dimension) 87 bits
Learning Data	97.8 %	98.0 %	99.2 %	99.6 %	99.8 %
Test Data	92.3 %	94.4 %	97.6 %	98.7 %	99.3 %

3. Overall Performance of Proposed System

The performance of biometric systems is usually described by the two error rates: FAR and FRR. In order to determine a threshold separating FRR and FAR, we compare the feature vector of an unknown pattern with the weight vector obtained from the corresponding output node of LVQ, count the number of matched bits, and then use the ratio of matched bits over 87 bits as the degree of match. For these experiments, we divide data into two groups including each 100 person: one is for LVQ learning and for false reject test (Group 1), and the other for false accept test (Group 2). We use 5 data per person for LVQ learning from Group 1.

A. Experiment for FRR

For this experiment, we use 20 data per person from data of Group 1 that are not exploited in the LVQ learning process. The degree of match between the unknown patterns and the registered (trained) patterns is illustrated in Fig. 12. In the figure, x-axis and y-axis indicate the number of data and the degree of match, respectively.

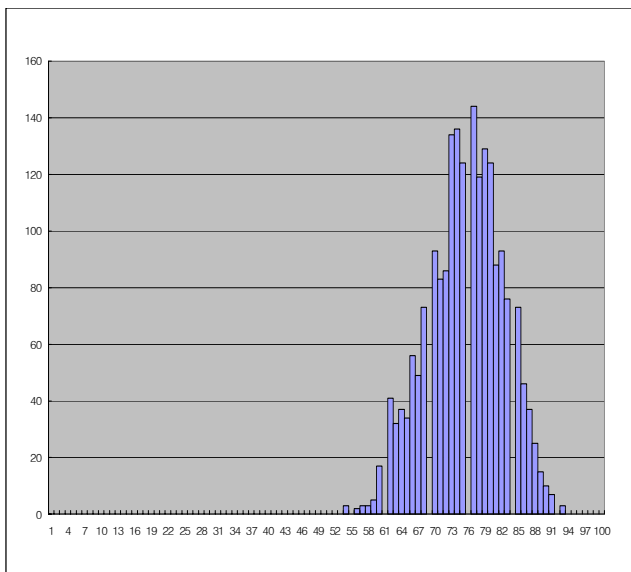

Fig. 12. Degree of match for the same persons (Authentic).

B. Experiment for FAR

For this experiment, we use 20 data per person from Group 2, which can be regarded as the imposters. The degree of match between the unknown patterns for imposters and the registered patterns is illustrated in Fig. 13. In the figure, x-axis and y-axis indicate the number of data and the degree of match, respectively.

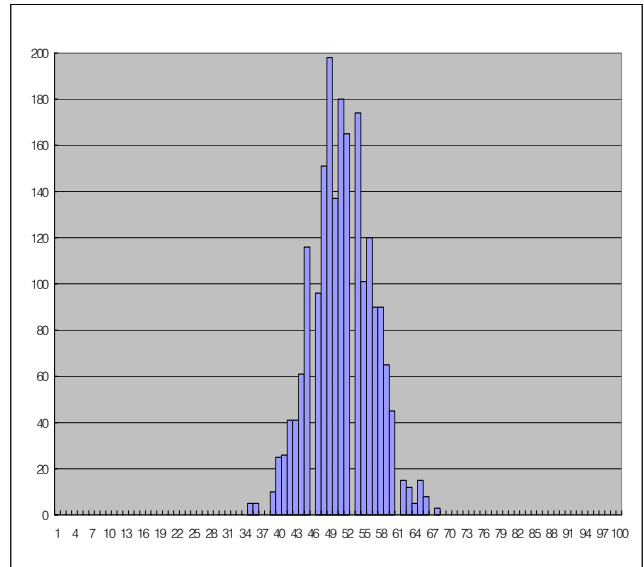

Fig. 13. Degree of match for the different persons (Imposter).

Figure 14 shows the change of two error rates according to the degree of match for selecting a proper point as a threshold. By selecting the intersection point of two error curves as a threshold, we can minimize two error rates simultaneously. When we use the threshold of 60.5 or 61.5, we can get the performance of about 97.1% to 98.4%. Table 8 indicates FAR and FRR according to the degree of match.

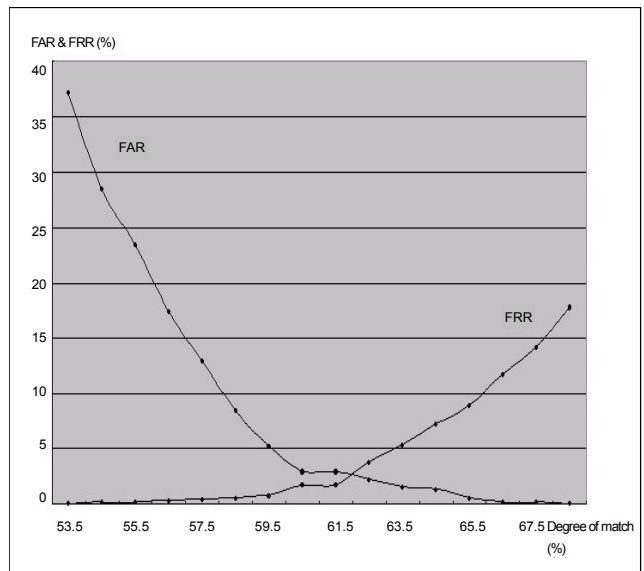

Fig. 14. Change of two error rates according to the degree of match.

Because the experiments on FAR and FRR have been conducted for the data preprocessed successfully, the recognition rate over all of the data including the unsuccessful data in the preprocessing stage is decreased by about 10%. Therefore, a

great deal of efforts should be placed on the improvement of techniques in the preprocessing stage to get higher reliability. The processing time from the data acquisition to the identification/verification takes about 2 seconds.

Table 8. FAR and FRR according to the degree of match.

Degree of Match (%)	FRR (%)	FAR (%)
53.5	0.00	37.15
54.5	0.15	28.45
55.5	0.15	23.40
56.5	0.25	17.40
57.5	0.40	12.90
58.5	0.55	8.40
59.5	0.80	5.15
60.5	1.65	2.90
61.5	1.65	2.90
62.5	3.70	2.15
63.5	5.30	1.55
64.5	7.15	1.30
65.5	8.85	0.55
66.5	11.65	0.15
67.5	14.1	0.15
68.5	17.75	0.00

V. CONCLUSIONS

In this paper, an efficient method for personal identification and verification by means of human iris patterns is presented. To process the iris patterns in an efficient and effective way against existing methods, the following studies are conducted: First, two methods—Gabor transform and Haar wavelet transform which are widely used for extracting features—were evaluated. From this evaluation, we found that Haar wavelet transform has better performance than that of Gabor transform. Second, Haar wavelet transform was used for optimizing the dimension of feature vectors in order to reduce processing time and space. With only 87 bits, we could present an iris pattern without any negative influence on the system performance. Last, we improved the accuracy of a classifier, a competitive learning neural network, by proposing an initialization method of the weight vectors and a new winner selection method designed for iris recognition. With these methods, we could increase the recognition performance to 98.4%. From the experimental results, we are convinced that the proposed system

is optimized enough to be applied to various real applications.

REFERENCES

- [1] Adler F. H., *Physiology of the Eye: Clinical Application*, The C. V. Mosby Company, 1965.
- [2] Hallinan P. W., "Recognizing Human Eyes", *SPIE Proc. Geometric Methods in Computer Vision*, 1570, 1991, pp. 214-226.
- [3] Flom L. and Safir A., "Iris recognition system," U.S. Patent 4 641 349, 1987.
- [4] John G. Daugman, "High Confidence Visual Recognition of Persons by a Test of Statistical Independence", *IEEE Trans. on Pattern Analysis and Machine Intelligence*, 15(11), 1993, pp. 1148-1161.
- [5] Williams, G.O., "Iris Recognition Technology", *IEEE Aerospace and Electronics Systems Magazine*, 12(4), 1997, pp.23-29.
- [6] Wildes, R.P., "Iris Recognition: An Emerging Biometric Technology", *Proc. of the IEEE*, 85(9), 1997, pp.1348-1363.
- [7] Wildes, R.P., Asmuth, J.C. *et al.*, "A System for Automated Iris Recognition", *Proc. of the Second IEEE Workshop on Applications of Computer Vision*, 1994, pp.121-128.
- [8] Boles, W.W. and Boashash, B., "A Human Identification Technique Using Images of the Iris and Wavelet Transform", *IEEE Trans. on Signal Processing*, 46(4), 1998, pp.1185-1188.
- [9] Randy K. Young, *Wavelet Theory and Its Application*, Kluwer Academic Publisher, 1992.
- [10] Rioul O. and Vetterli M., "Wavelet and Signal Processing", *IEEE Signal Processing Magazine*, October 1981, pp. 14-38.
- [11] Gilbert Strang, Truong Nguyen, *Wavelets and Filter Banks*, Wellesley-Cambridge Press, 1996.
- [12] Fausset L., *Fundamentals of Neural Networks*, Prentice Hall, 1994.
- [13] Kohonen T., *The Self-organization and Associate Memory*, Springer-Verlag, 1985.
- [14] Ilgu Yun *et al.*, "Extraction of Passive Device Model Parameters Using Genetic Algorithms", *ETRI J.*, Vol. 22, No.1, 2000, pp.38-46.
- [15] Sang-Mi Lee, Hee-Jung Bae, and Sung-Hwan Jung, "Efficient Content-based Image Retrieval Methods using Color and Texture", *ETRI J.*, Vol.20, No.3, 1998, pp.272-283.
- [16] Young-Sum Kim *et al.*, "Development of Content-based Trademark Retrieval System on the World Wide Web", *ETRI J.*, Vol.21, No.1, 1999, pp.40-53.



Shinyoung Lim received B.E. degree in industrial chemistry from Kon-Kuk University, Seoul, Korea in 1983, and M.S. degrees in chemical engineering and computer science from Kon-Kuk University in 1985 and 1992, respectively, and Ph.D. degree in computer science from Korea University, Seoul in 2001. He joined the Systems Engineering Research Institute(SERI), Korea Institute of Science and Technol-

ogy(KIST) in 1986. Since then, he was a principal member of research staff in the field of software engineering, data communication and computer networks, and information security until 1996. He is currently working in Electronic Commerce Technology of Electronics and Telecommunications Research Institute(ETRI), as a team leader of Electronic Payment Team. His current interests include the area of electronic commerce security, digital contents copyright protection, biometrics, and mobile commerce security. He is a member of the Korean Electronic Payment Forum, KIPS, and KICS.



Kwanyong Lee received the M.S. and the Ph.D. degrees in computer science from Yonsei University, Seoul, Korea in 1991 and 1994, respectively. From 1989 to 1999, he was a researcher in the Research Institute of Natural Science, Yonsei University. From 1997 to 1999, he joined the department of information and communication engineering at the University of Tokyo in Japan as a visiting researcher. In 1999, he

was a senior researcher in the EC/CALS division of the Electronics and Telecommunications Research Institute in Taejon, Korea. Since August 2000, he has been a researcher in the department of computer science of Yonsei University and he is responsible for developing and evaluating various image-processing-based biometric systems. His current research interests include video-based biometrics, pattern recognition, computer vision, and image processing.



Okhwan Byeon received his B.E. degree in communication engineering from National Aviation University, Seoul, Korea in 1979, and M.S. degree in information engineering from Inha University in 1985, and Ph.D. degree in information communication engineering from Kyeonghee University in 1995, respectively. He joined the Data Communication Section, Korea Institute of Science and Technology(KIST) in

1978. Since then, he was a principal member of engineering staff in the field of Data Communication and Computer Networks until 1996. He is currently working in Supercomputing Center of Korean Information of Science & Technology Institute(KISTI), as a head of High Performance Networking Lab. His current interests include the area of distributed computing, internet traffic engineering and security. He is a member of the KIPS, KISS, KICS, and KIISC.



Taiyun Kim received B.S. in industrial engineering science from Korea University, 1981. He received M.S. in computer science from the Wayne State University, 1983. He received Ph.D. in computer science from the Auburn University, 1987. At present, he is a professor at the department of computer science and engineering in the Korea University. His research interests are computer networks, EDI systems, security, biometrics, ISDN, satellite communication, and computer graphics.