

Phase Noise Reduction of Microwave HEMT Oscillators Using a Dielectric Resonator Coupled by a High Impedance Inverter

Moon-Que Lee, Keun-Kwan Ryu, and In-Bok Yom

ABSTRACT—The phase noise reduction in a configuration of the HEMT oscillator with a dielectric resonator coupled by a quarter-wavelength impedance inverter is investigated. Two HEMT oscillators for a satellite payload system are manufactured in the same configuration except for the coupling configuration of the dielectric resonator (DR) in order to empirically demonstrate the phase noise reduction. Experimental result shows that a phase noise reduction by 14 dB can be enhanced by increasing the characteristic impedance of a coupling microstrip impedance inverter.

I. INTRODUCTION

A dielectric resonator oscillator (DRO) is a cost effective solution for achieving a highly stable and low phase noise source in the microwave range. In DRO configurations, a popular design topology is the series feedback shown in Fig. 1(a). In this configuration, the dielectric resonator (DR) is usually coupled by a 50 Ω microstrip terminated by a resistor with the same characteristic impedance as the coupling microstrip in order to avoid the spurious oscillation especially in a low frequency band.

In this letter, we show that a phase noise enhancement can be achieved by increasing the characteristic impedance of the coupling microstrip as shown in Fig. 1(b). To demonstrate the phase noise reduction, two DROs for a satellite payload system are built in different DR coupling structures: one is coupled by

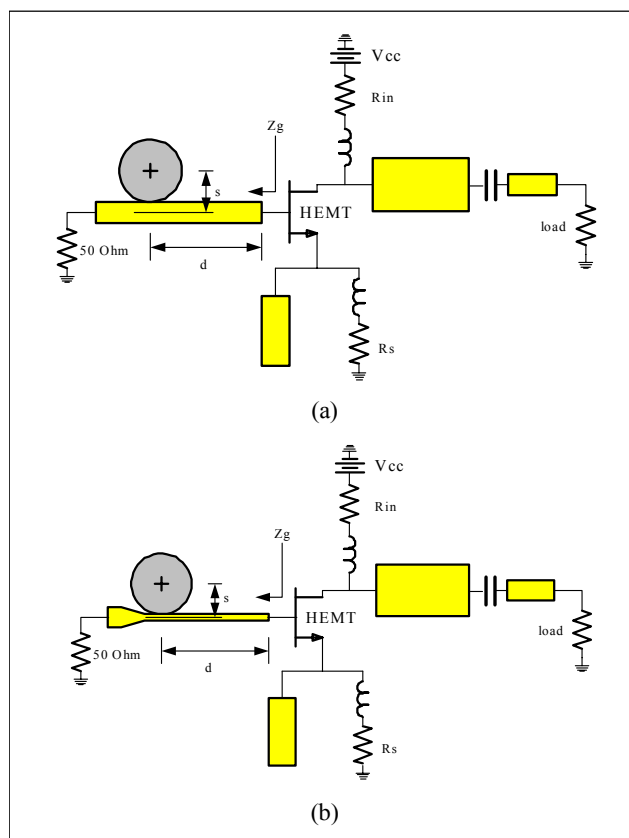

Fig. 1. Series feedback: (a) conventional DRO configuration (Type I) and (b) the proposed DRO with the optimized characteristic impedance of coupling microstrip inverter (Type II).

a 50 Ω micstrip and the other by a higher impedance microstrip. The phase noise reduction is explained in terms of a reso-

Manuscript received August 14, 2001; revised October 4, 2001.
Moon-Que Lee (phone: +82 42 860 5961, e-mail: mqlee@etri.re.kr), Keun-Kwan Ryu (e-mail: kkryu@etri.re.kr), and In-Bok Yom (e-mail: ibyom@etri.re.kr) are with the Communication Satellite Development Center, ETRI, Daejeon, Korea.

nator characteristic graph and an approximated Kurokawa's phase noise model for high Q oscillators.

II. RESONATOR DESIGN

Figure 2 shows the equivalent circuit for a DR coupling structure. The reactance slope of the equivalent circuit for a DR port is proportional to the length of the coupling microstrip, where a quarter wavelength gives the steepest reactance slope. Therefore, low noise oscillators use a microstrip of about a quarter wavelength [1]. The coupling microstrip line operates as an impedance inverter when its electrical length is around 90 degrees. An impedance inverter converts the parallel resonant circuit into the series resonant circuit. Figure 3 shows the simulated impedance curves of a DR for the different microstrip lines (50Ω and 80Ω lines). The reactance slope of the DR coupled by a high characteristic impedance inverter is steeper than that of the DR with a low characteristic impedance inverter.

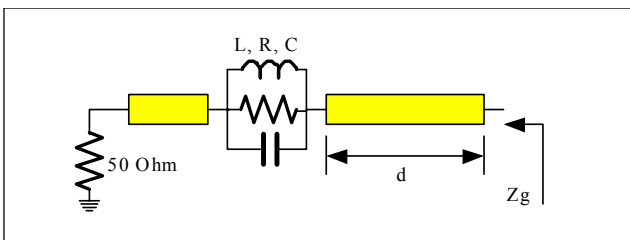

Fig. 2. Equivalent circuit for a DR coupled by a microstrip around a quarter wavelength.

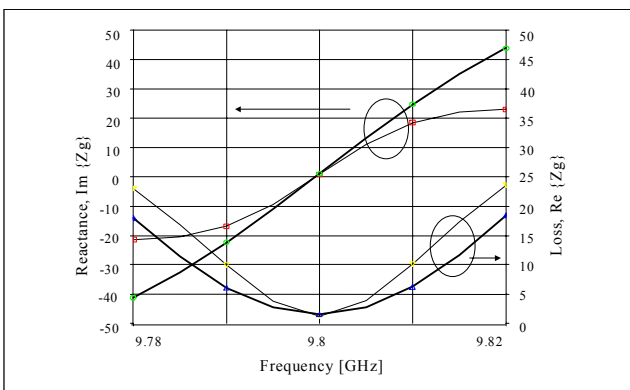

Fig. 3. Simulated impedance curves around the resonant frequency (thin line: 50 Ω microstrip coupling, thick line: 80 Ω microstrip coupling).

Around a quarter wavelength, also, the loss of high impedance inverter coupling shows lower compared with 50 Ω line coupling structure. The high impedance coupling structure has the higher conductor loss in the microstrip than the low impedance one. The microstrip loss, however, has a minor effect on

the total loss around a quarter-wavelength. Therefore, we can deduce that a DRO with a high impedance inverter shows the enhanced phase noise and higher power than a conventional DRO with a 50 Ω impedance inverter.

III. OSCILLATOR DESIGN

A Fujitsu FHX35LG HEMT is used as an active device of the manufactured.

Two types of oscillators for a satellite payload system were designed in series feedback topology as shown in Fig. 1. Transistors are self-biased with resistors connected to the sources of the transistors. The source and drain impedances were first determined with the embedding network synthesis formula for the maximum oscillation power, and then the detuning is performed to enhance the phase noise performance.

The source impedance of $-j50.4\Omega$ is implemented by a microstrip open stub. The drain impedance of $25.7 - j7.8\Omega$ is realized by using a step impedance inverter. The input impedance looking into the transistor with source and drain impedances is $-39 + j7.05\Omega$ at 9.8 GHz.

For the gate impedance, those oscillators have different forms. One (Type I) utilizes a conventional resonator network composed of a DR and a 50 Ω microstrip line. The other (Type II) uses a coupling microstrip inverter with high characteristic impedance. This allows for a comparison of the phase noise performance for oscillators with the different DR coupling networks. The characteristic impedance of the Type II microstrip line is 80 Ω and the line width is 0.35 mm when implemented on a 0.385 mm-thick TMM3™ substrate. The unloaded Q of $TE_{01\delta}$ mode dielectric resonator is 7000 under the recommended cavity from TransTech. Both oscillators are self-biased with $V_{CC} = 8V$, $R_S = 50\Omega$, and $R_m = 50\Omega$. The transistor draws a DC current of about 17mA.

IV. EXPERIMENT RESULTS

The manufactured circuits are tuned to oscillate around 9.8 GHz by slightly adjusting a tuning screw. The position of a DR is fixed approximately at the vicinity of the quarter-wavelength from the gate of the transistor. It is well known that the phase noise and oscillation power are sensitive to the gap between DR and the coupling microstrip, which is empirically determined for an oscillator to show the best phase noise performance.

The phase noise is measured by a spectrum analyzer (Agilent-8563E) with a condition of a 10kHz resolution bandwidth. Type I and Type II oscillators show phase noise

characteristics of -102.2 dBc/Hz and -116.2 dBc/Hz at 100kHz offset frequency, respectively. Figure 4 shows the measured power spectrums of the manufactured oscillators. The comparison of the manufactured oscillators is summarized in Table I. The oscillator with the DR coupled by a high impedance microstrip inverter (Type II) gives a 14-dB improvement in phase noise compared with Type I. The improvement in phase noise can be explained by the Kurokawa's phase noise model.

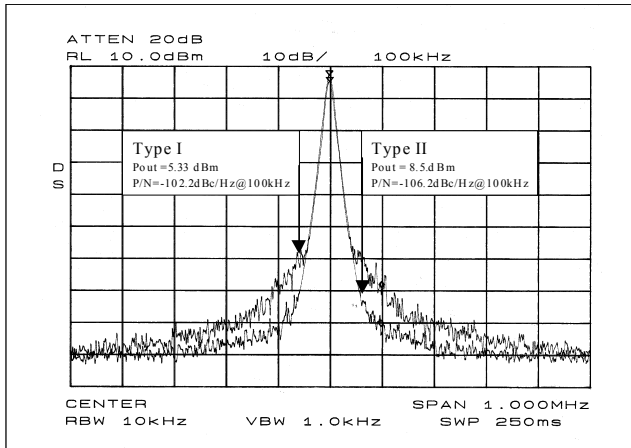

Fig. 4. Comparison of phase noise measurements of Type I and Type II oscillators.

Table I. Comparison of a conventional DRO and the proposed one.

Parameters	A Conventional DRO Type I	The Proposed DRO Type II
Oscillation Frequency	9.788641 GHz	9.781124 GHz
Output Power	5.33 dBm	8.5 dBm
DC current	17 mA	18 mA
Phase Noise @ 100kHz	-102.2 dBc/Hz	-116.2 dBc/Hz

A modification of Kurokawa's phase noise model for the oscillator with a high Q resonator can be written as [2] :

$$|\delta\phi(\omega)|^2 = \frac{2|e|^2}{\omega^2 A_o^2 \left| \frac{\partial X_g}{\partial \omega} \right|^2}, \quad (1)$$

where $|e|$ is the internal noise source and $|A_o|$ is the amplitude of oscillation signal.

From Table I, the measured oscillation amplitude ratio is 1.44, which corresponds to a phase noise enhancement of 3.17 dB from (1). The rest phase noise enhancement is contributed

to the difference of reactance slope and the DR coupling ratio. From Fig. 3, the DR with a high impedance inverter gives steeper reactance slope as well as low loss around the quarter-wavelength.

The reason that the oscillation power of Type II is higher than that of Type I is concerned with DR coupling ratio. The oscillation power increases as the coupling becomes tighter. A 80Ω microstrip has a narrower line width than a 50Ω microstrip, which enables DR to have a tighter coupling with the microstrip.

V. CONCLUSION

Phase noise reduction of microwave HEMT oscillators by increasing the characteristic impedance of the coupling microstrip has been demonstrated. Compared with a HEMT oscillator with DR coupled by a 50Ω microstrip line, the performance of the proposed HEMT oscillator shows a phase noise reduction by 14 dB. Applying this idea to MESFET or HBT oscillators would show a better phase noise performance enhancement because these devices have an extremely low flicker noise [3].

REFERENCES

- [1] H. Ikematsu, M. Inoue, K. Kawakami, T. Katoh, K. Itoh, Y. Isota, and O. Ishida, "A V-band MMIC VCO with a Sub-Resonator Coupled by a 90-Degree Inverter," *Asia-Pacific Microwave Conf.*, vol. 1, 1998, pp.143-146.
- [2] K. Kurokawa, "Some Basic Characteristics of Broad Band Negative Resistance Oscillator Circuit," *Bell Sys. Tech. J.*, vol. 48, no. 6, July 1969, pp.1937-1955.
- [3] B.R. Ryum and S.I. Kim, "The Effect of Dopant Outdiffusion on the Neutral Base Recombination Current in Si/SiGe/Si Heterojunction Bipolar Transistors," *ETRI J.*, vol. 15, no. 3/4, Jan. 1994, pp.61-69.