

A Supervisor-Based Neural-Adaptive Shift Controller for Automatic Transmissions Considering Throttle Opening and Driving Load

Byung-Kwan Shin*, Jin-Oh Hahn

Department of Mechanical Design and Production Engineering, Seoul National University

Kyongsu Yi

Division of Mechanical Engineering, Hanyang University

Kyo-II Lee

Department of Mechanical and Aerospace Engineering, Seoul National University

Recently, many passenger cars have adopted automatic transmissions for shifting gears, and thus the smooth and precise control of gear shifts of passenger car automatic transmissions has become more and more essential for the riding comfort of vehicles equipped with automatic transmissions. In this article, a neural network-based supervisor for an automotive shift controller considering the throttle opening, variations in throttle opening, and the driving load is presented. For using the driving load information, an observer-based driving load estimation algorithm is proposed. A proportional-integral-derivative controller along with an open loop controller is used as a low level controller for controlling the gear shifts, and a supervisory controller for properly adapting the shift control parameters of the low level shift controller is designed using ANFIS. To evaluate the control performance of the proposed supervisor-based shift controller, both simulation studies and experimental studies are performed for various shifting situations.

Key Words : Adaptive Shift Controller, State Observer, Driving Load, Supervisory Controller, ANFIS

1. Introduction

Nowadays, the use of automatic transmissions as a tool for shifting gears in passenger cars is increasing, and in accordance with this trend, studies on the shift control of automatic transmissions have been extensively carried out to reduce the shock in shifting gears and to improve shift characteristics. Lim et al. (1998) used a PID controller and an engine spark retard controller to reduce the shift transient shock. Also, Jung et

al. (1998) proposed a shift controller that consists of a PID controller and an open loop controller, and Hur et al. (1998) adopted this control algorithm to a newly developed hydraulic clutch control system (CDDC) to improve the shift quality of automatic transmissions.

However, to guarantee good shift quality over various gear shifting situations, the control parameters of a shift controller should be appropriately adapted to the driving conditions. In this article, a PID controller along with an open loop controller that was suggested by Jung et al. (1998) is used as a low level shift controller. And a supervisory controller to consider the effect of various driving conditions, represented by the throttle opening of an engine and the driving load, is designed using ANFIS (Jang, 1993) to

* Corresponding Author,

E-mail : sbk4all@snu.ac.kr

TEL : +82-2-880-7143 ; FAX : +82-2-883-1513

Department of Mechanical Design and Production Engineering, Seoul National University (Manuscript

Received August 27, 1999; Revised December 21, 1999)

obtain improved shift quality by properly adapting the control parameters of the low level shift controller. To prove the performance of the suggested control algorithm, both simulations and experiments are carried out for various shifting situations.

2. Dynamic Models of System

The system considered in this study is shown in Fig. 1, and is composed of an engine, a torque converter, a power transmission system, a driveline, and a hydraulic control system which acts as an actuator for the shift control. The engine is the power source of the entire system, and the torque converter transmits the power generated by the engine to the power transmission system. The dynamic models of the engine and torque converter are as follows:

$$I_e \dot{\omega}_e = T_e - T_p \tag{1}$$

$$T_p = C_p \omega_e^2 \tag{2}$$

$$T_t = T_r T_p \tag{3}$$

where I , ω , T represent the rotational inertia, angular velocity, and torque, respectively, and the subscripts e , p , t denote engine, impeller, and turbine, respectively.

The power transmission system is operated by the action of the hydraulic control system. Shifting gears occurs in this component, and it also transmits power to the driveline and wheels. When a vehicle is in operation, the driving load consisting of grade resistance, aerodynamic drag force, and friction force between the tire and the road acts on the vehicle as a resistive force. Shin et al. (1998) established the mathematical model of the power transmission system considered in

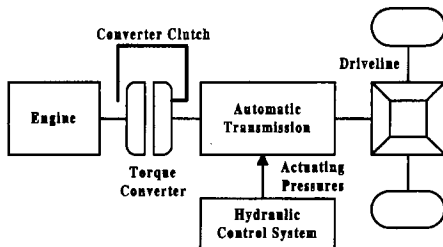

Fig. 1 Schematic of the powertrain system

this study; only the dynamic model of the driveline is presented in this article. The dynamic model of the driveline is described in Eqs. (4) ~ (5):

$$I_v \dot{\omega}_w = R_d T_b - T_l \tag{4}$$

$$\dot{T}_b = K_s (R_{t,i} \omega_t - R_d \omega_w) \tag{5}$$

where R_d and $R_{t,i}$ denote the final differential gear ratio and the transmission gear ratio at the i -th shift position, respectively. The subscripts v and w respectively denote the vehicle and wheel, and K_s , T_b , and T_l are the stiffness constant of the wheel axle, the transmission output torque, and the driving load torque, respectively. The dynamic models described here are used in the subsequent simulation studies.

In general, the driving load in Eq. (4) is expressed as Eq. (6), and the factors affecting the value of the driving load are the vehicle speed and the grade:

$$\begin{aligned} T_l &= r_t (F_a + F_g + F_f) \\ &= r_t (C_a V^2 + m_v g \sin \theta + \mu_f m_v g) \end{aligned} \tag{6}$$

where r_t is the radius of the tire, and F_a , F_g and F_f denote aerodynamic drag force, grade resistance and friction force; V and θ are the longitudinal velocity of a vehicle and the grade of the road, respectively, and C_a , m_v , g and μ_f are

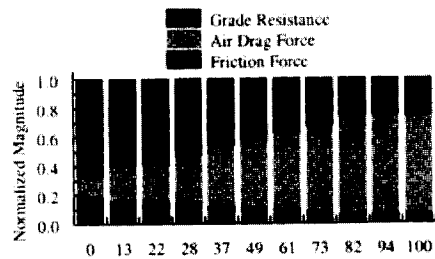

(a) Grade=2Degrees

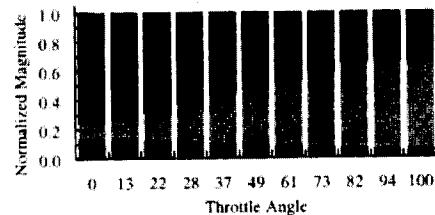

(b) Grade=3Degrees

Fig. 2 Relative magnitudes of resistive forces

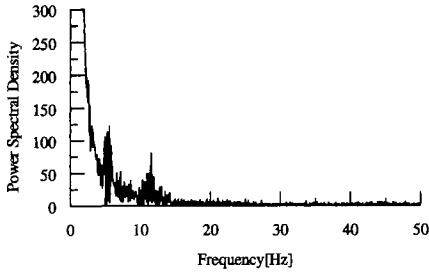

Fig. 3 Frequency characteristics of signals

constants.

To analyze the relative effect of each resistive force comprising the driving load, the relative magnitudes of the forces at 2 → 3 shift points are compared and shown in Fig. 2. As is evident from Fig. 2, the grade resistance occupies a large portion of the driving load and should be taken into account when controlling the shift.

3. Characteristics of Measurement Signal

To design the low pass filter for the measured speed signals, the frequency characteristics of the signal must be known in advance. Based on experimental data from several sources, the power spectral densities of the speed signal are plotted; Fig. 3 shows a typical result. It can be seen from Fig. 3 that the measurement noise of frequencies higher than 30Hz can be ignored. The result of this FFT analysis is used to design low pass filters for the linear driving load observer.

4. Driving Load Estimator Design

As shown in Fig. 2, the grade resistance is one of the most dominant factors of vehicular driving load, and it is necessary to consider its effect when controlling the gear shifting process. Generally, there are two alternatives to obtaining the signal of interest: to measure the signal with a sensor, or to estimate the signal by some proper estimation method. To install an additional sensor, however, may result in increased cost. Instead we propose an estimation method for vehicular driving load (Hahn, 1999) using a linear state observer.

To design an observer-based driving load estimator, the following dynamic model of the

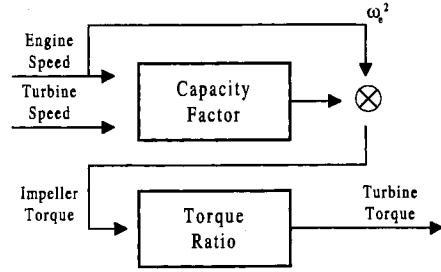

Fig. 4 Turbine torque estimation method

automotive driveline is considered:

$$\begin{aligned} \dot{\omega}_t &= I_t^{-1}(T_t - R_{t,i}T_b) \\ \dot{\omega}_w &= I_v^{-1}(R_d T_b - T_t) \\ \dot{T}_b &= K_s(R_{t,i}\omega_t - R_d\omega_w) \end{aligned} \tag{7}$$

Assuming that the outputs of the driveline system are angular velocities of the turbine and the wheel, and the inputs to the system are the turbine torque and driving load, Eq. (7) can be rewritten in the following linear form:

$$\begin{aligned} \dot{x} &= \begin{bmatrix} \dot{\omega}_t \\ \dot{\omega}_w \\ \dot{T}_b \end{bmatrix} \\ &= \begin{bmatrix} 0 & 0 & -I_t^{-1}R_{t,i} \\ 0 & 0 & I_v^{-1}R_d \\ K_sR_{t,i} & -K_sR_d & 0 \end{bmatrix} \begin{bmatrix} \omega_t \\ \omega_w \\ T_b \end{bmatrix} \\ &+ \begin{bmatrix} I_t^{-1} & 0 \\ 0 & -I_v^{-1} \\ 0 & 0 \end{bmatrix} \begin{bmatrix} T_t \\ T_i \end{bmatrix} = Ax + Bu \tag{8} \\ y &= \begin{bmatrix} 1 & 0 & 0 \\ 0 & 1 & 0 \end{bmatrix} \begin{bmatrix} \omega_t \\ \omega_w \\ T_b \end{bmatrix} + \begin{bmatrix} n_t \\ n_w \end{bmatrix} = Cx + n \end{aligned}$$

where n denotes the measurement noise vector.

The conventional linear state observer for the driveline model in Eq. (8) is designed as

$$\dot{\hat{x}} = A\hat{x} + B\hat{u} + L(y - C\hat{x}) \tag{9}$$

where \hat{x} and \hat{u} are the estimated values of the state vector and the input vector, respectively, and L is the observer gain matrix to be designed. Because in this case the inputs to the system are assumed to be torque signals which cannot be measured, the inputs must be estimated simultaneously with the states. The turbine torque can be estimated using steady-state characteristics of the torque converter as shown in Fig. 4, and its

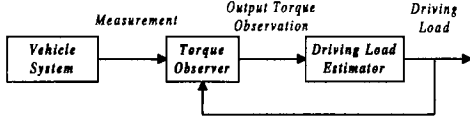

Fig. 5 Driving load estimation algorithm

equation is described in Eqs. (2) ~ (3). The driving load torque can be estimated using the estimated output torque of the power transmission system and the wheel acceleration as shown in Eq. (10).

$$\hat{T}_l = -I_v \dot{\omega}_w + R_d \hat{T}_b \quad (10)$$

The scheme of the suggested driving load estimation algorithm is briefly illustrated in Fig. 5.

The error dynamics of the state observer is given by Eq. (11), and the gain matrix L can be determined so that the poles of the matrix $F-LC$ are located in the left-half s -plane. According to Fig. 3, the result of the measurement signal analysis, a low pass filter having 25Hz cut-off frequency is used to suppress the effect of the measurement noise on the signals used by the driving load estimator.

$$\begin{aligned} \dot{e} &= \dot{x} - \dot{\hat{x}} \\ &= (A-LC)e + B \begin{bmatrix} T_t - \hat{T}_t \\ T_t - \hat{T}_t \end{bmatrix} - Ln \\ &= \left\{ \begin{bmatrix} 0 & 0 & -I_t^{-1}R_{t,i} \\ 0 & 0 & 0 \\ K_s R_{t,i} & -K_s R_d & 0 \end{bmatrix} - LC \right\} e \\ &+ \begin{bmatrix} I_t^{-1} \\ 0 \\ 0 \end{bmatrix} (T_t - \hat{T}_t) - Ln = (F-LC)e \\ &+ \begin{bmatrix} I_t^{-1} \\ 0 \\ 0 \end{bmatrix} (T_t - \hat{T}_t) - Ln \end{aligned} \quad (11)$$

5. Shift Controller Design

The scheme of the automotive shift controller proposed in this article is described in Fig. 6. It consists of a shifting point controller, a low level shift controller, and a supervisory controller for properly adjusting the parameters of the low level shift controller with respect to the throttle angle and the driving load information. The shifting

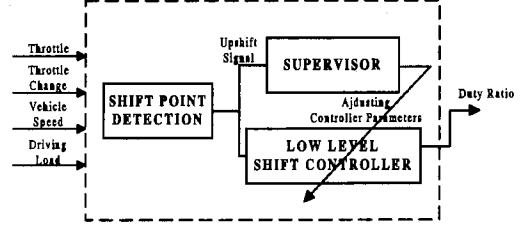

Fig. 6 Shift controller architecture

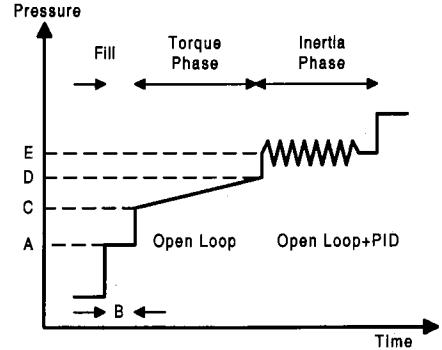

Fig. 7 Low level shift control algorithm

point controller, which is not mentioned in this article, determines the shifting points. The low level shift controller consists of an open loop controller and a PID controller. The supervisor adapts the parameters of the low level shift controller based on the throttle angle and the driving load information.

5.1 Low level controller

Figure 7 briefly illustrates the clutch pressure trajectory when shifting gears. When shifting starts, a high duty ratio is supplied to the clutch to fill the clutch chamber. After the fill phase comes the torque phase, where the pressure is reduced to a certain value and then gradually raised until the turbine angular velocity begins to decrease. The inertia phase starts at this point. During the inertia phase, the turbine speed is controlled to follow a predetermined reference trajectory by some constant feedforward duty ratio plus a PID controller described in Eq. (13):

$$u = u_f + K_p \tilde{\omega}_t + K_i \int \tilde{\omega}_t dt + K_d \frac{d\tilde{\omega}_t}{dt} \quad (13)$$

Here u_f denotes the feedforward duty ratio, K_p , K_i , K_d are gains of the PID controller and $\tilde{\omega}_t$

denotes the tracking error of the turbine speed.

As is obvious from Fig. 7, the adjustable parameters of the low level shift controller are the fill phase duty ratio (A), the fill time (B), the duty ratio for the start of the torque phase (C), the duty ratio for the end of the torque phase (D), and the feedforward duty ratio for the inertia phase (E).

5.2 Supervisory controller

To achieve good shift quality for various driving situations, it is necessary that the parameters for the low level shift controller be adjusted according to the shifting condition. Current shift control algorithms are composed of case-by case control actions, i. e. TCU contains the open-loop control inputs for several driving conditions based on the throttle opening, but actually it is impossible to store the open-loop control inputs for numerous shift situations. In this article, the concept of supervisor is introduced to overcome this limitation and to obtain enhanced shift quality by appropriately adapting the parameters of the low level shift controller.

There have been some trials to employ the supervisor to adjust the shift points, but its applications to shift quality control problems considered in this study are very rare. In this article, three variables – throttle angle, time derivative of the throttle angle, and driving load – are assumed to mainly affect the shift quality. The proper values of the low level shift controller parameters have been extracted, and the nonlinear relationship between the above three variables and the desired parameters of the low level shift controller corresponding to the specific values of the three variables is modeled using ANFIS (Jang, 1993), which is a fuzzy inference system based on the framework of a neural network. The structure of the supervisor is shown in Fig. 8.

Using ANFIS the models for nonlinear systems can be effectively established with this fuzzy system. It consists of 5 layers as shown in Fig. 8. The first layer performs a fuzzification operation for the input variables, while the firing strengths are calculated in the second layer. The firing strengths are normalized in the third layer, and

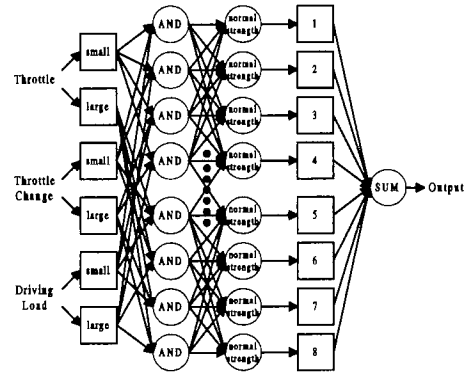
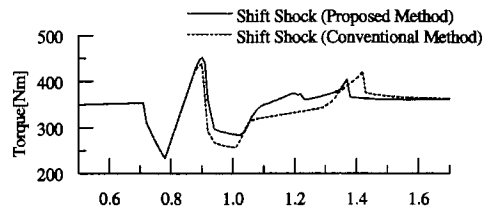
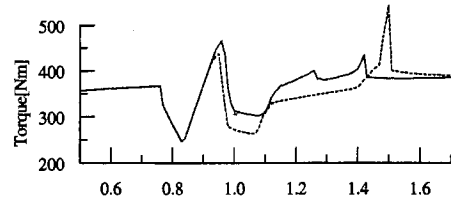

Fig. 8 Structure of the supervisor



(a) Case I



(b) Case II

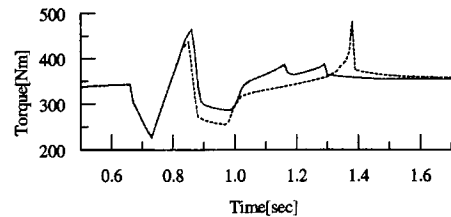

(c) Case III

Fig. 9 Simulation results

the fourth layer performs the fuzzy inference operation. Finally, the defuzzification operation is carried out and the overall output of the fuzzy inference is provided in the fifth layer.

The supervisor considered in this article has 26 tuning parameters, and this neural network has been trained based on the simulation results and the experiment results, respectively. The supervisory controller for adjusting the parameters of the

low level shift controller can be constructed as described in Fig. 8 for each of the parameters (A), (B), (C), (D) and (E) to effectively reduce shift shocks and improve shift qualities under various driving situations.

6. Simulation and Experiment

To prove the performance of the proposed driving load estimator based on the state observer and the supervisor-based shift controller, simulations and experiments are carried out for various shifting situations. In contrast with the proposed method, a conventional method uses a PID control algorithm as a low-level controller and tunes the parameter of the controller with a throttle angle only for various driving conditions.

6.1 Shift control simulation

Figure 10 shows the 2 → 3 shift control simulation results for several shifting situations. To certify the necessity of the supervisory controller for the shift control, only the feedforward duty ratio for the inertia phase is considered to be a parameter that must be adapted in simulation studies. It can be seen from the simulation results that the peak-to-peak values of the shift shocks in the inertia phase are reduced when a supervisor is used in the shift control. It can be concluded that

Table 1 Comparison of inertia phase shift shocks (peak-to-peak value)

| | Conventional | Proposed | Reduction |
|----------|--------------|----------|-----------|
| Case I | 180.97 | 168.58 | 6.84% |
| Case II | 173.13 | 164.37 | 5.05% |
| Case III | 181.78 | 179.2 | 1.42% |

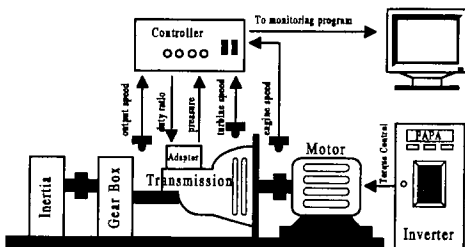

Fig. 10 Experimental apparatus

improved shift quality can be achieved by adapting some controller parameters to various shifting situations. Since only one parameter, that is, the constant feedforward duty ratio for the inertia phase, is considered to be an adaptable parameter by the supervisor, the reduction of shift shocks during the inertia phase are compared. The absolute values of the reduction in the inertia phase shift shocks are described in Table 1.

6.2 Shift control experiment

Figure 11 shows the experimental test setup. An AC motor is used instead of an engine to drive the automatic transmission, and it is controlled by the inverter, which has the percentage of maximum value (motor torque) as an input. The range of the driving condition is limited because the output torque of the AC motor is less than that of the engine. However, the effect of the motor during the shifting state is similar to that of the engine because the inverter controls the motor so that its output torque is constant.

An inertia mass is installed at the transmission output shaft as a vehicle inertia. Additional pay-

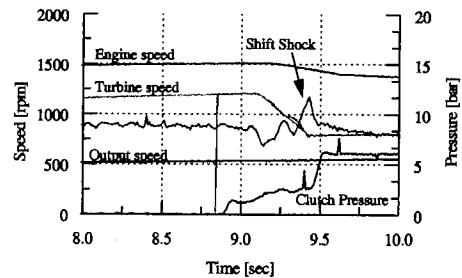

(a) Conventional method

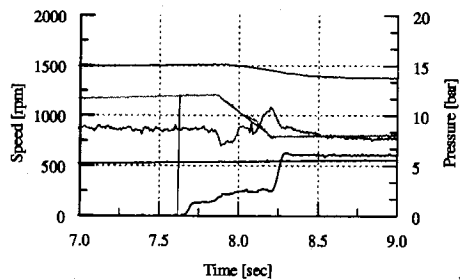

(b) Proposed method

Fig. 11 Experiment result (Motor torque 80%, Payload 55kg)

load can be added to the inertia mass to represent vehicular driving load. The driving load is assumed to be known in the experiments to verify the performance of the supervisor-based shift control method suggested in this article. C, D and E in Fig. 7 are considered as adjustable parameters by the supervisor.

Experiments are performed for various values of the motor torque and the payload which are equivalent to the throttle angles of an engine and the vehicular driving load. Due to hardware limitations, the effect of the change of the motor torque has not been considered in the experimental studies. However, it is insignificant since its effect on the performance of the controller is not dominant (Hahn et al., 1998). Several results are shown in Figs. 12~14.

As is evident from Fig. 12~Fig. 14 and Table 2, through the appropriate adjustment of parameters of the low level controller by the high level controller for various driving conditions, the proposed method can reduce the output shaft torque of the automatic transmission much more

than the conventional method. Therefore, it can be seen that the proposed method for controlling the shift is an effective way to achieve improved shift quality against various shifting situations without tuning the parameter of the controller, which is the case in conventional methods.

The absolute values of the shift shocks during the gear shift for some experimental results are shown in Table 2. It can also be seen that the amount of the reduction of shift shocks can be larger as the parameters adjusted are increased.

Table 2 Comparison of overall shift shocks (Peak-to-peak value)

| Motor/Load | Conventional | Proposed | Reduction |
|------------|--------------|----------|-----------|
| 80/55 | 51.31 | 38.39 | 25.18% |
| 90/55 | 54.63 | 45.77 | 16.21% |
| 90/50 | 60.54 | 50.2 | 17.08% |
| 70/50 | 50.2 | 38.4 | 23.51% |
| 90/60 | 55.74 | 49.83 | 10.60% |

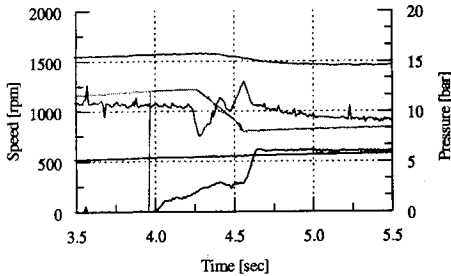

(a) Conventional method

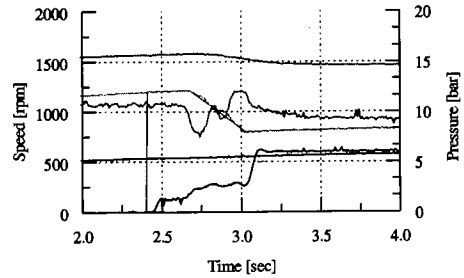

(b) Proposed method

Fig. 12 Experiment result (Motor torque 90%, Payload 55kg)

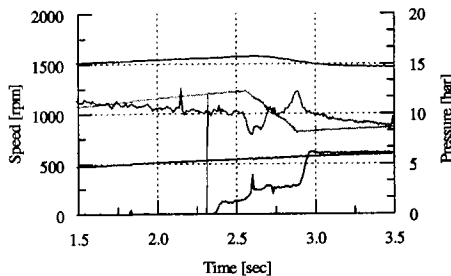

(a) Conventional method

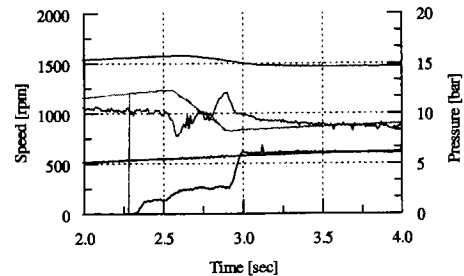

(b) Proposed method

Fig. 13 Experiment result (Motor torque 90%, Payload 50kg)

7. Conclusions

In this article, a new shift control method for vehicular automatic transmissions that achieves good shift quality against various gear shifting situations is suggested. To use the road torque information for shift control, a driving load estimation algorithm based upon a state observer is proposed. A low level shift controller consisting of an open loop controller and a PID controller is designed, and a supervisory controller for properly adjusting the parameters of the low level shift controller in accordance with the external shifting conditions interpreted from input signals such as throttle angle, time derivative of the throttle angle and the driving load is constructed using ANFIS. Through simulations and experiments for various shifting situations, the validity of the proposed shift control method is verified.

In this study, shift control experiments with estimated road slopes were not performed because the experimental apparatus is not a real vehicle. The verification of the performance of the proposed controller with estimated road slopes should be carried out for a complete validation of the control algorithm proposed in this article.

Acknowledgement

This study was supported by the academic research fund of the Ministry of Education, Republic of Korea (ME97-D-11).

References

- Hahn, J. O., Shin, B. K., Yi, K. S., and Lee, K. I., 1999, "Design of an Adaptive Shift Controller Considering Driving Condition and Driving Resistance," *Proc. KSME Fall Annual Meeting*, Vol. A, pp. 687~693.
- Hur, J. W., Han, S. S., and Lee, K. I., 1998, "Development and Analysis of Hydraulic System in Automatic Transmission Using Directly Driven Clutch System," *Proc. 13th KACC*, Vol. 2, pp. 1441~1444.
- Jang, 1993, "ANFIS: Adaptive-Network-Based Fuzzy Inference System," *IEEE Trans. Systems, Man, and Cybernetics*, Vol. 23, No. 3, pp. 665~685.
- Jung, G. H., Cho, B. H., and Lee, K. I., 1998, "Closed-Loop Shifting Control Method During Inertia Phase for INVECS-II Automatic Transmission with Proportional Control Solenoid Valve," *Proc. KSAE Spring Conference*, Vol. II, pp. 872~878.
- Lim, S. H., Hahn, J. O., and Lee, K. I., 1998, "The Dynamic Modeling for Components of Automatic Transmission and Integrated Simulation through the Modular Approach Method," *Transactions of the KSME*, Vol. A 22, No. 12, pp. 2171~2186.
- Shin, B. K., Jung, G. H., and Lee, K. I., 1998, "The Modeling and Analysis of the Powertrain in an Automatic Transmission for Passenger Cars," *Proc. KSME Fall Annual Meeting*, Vol. A, pp. 730~737.