

Development of an Inversion Analysis Technique for Downhole Testing and Continuous Seismic CPT

Joh, Sung - Ho*¹

Mok, Young - Jin*²

요 지

지반의 S파 및 P파의 깊이에 따른 변화를 원위치에서 측정하기 위하여 다운홀 시험(downhole testing)과 SCPT (seismic CPT) 등이 널리 사용되어 왔다. 다운홀 시험과 SCPT는 경제성, 운용의 용이성, 발전원의 단순성 등의 측면에서 효율적이기 때문에, 현재 지반조사에서 그 사용빈도가 더욱 증가하고 있는 추세이다. 특히 최근에는 다운홀과 SCPT의 자료 분석을 자동화하기 위한 노력의 일환으로 interval measurements의 기법이 활용되고 있는데, 현재 이에 대한 적절한 역산해석(inversion analysis) 기법이 없는 형편이다. 따라서, 본 논문에서는 다운홀이나 SCPT의 interval measurements를 분석하기 위한 새로운 역산해석 기법을 제안하였다. 제안된 역산해석 기법의 정모델링(forward modeling)에서는 탄성파의 전파를 Snell의 법칙에 의거하여 굴절·반사되는 현상을 고려하였고, 역산해석을 위해서는 최대공산법(maximum likelihood method)을 적용하였다. 그리고, 본 논문에서 제안한 역산해석 기법의 검증 위하여, 하나의 S파 주상도를 가정하고 이에 대하여 다운홀 시험을 모사하였다. 이론적으로 수행한 다운홀 시험 결과에 대하여 기존의 비역산해석 방법과 본 논문에서 제안한 역산해석 기법에 의해서 S파 주상도를 추정하였는데, 그 결과 본 논문에서 제시한 역산기법이 가장 정확한 결과를 도출하였으며, 다운홀 시험과 SCPT를 자동화하는데 효율적으로 적용이 될 수 있음을 입증하였다.

ABSTRACT

Downhole testing and seismic CPT (SCPT) have been widely used to evaluate stiffness profiles of the subgrade. Advantages of downhole testing and SCPT such as low cost, easy operation and a simple seismic source have got these testings more frequently adopted in site investigation. For the automated analysis of downhole testing and SCPT, the concept of

*1 Member, Assistant Professor, Chung-Ang University

*2 Member, Associate Professor, Kyung Hee University

interval measurements has been practiced. In this paper, a new inversion procedure to deal with the interval measurements for the automated downhole testing and SCPT (including a newly-developed continuous SCPT) is proposed. The forward modeling in the new inversion procedure incorporates ray path theory based on Snell's law. The formulation for the inversion analysis is derived from the maximum likelihood approach, which estimates the maximum likelihood of obtaining a particular travel time from a source to a receiver. Verification of the new inversion procedure was performed with numerical simulations of SCPT using synthesized profiles. The results of the inversion analyses performed for the synthetic data show that the new inversion analysis is a valid procedure which enhances V_s profiles determined by downhole testing and SCPT.

Keywords : Downhole testing, Seismic CPT, Shear wave velocity profile, Inversion, Site investigation, Seismic measurements

1. Introduction

Dynamic soil properties including shear modulus and damping are essential to the investigation of the ground vibration. Specially the analysis for the site response due to the earthquake and construction vibration requires the determination of shear wave velocity (V_s) and damping factors in situ. Among several seismic methods to evaluate dynamic soil properties, downhole testing and seismic CPT (SCPT) are widely adopted in the industry due to its low costs, easy operation, and a simple seismic source.

Downhole testing basically measures the time for body waves to travel from a source on the surface to one or more receivers at different depths in a single borehole. SCPT is a variation of downhole testing, which was originally developed by Campanella et al. (1986). The unique point in SCPT is that no boreholes have to be drilled. The detection of body waves arrived at depths is done by the small transducers incorporated into a cone penetrometer. The seismic portion of the test is performed at discrete points (1-m intervals) when cone penetration testing is stopped and new 1-m long rods are added. Typically, direct or interval S-wave velocity measurements are performed, and straight ray paths are assumed in analyzing the travel time results.

An improved version of SCPT has been developed by engineers at ISMES working with K. Stokoe. This improvement is the continuous measurement of V_s while the cone is being pushed. In this approach, CPT is fitted with two receivers, and a continuous vibratory source is used at the ground surface. Shear waves are constantly generated by the vibratory source which horizontally excites the ground. The shear waves are captured by two receivers, and phase differences between the arrivals of waves at the two receivers are recorded. Continuous measurement of the phase difference is used to determine a continuous V_s profile. Since the phase difference is determined, not travel times, less time is required in evaluating the V_s profile than in conventional measurements. Also, since the measurements are continuous, the V_s profile contains more detail and thinner layers can be resolved.

In this paper, a new inversion technique to evaluate V_s profiles from the phase difference measurements of continuous SCPT, which can be also used to deal with interval measurements of downhole testing, was developed. The forward modeling scheme incorporated in this paper is based on the one developed by Mok (1987), and is additionally able to consider refracted waves. The inversion scheme to evaluate V_s profiles is based on maximum likelihood approach, which is the same one used in SASW inversion analysis (Joh, 1997). Details on the forward modeling scheme and the inversion technique developed in this paper are presented later in this paper.

The accuracy of new inversion procedure was verified. The verification was performed with numerical simulations of SCPT using synthesized profiles. Finally, the comparison between the proposed inversion procedure and conventional analyses was made with the synthesized profiles and also with SCPT measurements performed at a field site in Pontida, Italy.

2. Interpretation of Downhole Testing and SCPT

2.1 Direct Measurements

The method of direct measurements is basically used to interpret conventional downhole measurements in that it requires only one travel time from a source to a receiver. If individual travel times for an upper receiver and a lower receiver of a seismic cone can be measured in SCPT, this method can be used to interpret SCPT. That is, travel time measurements for an upper receiver and a lower receiver are considered as independent downhole measurements.

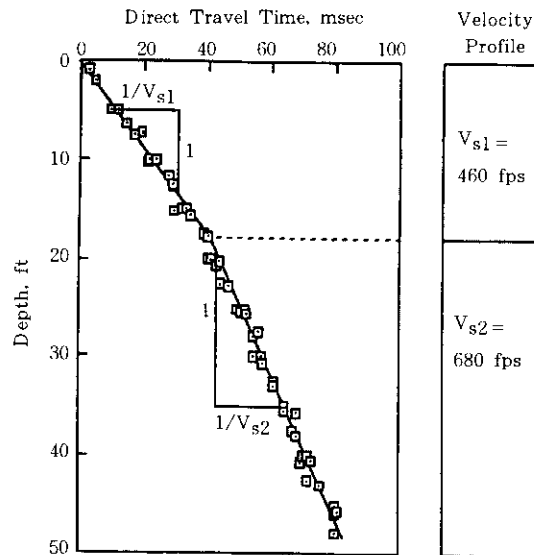

Fig.1 Shear wave velocity profile from direct measurements at site near Parkfield, California(Mok, 1987)

In this method, the velocity profile of a site is obtained by plotting the direct travel times versus depth and then drawing a straight line or a series of straight lines that best-fit the data points as shown in Fig. 1. The inverse of the slope of the line represents the shear wave velocity, and the number of straight lines recognized in the profile expresses the number of the identified subsurface layers. In this manner, a shear wave velocity profile is determined.

2.2 Interval Measurements

Interval measurements indicate that interval travel time, which is defined as the travel-time difference for the upper receiver and the lower receiver of a seismic cone, is used to interpret conventional downhole measurements or SCPT. Figure 2 illustrates the interval measurements. The basic assumption of the interval measurements is that the average velocity of materials on the ray path SU and SL is the same, where SU has the same length as SU'. That is, the travel time for path SU is assumed to be the same as the travel time for path SU'. Therefore, the interval measurement evaluates the velocity of the material on the ray path U'L. When the average velocity for the material on the ray path SU and SU' is V_{avg} and the length of the path is L_1 , the travel time for the wave to reach from point S to point U or U' is expressed as

$$T_1 = \frac{L_1}{V_{avg}} \quad (1)$$

T_2 , which is the travel time for the wave to reach from point S to point L, is defined as

$$T_2 = \frac{L_1}{V_{avg}} + \frac{L_2 - L_1}{V} = T_1 + \frac{L_2 - L_1}{V} \quad (2)$$

where V is the interval velocity. L_1 , L_2 are the travel paths to the upper and lower receiver, respectively, assumed to be straight, and T_1 , T_2 are the travel times to the upper and lower receiver, respectively. Therefore, the velocity for the material on the ray path U'L is calculated as

$$V = \frac{L_2 - L_1}{T_2 - T_1} \quad (3)$$

The interval measurements can be also employed to interpret the continuous SCPT data, which are the phase differences between a upper receiver and a lower receiver. For an excitation frequency, f , phase differences, $\Delta\phi$, can be converted into travel-time difference, Δt , by the following equation.

$$T_2 - T_1 = \Delta t = \frac{\Delta\phi}{2\pi f} \quad (4)$$

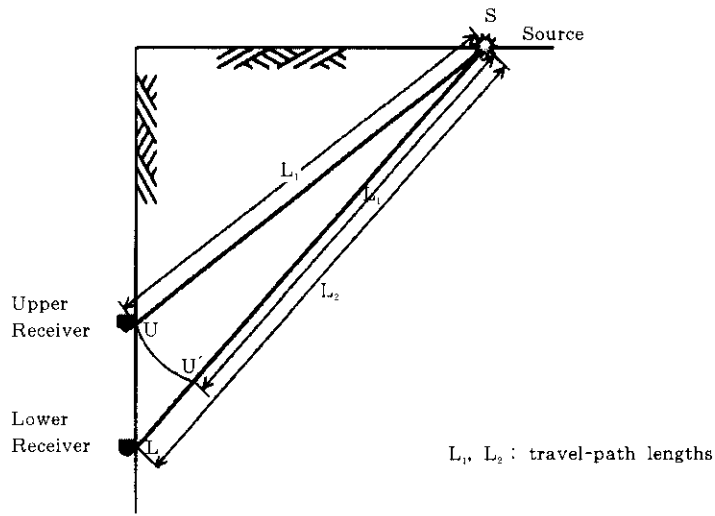

Fig.2 Illustration of interval measurements

2.3 Modified Interval Measurements

Modified interval measurements (Batsila, 1995) is basically the same approach as the interval measurements. Both methods assume straight ray path, which implicates that the wave propagates straightly through a layer. Also, both methods use the difference between the initial arrival time at a upper receiver and the initial arrival time at a lower receiver in evaluating shear wave velocities of layers. However, the modified interval measurements assume that the site is composed of several layers with different shear wave velocities, and consider individual shear wave velocities of all the layers in the interpretation of wave propagation.

In Fig. 3, the schematic description of modified interval measurements is illustrated and the assumption of layering is shown together. In the modified interval measurements, the top of each layer in the layered system is at the same depth as the depth of a upper receiver.

In Fig. 4, the model used to analyze SCPT using the technique of the modified interval measurements is illustrated. The basic assumptions made in the formulation of the model in Fig. 4 are as follows:

- fThe subsurface is modeled as a stack of homogeneous horizontal layers.
- fThe borehole is vertical,
- fThe ray paths are assumed to be straight,
- fThe receiver spacing remains constant,
- fMeasurements are made at depth intervals smaller or equal to the receiver spacing,
- fThe first layer extends from the surface down to the depth of the lower receiver during the first reading, and
- fDepths of all other layers are equal to the additional depths being probed with new measurements.

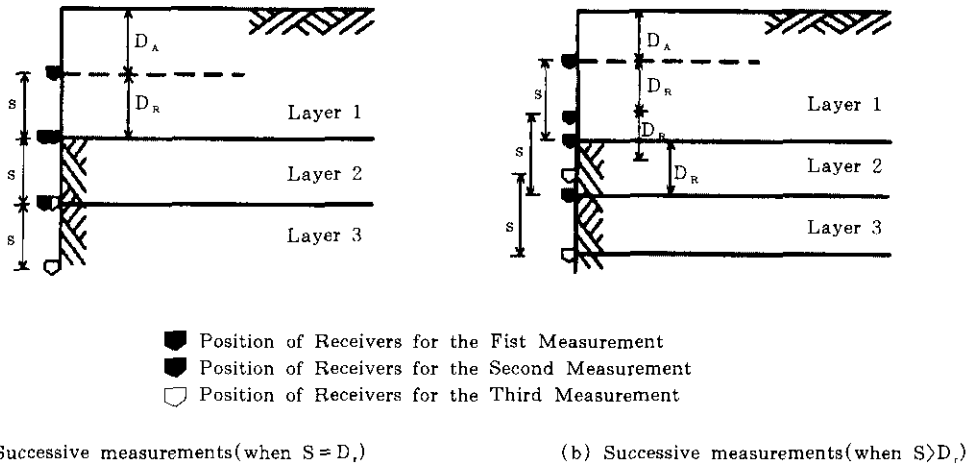

Fig.3 Types of modified interval measurements and assumed layering (Batsila, 1995)

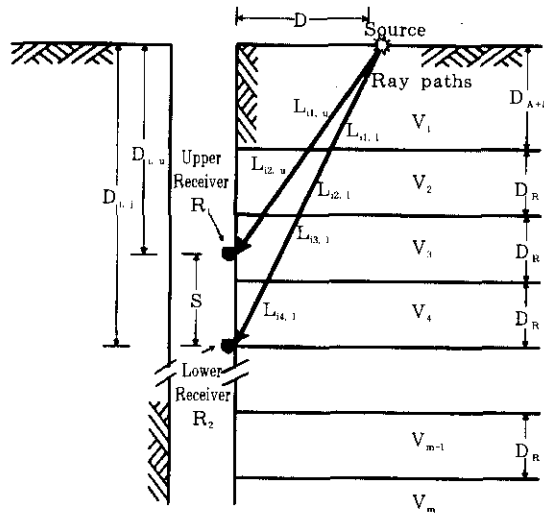

Fig.4 Illustration of the modified interval measurements (Batsila, 1995)

The interpretation of SCPT based on the modified interval measurements is performed by using the following two facts:

1. The travel time of a shear wave from a source to a receiver is determined to be the sum of each travel time for a ray path segment corresponding to each assumed layer. The travel time of a shear wave to reach an upper receiver and a lower receiver from a source can be determined as the following:

$$T_{i,u} = \sum_{j=1}^k \frac{L_{ij,u}}{V_j} \quad (i = 1, 2, 3, \dots, N) \quad (5)$$

$$T_{i,l} = \sum_{j=1}^k \frac{L_{ij,l}}{V_j} \quad (i = 1, 2, 3, \dots, N) \quad (6)$$

where $T_{i,u}$ and $T_{i,l}$ are travel times for an upper receiver and a lower receiver, respectively, and L_{ij} is the segment of the i -th ray path in the j -th layer, and k is the layer where the upper receiver is positioned.

2. The segment of a ray path for the layer i is determined from the following equation :
 j for the first segment of a ray path, that is, $j=1$;

$$L_{i1,u} = L_{i1,u} \frac{\sqrt{D^2 + D_{i,u}^2}}{D_{i,u}} \cdot (D_A + S) \quad \text{for the upper receiver} \quad (7)$$

$$L_{i1,l} = L_{i1,l} \frac{\sqrt{D^2 + D_{i,l}^2}}{D_{i,l}} \cdot (D_A + S) \quad \text{for the lower receiver} \quad (8)$$

where $D_{i,u}$ and $D_{i,l}$ are the depths of the upper and the lower receivers, respectively,

D is the horizontal distance between the source and the borehole wall,

D_A is the depth of the upper receiver during the first reading,

S is the distance between the receivers,

D_A is the thickness of the assumed uppermost layer, and

D_R is the distance between two consecutive readings which is also assumed to be equal to the thickness of the i -th layer for $i=2, \dots, N$.

- j for other segments of a ray path, that is, $j > 1$;

$$L_{i2,u} = L_{i3,u} = \dots = L_{i(k-1),u} = L_{i1,u} \frac{D_R}{D_A + S} \quad \text{for the upper receiver} \quad (9)$$

$$L_{i2,l} = L_{i3,l} = \dots = L_{i(k-1),l} = L_{i1,l} \frac{D_R}{D_A + S} \quad \text{for the lower receiver} \quad (10)$$

From Eqs. 5 to 10, the velocity of a layer i , V_i , can be determined as :

$$V_i = \frac{1}{\frac{D_A + S}{D_R} \left[\frac{T_{i,u}}{L_{i1,u}} - \frac{1}{V_1} \right] - \sum_{j=2}^{i-1} \frac{1}{V_j}} \quad (11)$$

The technique of the modified interval measurements can also be used to interpret SCPT data, although Eq. 11 does not have the term of travel-time difference. The individual travel times for the upper receiver and the lower receiver can be calculated by : 1. evaluating the velocity of the first layer from the travel-time difference measured at the shallowest depth and 2. relating the velocity of the first layer with other travel-time differences (or phase differences).

2.4 New Inversion Technique: Inversion Analysis Using Snell's Law

An attempt for a totally different and unconventional method of data analysis was made by Mok (1987). He developed a method based on inverse modeling; that is, determining the velocity profile whose calculated response best matches the real data. The method uses prediction error and data and model resolution matrices to judge the quality of the solution. Mok showed in his study two cases where his method gave results closer to the results obtained from crosshole tests than the conventional methods of downhole analysis.

In this paper, a new improved inversion scheme was developed. The improvement was made in the inversion algorithm, which makes the solution of the inversion analysis more stable and reliable. However, the modeling algorithm which calculates the travel time of a wave is kept the same. Mok (1987) employed Snell's law to implement a wave propagation. Snell's law is a better choice than the straight ray path assumption, because Snell's law can determine the path of the refracted wave propagating through layers with different shear stiffness.

The schematic diagram for the model used in the inversion analysis is shown in Fig. 4. With the notation in Fig. 5, the ray path for the measurement at the depth of $D(i)$ should satisfy the following:

$$\frac{\sin \theta_{i1}}{V_1} = \frac{\sin \theta_{i2}}{V_2} = \dots = \frac{\sin \theta_{ij}}{V_i} = \dots = \frac{\sin \theta_{ip}}{V_p} \quad (12)$$

$$L_{i1} \tan \theta_{i1} + L_{i2} \tan \theta_{i2} + \dots + L_{ij} \tan \theta_{ij} + \dots + L_{ip} \tan \theta_{ip} = H \quad (13)$$

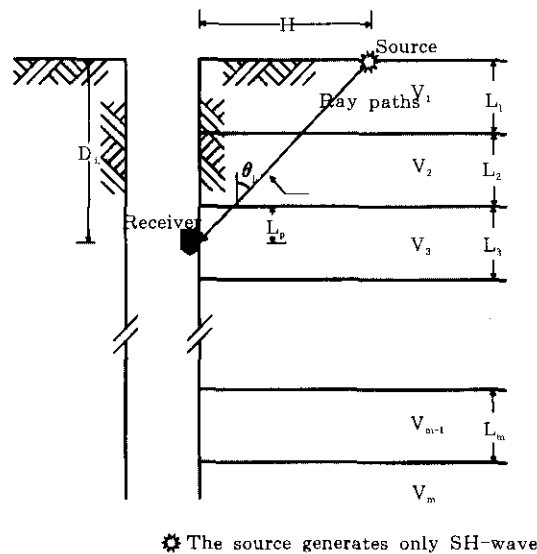

Fig.5 Geometry and notation used in developing inversion method using ray paths based on Snell's law

where index i indicates the i th measurement and index j characterizes layers as illustrated in Fig. 5. The initial guess of the angle, θ_{i1} , is determined from the straight ray path assumption. The other angles, θ_{ij} are calculated from Eq. 12. The left hand side of Eq. 13 is then calculated and is compared with the right hand side. This procedure is iterated with another guess of θ_{i1} until the difference between both sides of Eq. 13 is within a certain tolerance.

Once the ray paths are determined, the relationship between travel times, $t_i (i=1, 2, 3, \dots, N)$, and the assumed velocity profile, $V_j (j=1, 2, 3, \dots, M)$ can be established as

$$\sum_{j=1}^p \frac{L_{ij} / \cos \theta_{ij}}{V_j} = t_i, \quad (i = 1, 2, 3, \dots, N) \quad (14)$$

where p indicates the layer in which the receiver for the i^{th} measurement is located, L_{ij} is the thickness of the a layer, and θ_{ij} is the angle between the vertical line and the ray path.

When the reciprocal of velocity (or slowness) is taken as a model parameter, Eq. 14 can be reduced to the following matrix form:

$$G_{ij} m_j = d_i \quad (i = 1, 2, 3, \dots, N) \quad (15)$$

where

$$m = \left[\frac{1}{V_1}, \frac{1}{V_2}, \frac{1}{V_3}, \dots, \frac{1}{V_M} \right]^T, \quad (16)$$

$$d = [t_1, t_2, t_3, \dots, T_N]^T \quad \text{and} \quad (17)$$

$$G = \begin{bmatrix} L_{11} / \cos \theta_{11} & 0 & \dots & 0 & 0 \\ L_{21} / \cos \theta_{21} & L_{22} / \cos \theta_{22} & \dots & 0 & 0 \\ \vdots & \vdots & \vdots & \vdots & \vdots \\ L_{i1} / \cos \theta_{i1} & L_{i2} / \cos \theta_{i2} & \dots & L_{iM-1} / \cos \theta_{iM-1} & 0 \\ \vdots & \vdots & \dots & \vdots & \vdots \\ L_{N1} / \cos \theta_{N1} & L_{N2} / \cos \theta_{N2} & \dots & L_{NM-1} / \cos \theta_{NM-1} & L_{NM} / \cos \theta_{NM} \end{bmatrix} \quad (18)$$

Using maximum likelihood approach, Eq. (15) can be improved to generate the solution more stable and reliable, and the improved formulation is :

$$m_{k+1} = m_p - (G_k^T C_d^{-1} G_k + C_m^{-1})^{-1} G_k^T C_d^{-1} \quad (19)$$

where m_{k+1} is the parameter at iteration $k+1$, m_p is the initial parameters, C_m is a priori model parameter covariance matrix, C_d is data covariance matrix, and G_k is the matrix of derivatives at iteration k . By solving Eq. 19, a new velocity profile is obtained. This new velocity profile is used to determine new ray paths and again form the G matrix from which a third velocity profile is determined. The above process is iterated until the summation of the squared differences between the measured travel times and the calculated travel times is within a given tolerance.

As with the modified interval measurements, the proposed inversion analysis requires

individual travel times, but the individual travel times can be determined by using the travel-time difference (or phase difference) measurements.

3. Verification of Proposed Interpretation Technique

3.1 Simulation of SCPT with a Synthesized Profile

To verify the proposed interpretation technique for downhole testing, a shear wave velocity profile was adopted as shown in Fig. 6. For the simulation of SCPT, the source was placed 2.5m away from the borehole, the distance between the upper receiver and the lower receiver was 1 m, and the measurements were performed every 1-m intervals. For the shear wave velocity profile in Fig. 6, synthetic travel-time differences between a upper receiver and a lower receiver shown in Fig. 7 were generated by using the ray paths based on Snell's law. The SCPT proposed in this paper measures phase difference, but for the verification purpose, travel-time difference was used rather than phase difference. This is because phase difference is basically the same information as travel-time difference and phase difference can be converted into travel-time difference by Eq. 4, and because travel-time difference method does not include the excitation frequency of the source which is included in the phase-difference method.

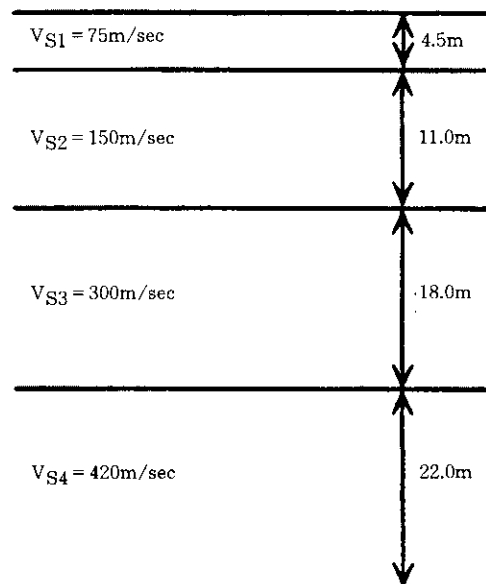

Fig.6 A shear wave velocity profile and measurement setup for the verification of the proposed interpretation technique for SCPT

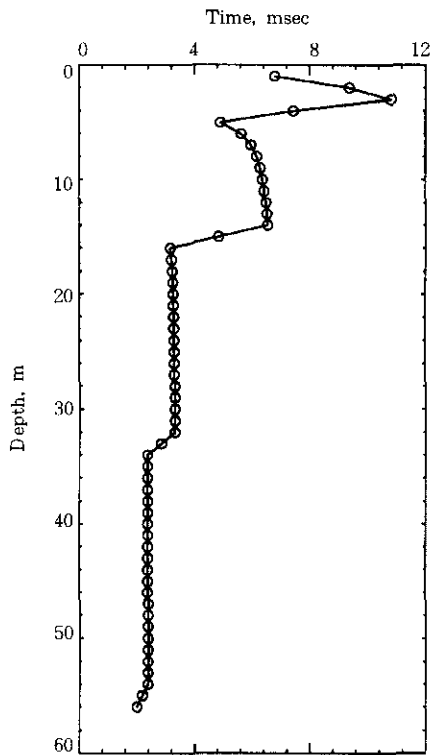

Fig.7 Synthetic travel-time differences between a upper receiver and a lower receiver of a seismic cone generated from the assumed shear wave velocity profile in Fig. 6

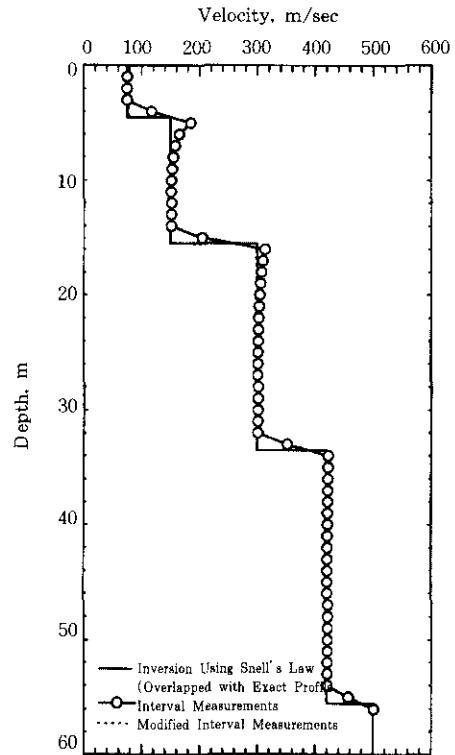

Fig. 8 Shear wave velocity profiles resulting from interval measurements

Three different methods, which include interval measurements, modified interval measurements and inversion analysis using Snell's law, were used to interpret the synthetic SCPT data. In Fig. 8, the resulting shear wave velocity profiles from these three different methods are compared with the exact profile.

For the verification's purpose, the assumed layering used for the interpretation of downhole testign and SCPT, which indicates number of layers and thickness of layers, was exactly the same as the profile used to generate the travel-time difference. From the comparison of Fig. 8, the inversion analysis turned out to be the best scheme to recover the original shear wave velocity profile. The interval measurements are the poorest scheme in evaluating shear wave velocities and the interval measurements are worse near the interface between layers. However, in general, it could be said that the accuracy of the velocity profile obtained with the interval measurements increase steadily with depth, whatever interpretation technique was used. This is because the distance from the source to the borehole can be neglected as the measurement

depths go deeper and the ray path comes to be almost vertical.

4. Case Study

At Pontida, Italy, SCPT testing was performed as part of a study of site characterization by personnel of ISMES, SPA. Two geophones incorporated in the CPT pushing rod were spaced at 1-m, and continuous measurements were made at 1-m depth intervals for a total depth of 25 m of penetration. For the continuous measurements, the source was excited by the vibratory hammer at a certain period. In this case, for the first 12m, the frequency at which the hydraulic hammer was driven was 70 Hz, whereas at greater depths a frequency of 40 Hz offered better quality records. In addition to the continuous measurements, at every 1-m interval, penetration was paused to supply a CPT rod and at the depth SCPT was also performed twice: once with a manual hammer and once with a hydraulic hammer.

The phase difference measured by the continuous SCPT using the vibratory hammer during penetration is shown in Fig. 9. The phase difference was converted into travel-time difference

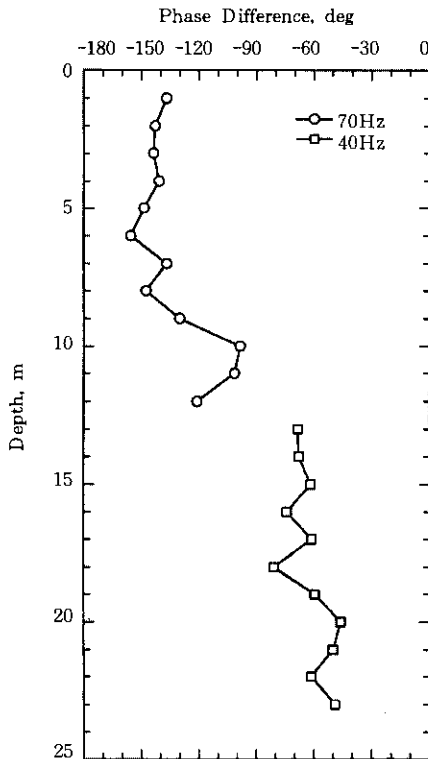

Fig.9 Phase differences measured by SCPT at Pontida, Italy

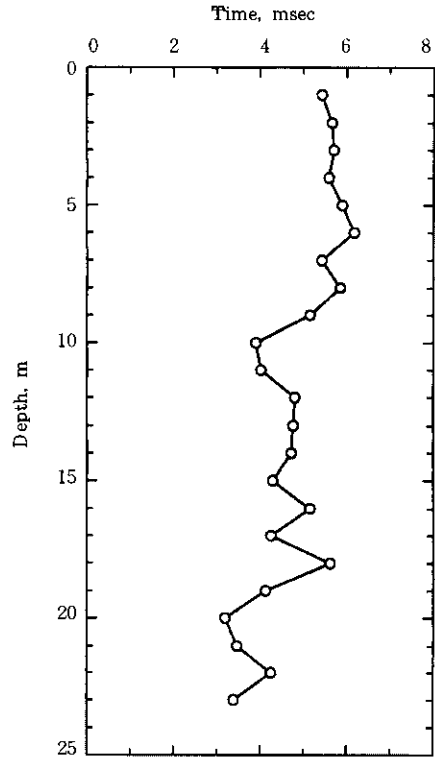

Fig.10 Travel-time differences converted from phase differences shown in Fig. 9 for SCPT at Pontida, Italy

and shown in Fig. 10. The travel-time difference was analyzed to evaluate shear wave velocity profiles by three different methods: the interval measurement, the modified interval measurement and the inversion analysis using Snell's law. The resulting shear wave velocity profiles are shown in Fig. 11.

As in the case of synthetic SCPT data and simulated SCPT at the sand box, the interval measurements give higher velocities at shallow depths. At deeper locations, shear wave velocities determined by all three methods agree well with each other. As the measurement depth is getting deeper, the ray path from the source on the surface to the receiver at depth is getting almost vertical, which makes the assumption on the ray paths negligible.

The SCPT data from the other two measurements performed when penetration was paused to supply CPT rods were analyzed and compared with the continuous SCPT measurements in Fig. 12. From the comparison, measurements taken during penetration appear to be of the same

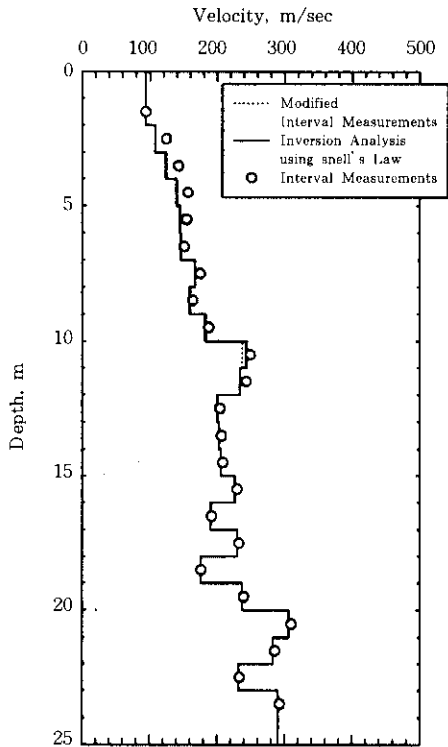

Fig.11 Shear wave velocity profiles determined by interval measurements, modified interval measurements and inversion analysis using Snell's Law for SCPT at Pontida, Italy

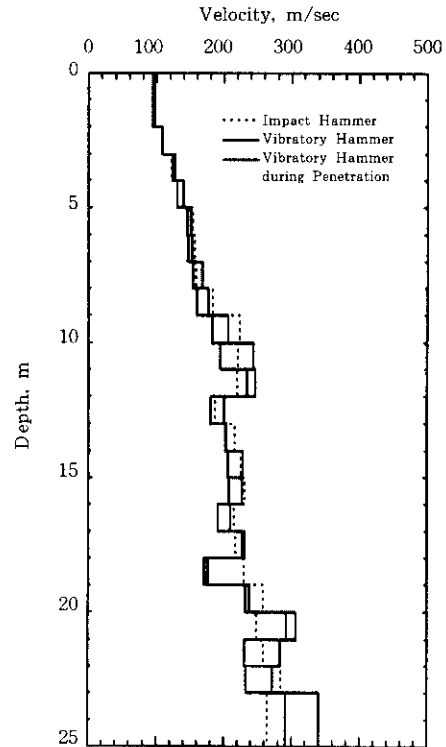

Fig.12 Comparison of shear wave velocity profiles determined by conventional SCPT using impact hammer and vibratory hammer, and continuous SCPT using vibratory hammer during penetration; Pontida, Italy

quality as those taken from discrete measurements. This observation is of great significance. If SCPT were made continuously and provide velocity profiles with good quality, then the time required for test is reduced significantly. Furthermore, a larger amount of measurements can be obtained, increasing the probability of obtaining measurements within thin layers.

5. Conclusion

To analyze the measurements of downhole testing or continuous SCPT, a new inversion procedure is proposed. The new procedure is capable of analyzing the interval measurements, which enables the downhole testing or SCPT to be automated. The forward modeling scheme in the new inversion procedure is based on Snell's law, which is considered the most reasonable ray path theory. To seek for the most optimum shear wave velocity profile, the maximum likelihood method was employed.

The verification of the new inversion procedure was performed with synthesized profiles, and showed that the new inversion analysis is a valid procedure which enhances V_s profiles determined with the downhole testing or SCPT.

References

1. Batsila, Evanthia (1995), *Investigation of Ray Path Assumptions on Downhole Velocity Profiles*, Master Thesis, The University of Texas at Austin.
2. Campanella, R. G., Robertson, P. K., and Gillespie, D. (1986), "Seismic Cone Penetration Test," in Use of In Situ Tests in Geotechnical Engineering, Geotechnical Special Publication, No. 6, Virginia Tech., Blacksburg, VA.
3. Joh, Sung-Ho (1996), *Advances in the Data Interpretation Technique for Spectral-Analysis-of-Surface-Waves (SASW) Measurements*, Ph. D. Dissertation, The University of Texas at Austin.
4. Menke, W. (1984), *Geophysical Data Analysis : Discrete Inverse Theory*, Academic Press, Inc. Orlando, Florida.
5. Mok, Young Jin (1987), *Analytical and Experimental Studies of Borehole Seismic Methods*, Ph. D. Dissertation, The University of Texas at Austin.
6. Richart, F. E., Jr., Hall, J. R., Jr., and Woods, R. D. (1970), *Vibrations of Soils and Foundations*, Prentice-Hall, Inc., New Jersey.
7. Stokoe, K. H., II (1980), "Field Measurement of Dynamic Soil Properties." Presented to the Specialty Conference on Civil Engineering and Nuclear Power, ASCE, Spet. 15-17, Knoxville.
8. Stokoe, K. H., II, and Hoar, R. J. (1978), "Field Measurement of Shear Wave Velocity by Crosshole and Downhole Seismic Methods," Proceedings of the Conference on Dynamical Methods in Soil and Rock Mechanics, Karlsruhe, Germany.
9. 조성호 (1997), "SASW 실험으로부터 강성 주상도를 구하기 위한 역산 기법," 대한토목학회 논문집 제 17 권 3-4호.

(received on May, 4. 1998)