

LOCA Analysis and Development of a Simple Computer Code for Refill-Phase Analysis

Hee Do Ree and Goon Cherl Park
Seoul National University

Hho Jung Kim and Jin Soo Kim
Advanced Energy Research Institute

(Received May 27, 1986)

냉각재 상실사고 분석 및 재충진 단계해석용 전산코드 개발

이희도·박군철

서울대학교

김효정·김진수

한국에너지연구소

(1986. 5. 27 접수)

Abstract

The loss of coolant accident based on a double-ended cold leg break is analyzed with the discharge coefficient (C_d) of 0.4. This analysis covers the whole transient period from the start of depressurization to the complete refilling of the core by using RELAP4/MOD6-EM and RELAP4/MOD6-HOT CHANNEL for the system thermal-hydraulics and the fuel performance during the blowdown phase respectively, and RELAP4/MOD6-FLOOD and TOODEE2 during the reflood phase.

A simple analytical method has been developed to account for the lower plenum filling by approximating steam-water countercurrent flows and superheated wall effects at the downcomer during the refill period. Based on the informations at the time of EOB (end-of-bypass), the refill duration time and the initial reflooding temperature were estimated and compared with the results from the RELAP4/MOD6, resulting in a good agreement.

In addition, some parametric studies on the EOB were performed. The form loss coefficient between upper head and upper downcomer was found to be sensitive to the occurrence of the spurious EOB. Appropriate form loss coefficients should be taken into account to avoid the flow oscillations at the downcomer. The analyses with the six and three volume core nodalizations, respectively, show much similar trends in the system thermal-hydraulic performance, but the former case is recommended to obtain good results.

요 약

原子爐 冷却 系統의 配管 破裂에 根據한 冷却材 喪失 事故를 방출계수 0.4에 대하여 分析하였다. 이 分析은 原子爐 冷却系統의 配管 破裂에 의하여 發生된 減壓부터 爐心 復舊까지의 全 過度 狀態를 包含한다. 系統 熱水力과 核燃料 性能 評價를 위하여 BLOWDOWN 段階에서는 RELAP4/MOD6-EM

코드와 RELAP4/MOD6-HOT CHANNEL 코드를 사용하였으며 REFLOOD 段階에서는 RELAP4/MOD6-FLOOD 코드와 TOODEE2 코드를 各各 使用하였다.

LOWER PLENUM 充塡을 考慮하기 위하여 DOWNCOMER에서 蒸氣-물逆方向 流動과 過熱壁效果를 近似하여 簡單한 解析의 모델이 開發되었다. EOB 發生 時의 情報를 根據로 하여 再充塡持續 時間과 初期 復舊 溫度가 計算되었으며 RELAP4/MOD6에 의한 分析結果와 比較하여 相當한 一致를 보였다.

또한, 早期 EOB 發生에 影響을 미치는 系統變數의 研究가 遂行되어졌다. DOWNCOMER와 UPPER HEAD사이의 摩擦損失이 早期 EOB 發生에 지대한 影響을 미쳤으며 適當한 摩擦損失計數의 選擇을 통하여 早期 EOB 發生을 防止할 수 있었다. 爐心 nodalization이 여섯개인 境遇와 세개인 境遇의 分析 結果가 系統熱水力學的 面에서 類似한 結果를 나타내지만, 좋은 結果를 얻기 위하여 前者의 境遇가 要求된다.

Nomenclature

- A : area (ft²)
- C : heat capacity (Btu/lbm/°F)
- d : hydraulic diameter (ft)
- g : gravitational acceleration (ft/hr²)
- h : heat transfer coefficient (Btu/hr/ft²/°F)
- H : head (ft), or enthalpy (btu/lbm)
- i : inertia (l/ft)
- J : junction
- K : friction factor
- L : legth (ft)
- P : pressure (psi)
- t : time (sec)
- T : temperature (°F)
- V : volume (ft³)
- V : velocity (ft/sec)
- W : flow rate (lbm/sec)
- Z : height (ft)
- δ : liquid film thickness (ft)
- θ : angle
- μ : viscosity (lbm/ft·sec)
- ν : dynamic viscosity (ft²/sec)
- ρ : density (lbm/ft³)
- Gr : Grasgof Number
- Nu : Nusselt Number
- Pr : Prandtl Number
- Re : Reynold Number

- f : liquid
- gas : nitrogen gas
- g : gas or steam
- in : inlet
- o : initial state
- LP : lower plenum
- out : outlet
- p : pressure constant
- RF : reflooding
- S : steam
- w : wall
- ws : wall structure

I. Introduction

The hypothetical large break loss of coolant accident(LOCA) is initiated due to an instantaneous guillotine break of the primary cold leg piping. Because their consequences include the potential for the release of significant amounts of radioactive material, it is the most drastic occurrence which must be against and thus represents limiting design basis accident.

The reactor is assumed to have been operating at a slight overpower condition(102%) with the peak core power density at the maximum allowable value. At the initiation of accident,the loss of off-site power is assumed to be triggered and the reactor will be scrammed; however, core voiding provides sufficient negative reactivity for shutdown decay heat power level. Also the

Subscripts

- c : coolant

steam generators are promptly isolated on the secondary side by closing the turbine steam supply valves and the feedwater valves.

The reactor during LOCA suffers from blowdown, refill, and reflood phases in sequence. In the generic model, the RELAP4-EM¹⁾ blowdown calculation is continued after end-of-bypass (EOB), through the refill period, to the bottom of core recovery(BOCREC),

RELAP4-EM is used to describe the thermal-hydraulic behavior during the blowdown phase, and thus the fluid conditions obtained from the calculation are used as boundary conditions of RELAP4-EM HOT CHANNEL¹⁾ calculation. The RELAP4-EM HOT CHANNEL model is used to determine the first peak cladding temperature that occurs during the blowdown phase, and to establish the temperature profile and the extent of the metal-water reaction. The thermal-hydraulic calculation using RELAP4-FLOOD¹⁾ begins after refill. After RELAP4-FLOOD calculation, the time-dependent fluid boundary condition in TOODEE2²⁾ are taken from the results, and thus TOODEE2 is used to determine both the peak cladding temperature and the extent of metal-water reaction during the reflood period.³⁾ These concepts can be schematically depicted in Figure 1.

The determination of end-of-bypass plays an important role in the LOCA analysis since it provides the time for core-water subtraction and

the application of adiabatic assumption for fuel rod heat-up, both of which are used in the LOCA analysis for the most conservatism. However, the RELAP4-EM may produce, due to some inherent numerical instability, spurious spikes in downcomer flowrates causing earlier occurrence of EOB which is phenomenologically inconsistent. In order to prevent the spurious flow spikes, special considerations must be taken into account. In this analysis, parametric studies by altering the form loss coefficient and the core pressure drop settings were carried out in order to obtain phenomenologically consistent EOB time.

In the refill phase, the primary purpose of continuing the blowdown calculation is to determine the accumulator injection flow rates, and to initialize RELAP4-FLOOD. However, RELAP4-EM needs a tremendous running time just for calculations of the refill duration time and the initial reflooding temperature. Furthermore, it is quite suspect whether RELAP4-EM deals well with the thermal-hydraulic phenomena occurred during the refill period. Then, a simple analytical approach is here considered to develop a computer code for the refill-phase analysis. The model accounts for the lower plenum filling by approximating steam-water countercurrent flows and superheated wall effects at the downcomer, during the refill period based on the informations at the time of the EOB.

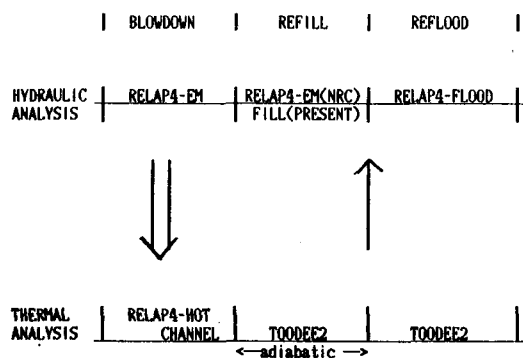

Fig. 1. LOCA Analysis Scheme

II. Evaluation of end of Bypass

Here the spurious EOB is studied to figure out what caused the phenomenon. In addition, some sensitivity studies are performed and recommendation values are presented to avoid the spurious EOB. The important parameters taken into account in this study are form loss coefficient and core pressure drop settings.

2.1 Effect of Form Loss Coefficient

Some potential problems which could encoun-

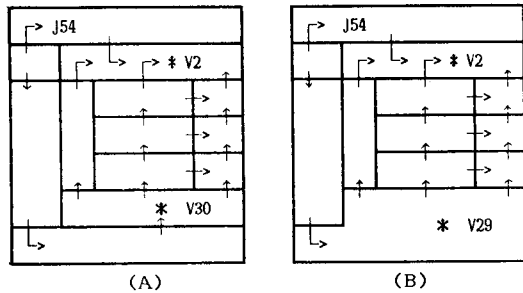

Fig. 2. Volume Nodalization of Vessel

tered in using RELAP4/MOD6 can be overwhelmed by judicious use of options and/or system nodalization. Therefore, it is necessary to determine reasonable values.

For this purpose, the downcomer is separated into two volumes, namely the upper and lower downcomers. And vertical slip option is used at the junction due to the separate noding. The vessel nodalization is shown in Figure 2. The Evaluation Model(EM) logic appears to function properly. The calculation of ECC bypass requires special attentions, when making an EM run, since spurious flow spikes may prematurely signal end-of-bypass. The value of the resistance in junction between the upper downcomer and upper head volumes is difficult to specify correctly. Although the forward and reverse flow loss coefficients for the junction should be large due to complex geometry(head cooling), the loss coefficients in the reverse direction was inadvertently set to zero as a first approach. The problem was later run again for the vertical slip with the reasonable value of junction resistance. This increased the flow resistance in junction between the upper head and upper downcomer volumes and, in turn, provided the core flows shown in Figure 4. It shows that the increased flow resistance in junction between upper head and upper downcomer volumes increases an end-of-bypass time through the direct interconnection between flow resistance and flow rate. Thus this parameter is important and carefully chosen.

In case of zero resistance, the superheated vapor flow into the upper downcomer from the upper head can not be neglected. Thus a significant amount of superheated vapor in the upper head flows through the junction into the downcomer during the blowdown, and the cushion effect of the superheated vapor in the core diminishes, and flow oscillations can occur in the core inlet flow. The effects of the oscillations are propagated through the system and spurious flow spikes in the downcomer may prematurely signal end of bypass.

2.2 Effect of Core Pressure Drop Setting

In the core modeling, the frictional pressure drop of active core is 22.8 ± 4.6 psi.⁴⁾ We should provide the pressure at the center of volume 2 and 30(or 29) as shown in Figures 2~3. This value corresponds to the frictional pressure drop of the active core plus the gravitational pressure drops between the volume 2 and volume 30. EOB is very sensitive to the pressure drop setting between volume 2 and volume 30. In general, pressure drop is directly related to the friction factor. From the above core pressure, the uncertainty of pressure drop is ± 4.6 psi and this corresponds to ± 3.5 of friction factor. In addition, the gravitational pressure drop in the volume 2 and volume 30 are 1.594 psi and 0.560 psi, respectively, as shown in Table 1. These correspond to about 1.5 and 0.5 of friction factor, respectively. The pressure drop between volume 2 and volume 30 is 26.255 psi for the former case, which does not include gravitational pressure drop, and 28.38 psi for the latter case

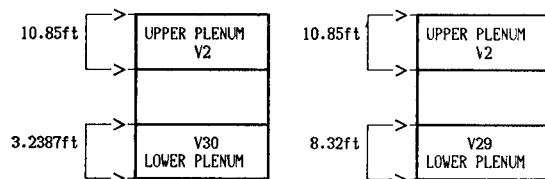

Fig. 3. Gravitational Heads through Various Volumes

Table 1. Gravitational Pressure Drops of Each Volume

Volume	Density (lbm/sec)	A Half of the Volume Height (ft)	Gravitational Pressure Drop (psi)
2	42.3	10.85	1.594
30	42.3	3.2389	0.56
29	42.3	8.32	1.366

Table 2. Summary of Results of the End-of-Bypass Evaluation

Case	Index in Fig. 2	K and I of J54	Pressure Drop (psi)	System Pressure	EOB (sec)
1	A	K=1.223 I=10.	26.25	145.0	14.78
2	A	K=4.0 I=50.0	26.25	74.0	17.16
3	A	K=4.0 I=50.0	28.38	30.0	17.72
4	B	K=1.223 I=10.0	26.25	150.0	14.56
5	B	K=4.0 I=50.0	29.25	15.2	20.2

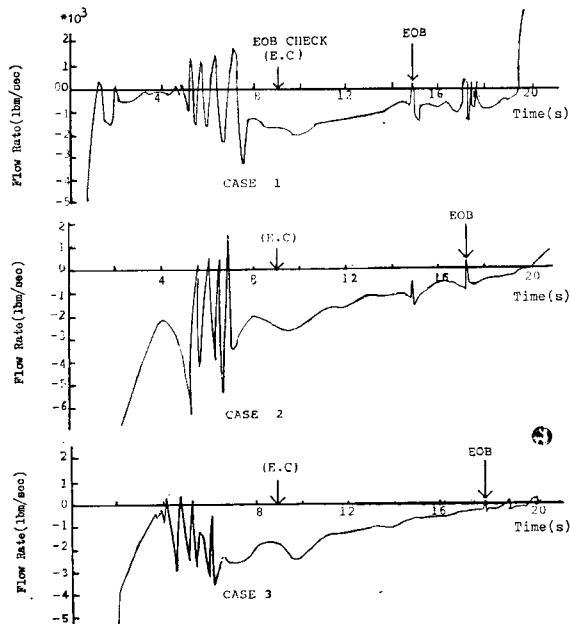
**Fig. 4. Downcomer Flow Rate**

which includes gravitational pressure drop.

As can be seen above, the uncertainty of core pressure drop is considerably great, so that friction factor contains considerable uncertainty.

Therefore, it is desired to establish reasonable core pressure drop settings in order to avoid spurious EOB. The effect of pressure settings on the EOB is shown in Table 2 and Figure 4.

III. Refill Methodology

In order to provide a more continuous ECCS analyses, the capability to perform lower plenum refilling subsequent to a LOCA blowdown has been added to RELAP4-EM. In the generic model, the RELAP4-EM blowdown calculation is continued after end-of-bypass, through the refill period, until BOCREC. The primary purpose of continuing the blowdown calculation through refill is to determine the variable accumulator injection flow rates, and to initialize RELAP4-FLOOD. But, because of the tremendous RELAP4-EM running time, the continuation of RELAP4-EM for detailed calculation through refill is doubtful to calculate just two outputs of refill duration time and initial reflooding temperature. The capability of RELAP4-EM to calculate thermal-hydraulic variables during the refill period is also questionable, since the flow situation is quite complicated due to the presence of two-phase flow throughout the whole system, and the induced unreasonable oscillation may lead to unexpected results. Thus, a simple analytical method is developed to simulate the lower plenum filling by approximating countercurrent flow and superheated wall effects during the refill period.

3.1 Refill Duration Time

The refill calculation starts with known initial conditions, such as, accumulator water available, accumulator gas pressure, RCS back pressure (containment pressure) and volume of water needed to complete the filling of lower plenum, which can be obtained from RELAP4-EM and CONTEMPT-LT.⁵⁾ In addition, the accumulator line flow resistance and area, total accumulator tank volume and SI flowrate should be specified.

The accumulator and safety injection(SI) water from the broken loop is assumed to completely spill through the break for cold leg breaks. For the remaining accumulator, the flowrate is calculated using a momentum equation across the accumulator line. It is further assumed that all of the accumulator water that does not spill to the break flows into the downcomer. During refill, the RCS back pressure is taken to be the containment pressure, and is calculated continuously by CONTEMPT-LT. The accumulator pressure is updated at each time step using isentropic expansion considerations for the nitrogen gas. The SI flow is assumed to be constant. The total water flow from the accumulator and SI is added to the lower plenum. The volume of water injected into the lower plenum is integrated over time and, when the injection water equals the lower plenum volume, recovery is said to occur and reflood calculations are initiated.

The refill period starts when the injection water reaches the lower plenum. This time delay is given as an input to the FILL code which will be described later.

If the incompressible and irrotational state is assumed, the governing and constitutive equations will be given as;

Momentum equation:

$$\frac{L}{A} \frac{dW}{dt} = P_{out} - P_{in} + \rho \cdot g \cdot (Z_{out} - Z_{in}) + \frac{KW^2}{2\rho A^2}$$

Mass conservation for the nitrogen gas:

$$V_{gas}(t) = V_{gas}(t_0) + \int_{t_0}^t W(t) / \rho dt$$

State equation for the nitrogen gas:

$$P_{gas}(t) V_{gas}(t)^{1.4} = P_{gas}(t_0) V_{gas}(t_0)^{1.4}$$

Total time delay

$$\begin{aligned} &= \text{Time delay due to hydrodynamic effect} \\ &+ \text{gravity falling time}(1.1 \text{ sec}) \\ &+ \text{delay time due to thermal effect}(2.3 \text{ sec}) \end{aligned}$$

The last two time delays chosen above are obtained from CREARE experiments⁹⁾ and also the

sum is similar to that of EXXON analysis⁹⁾, 3. 5.

3.2 Initial Reflooding Temperature

The initial reflooding temperature of the average rod in the hot assembly for RELAP4-FLOOD is calculated using TOODEE2 for the hot assembly power of interest(adiabatic process). And the initial temperatures of the RELAP4-FLOOD heat conductors are conservatively taken as their respective temperature at end-of-bypass. In addition, two options are for determining the subcooling of core inlet water. The first option assumes that the inlet water temperature is constant at 150°F (RESAR⁷⁾ & WREFLOOD).⁸⁾ The second is a core inlet temperature which is calculated by the energy balance equation. The model consists of two reference elements which represent lower plenum and the downcomer annulus. For the purpose of this calculation, the downcomer is assumed to suffer from annular until the coolant temperature of the downcomer outlet is less than the saturation temperature. The duration time is calculated to be 3.2sec. After that free convective heat transfer is assumed because the falling velocity is sufficiently low, i.e. less than 1m/sec. And then the perfect mixing is assumed in the lower plenum. The total available metal metal sensible energy is the sum of the heat from the reactor vessel shell and the heat from the reactor vessel internal structures. We assume the steady state heat transfer during refill period. Then, the energy balance equations are given;

$$\begin{aligned} Q_w &= hA(T_w - T_c) \text{ for wall surface,} \\ Q_c &= C_p W(T_{out} - T_{in}) \text{ for coolant,} \\ Q_{ws} &= \rho C_{p,f} V [T_w(t) - T_w(t_0)] \text{ for wall structure,} \end{aligned}$$

where the heat transfer coefficient for the liquid film is obtained from Dittus-Boelter correlation;

$$h = 0.023 * \frac{k}{d} * \left[\frac{\rho V d}{u} \right] * Pr^{0.4}$$

and the hydraulic diameter for the annular flow

is given⁹⁾,

$$d = 4\delta$$

$$\delta / \left(\frac{\nu^2}{g \cdot \sin\theta} \right)^{1/3} = 0.375 \left(\frac{\rho \cdot \nu \cdot \delta}{\mu} \right)^{0.562}$$

For the free convective heat transfer, empirical correlations can be obtained as follows. Over the years, it has been found that average free convective heat transfer coefficients can be represented in the following functional form for a variety of circumstances:

$$Nu = C(Gr * Pr)^m$$

$C=0.21$ and $m=2/5$ is used for the vertical surfaces.¹⁰⁾

At last, the temperature rise in the tower plenum, ΔT_{LP} , due to vessel wall heating is calculated by assuming perfect mixing and using the free convective heat transfer coefficient mentioned above.

Averaged coolant temperature of lower plenum at BOCREC time is obtained from weighting by injection flowrate;

$$\bar{T} = \frac{\int WT dt}{\int W dt}$$

Then, the initial reflooding temperature can be obtained as follow;

$$T_{RF} = \bar{T} + \Delta T_{LP}$$

3.3. Development of FILL code

The refill analysis for KNU-1 and KNU-5 & 6 was performed with the FILL code which was programmed with models mentioned above. The FILL code is composed of a main program and subprograms called ACCU, SAT and SUB.

In The FILL code, volume and pressure are calculated for the nitrogen gas using the mass conservation and the state equation. Mass flow rate is also computed from momentum equation by assuming the loop pressure during the refill period. The subprogram ACCU, where the Euler-Gauss predictor-corrector method is utilized as a computational method, is used to solve the momentum equation in an accumulator.

If the injection water into the downcomer is

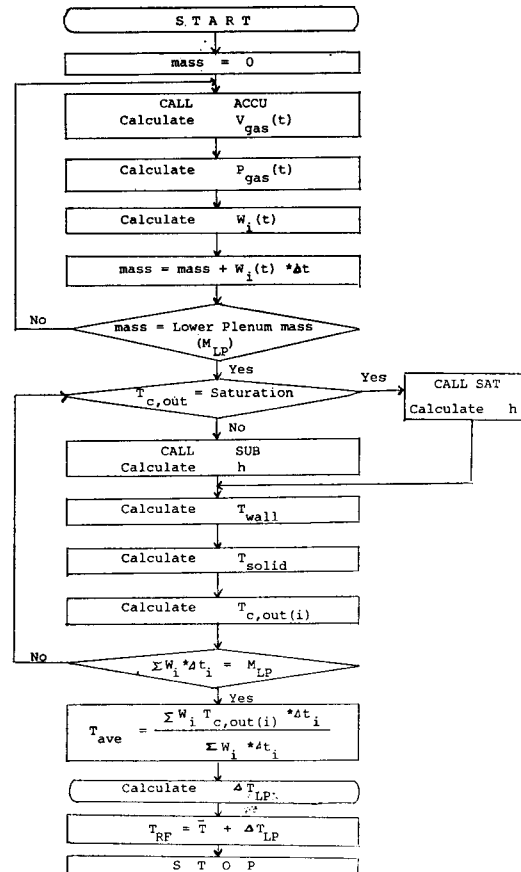

Fig. 5. Flow Chart of Fill Code

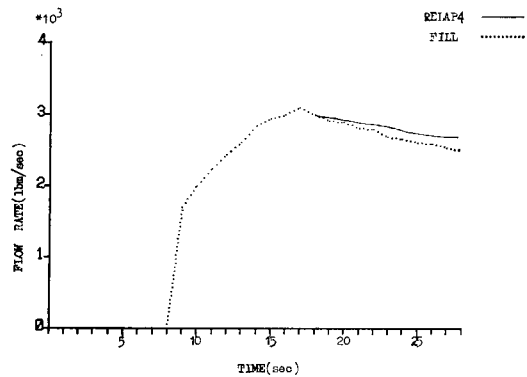

Fig. 6. Accumulator Flow for KNU-1

equal to lower plenum mass, BOCREC is assumed to occur.

Then, the temperature of the heat conductors and coolant are computed using the result of

Table 3. Results of Refill Calculation

		Time(sec)		Refill Duration (sec)	Temperature Increase (°F)
		EOB	BOCREC		
KNU 1	FSAR	19.8	33.4	13.6	—
	Model	17.75	32.5	14.75	61
KNU 5 & 6	FSAR	29.8	43.1	13.3	—
	RELAP	26.8	44.2	17.4	72
	Model	26.8	43.1	16.3	65

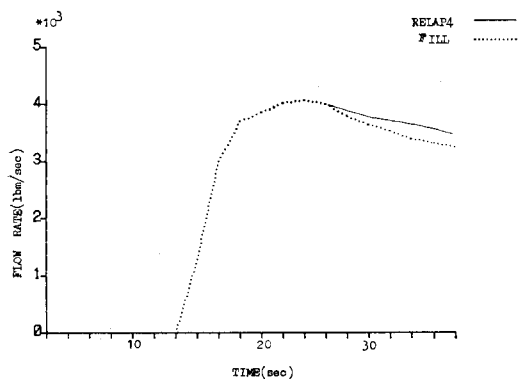

Fig. 7. Accumulator Flow Rate for KNU-5 & 6 above calculation. The subprogram SAT and SUB are used to calculate the heat transfer coefficients during the saturation and subcooled phase, respectively. At first, wall surface and solid temperatures are calculated, and then coolant outlet temperature is computed from these results. Figure 5 shows the flow chart of the Fill code.

The results show good agreements with those from RELAP/MOD6, as shown in Figures 6~7 and Table 3.

IV. Conclusion

Some parametric studies on the end-of-bypass were carried out in order to obtain phenomenologically consistent EOB time, and then recommendation values were presented. The occurrence of the spurious end-of-bypass were found to be sensitive to the form loss coefficient in the junc-

tion between the upper head and the upper downcomer volumes, and to the core pressure drop settings. By altering form loss coefficient and core pressure drop settings, spurious end-of-bypass could be avoided.

During the refill period, the FILL code for the refill time and the initial reflooding temperature has been developed for the sake of saving computation time. It accounts for lower plenum filling by approximating steam-water countercurrent flows and superheated wall effects at the downcomer. The results were compared with those from the RELAP4/MOD6 analysis, and showed good agreements in refill duration time and initial reflooding temperature.

References

- EG & G Idaho Inc., "RELAP4/MOD6: A Computer Program for Transient Thermal-Hydraulic Analysis of Nuclear Reactors and Related Systems" Idaho Falls, Idaho, May 1978.
- G.N. Lauben, "TOODEE2: A Two Dimensional Time Dependent Fuel Element Thermal Analysis Program" USNRC, May 1975.
- Hency, T., et al., "WREM-Based Generic PWR ECCS Evaluation Model, Yankee Rowe Example Problem II," XN-75-41, V. II, Appendix C & D Exxon Nuclear Power Company, August 1975.
- "Ko-RI Nuclear Power Plant Unit No.1, Final Facility Description and Safety Analysis Report," Korea Electric Power Company, 1978.
- Hargroves, D.W., et al., "Contempt-LT/028-A Computer Program for Predicting Containment

- Pressure-Temperature Response to a Loss-of-Coolant Accident," NUREG/CR-0255, March 1979.
6. Crowley, C.J., et al., "Sensitivity Study of Countercurrent Flow and Heat Transfer Effects in a PWR downcomer," TM-637, CREARE Inc., 1979.
 7. "Reference Safety Analysis Report," Westinghouse Electric Co., 1972.
 8. Collier, G., et al., "Calculational Model For Core Reflooding After a Loss of Coolant Accident" Westinghouse Electric Co., June 1974.
 9. Bankoff, S.G., et al., "Local Condensation Rates in Nearly Horizontal Stratified Countercurrent Flow of Steam and Cold Water" AIChE Symposium Series No. 225, Vol. 79, pp. 209-223, 1983.
 10. Holman, J.P., "Heat Transfer," McGraw Hill Book Co., 1981.