

《Technical Report》 Development of Neutron Sensitive PCP Ionization Chamber

Hee Young Lee and Jin Kon Kim

Korea Atomic Energy Research Institute, Seoul, Korea

(Received January 15, 1974)

Abstract

A neutron sensitive ionization chamber has been successfully developed by an improved technique for reactor instrumentation. This instrument is 50mm in diameter and 87cm in length, and can yield a current of $14\mu\text{A}$ when in a neutron flux of around 10^9nv . The normally required voltage is $+350\text{V}$. The instrument may be removed from operating flux and disassembled immediately without special precautions from radiation.

요 약

원자로계장(原子爐計裝)을 위해서 중성자에 민감한 전리함을 개량된 기술에 의해서 성공적으로 개발하였다. 이 전리함은 50mm의 직경에 87cm의 길이를 가지고 있으며 대략 10^9nv 의 중성자속(中性子束)에 대해서 $14\mu\text{A}$ 의 전리전류를 흘릴 수 있다. 요구되는 정상전압은 $+350\text{V}$ 이다.

이 전리함은 동작중의 원자로에서 집어낼 수 있으며 또한 방사선에 대한 별다른 주의 없이 즉시 분해할 수 있다.

1. Introduction

Originally, Abele and Gundlach¹⁾ have developed the neutron sensitive Parallel Circular Plate (PCP) ionization chamber for reactor instrumentation. We have also developed an identical PCP type ionization chamber by an improved technique to indicate the neutron flux level near the normal operating power of reactors and to give this indication with a minimum delay caused by neutron transport time. Test measurement of this instrument has been done in the thermal column of the TRIGA Mark II reactor in the KAERI. This instrument is

thus suited for use in automatic control of reactors and for use in the safety circuitry. The sensitive head of the chamber is designed to make maximum use of a collimated beam of neutrons.

Let us explain briefly the principle of this instrument. When the coated-boron-10 on the each electrode is irradiated by slow neutrons, the following (n, α) reaction is to be taken place.

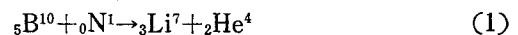

Since nitrogen gas is flowed between two electrodes for high voltage dc, alpha particles can ionize it so as to produce the ionization current, and moreover boron has the advan-

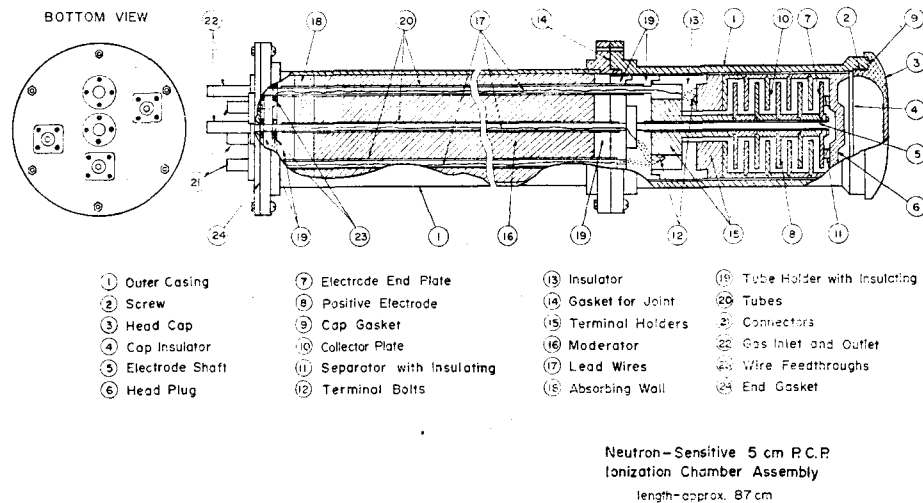

Fig. 1. Sectional view of the PCP chamber.

tage of being much less radioactive than other materials producing charged fragments being similar to alpha particles (*e.g.*, U^{235} or Pu^{239}) after exposure to a neutron field (ref. 2).

2. Description and Making Technique

1) Mechanical Construction

The sectional view of the PCP chamber is as shown in Fig. 1. In the sensitive head of the chamber, collector plate is composed of stacked-dish type five circular plates supported by the negative terminal holder and the head plug, and it is insulated from the outer casing by teflon cloth. The interleaved with these plates are the high voltage positive electrode composing of stacked-hat type five disks which are supported by a few supporters such as the positive terminal holder, the pyrex glass tube shaft, and the several pieces of quartz plate insulator. Electrical connections of lead(Pb) wires are made from this sensitive section through pyrex glass tubings in the graphite body which attenuates the neutron flux gradually to the cable connectors. The collecting volume of the sensitive head of the chamber is roughly calculate d to be around 40 cubic centimeters.

In a PCP type chamber, generally the inner electrode tends to be taken as a collector plate for alleviating the measurement error subject to the sufficient insulating of outer electrode to the positive high voltage. In this development, we took the outer electrode as the collector plate, and the reasons are as follows; (1) Sufficient insulation of positive high voltage between the outer electrode and the outer casing is not easy, (2) Since the negative lead wire connected to the outer electrode is to be grounded through the load resistor on the way of returning to the power supply the insulation between the outer electrode and the outer casing is easy. In this case, the outer electrode and the outer casing are the same potential when the signal current is not flowed.

2) Boron Coating

The surfaces of the electrodes are coated with B-10 to a thickness of around 300\AA after their fine lapping and cleaning. Prior to this coating, natural boron having the B-10 enrichment of 18% was coated first on the graphite surfaces of the electrodes to a thickness of around 200\AA for stabilizing the surface state and for reinforcing the B-10 film to be coated on it. Natural boron was

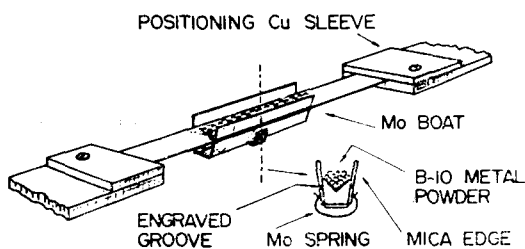

Fig. 2. Schematic illustration of the Mo boat positioning with mica edges in a vacuum coater.

coated by the process of thermal decomposition of B_2O_3 powder in a vacuum coater. Film thickness was measured by the Sloan thickness gauge attached to the coater.

According to Safford³⁾, a crucible type carbon boat with two Mo sleeves was used for the coating of B-10 metal powder. It seems that the use of such a boat is difficult in an ordinary vacuum coater on account of its high current capacity.

In this case, we used an ordinary Mo boat having slightly elevated mica edges as shown in Fig. 2. These mica edges can keep the charged B-10 metal powder on the boat from the spilling at the starting of the heating. After the metal powder has been fired to a certain high temperature, no more spilling and scattering were observed. Since the mica edges having their pre-engraved groove lines can be easily removed away by their self-bendings due to the heating, evaporation of the mica material can be avoided. The evaporation of B-10 was started from the bottom face of the charged metal powder on the boat at a certain high value of the current. Since the fired B-10 cake layer on the concaved part of the Mo boat had a pretty high current capacity, the concaved part could endure from the melting. The flat parts of the Mo boat were not melt as they were connected with two positioning copper sleeves having their large heat capacities.

The enrichment of B-10 in the boron metal powder was 92%.

3. Detail

(a) Choice of Materials

Considerable attention had to be given to the selection of materials for the ionization chamber to be used in a reactor. It is required that the materials of the chamber in a moderately high flux are not subject to radiation damage. Further, it is required that the materials be not sufficiently radioactive to contribute appreciably to the ionization current over the range of operation of the reactor, and the combination of cross section and half life of the materials in the chamber is such that the chamber may be disassembled and serviced within a short time after it has been removed from the reactor.

In the sensitive head of the chamber only materials of high purity and low thermal neutron cross sections are used. Main materials exposed to the collecting volume is graphite having reactor grade purity. Aluminum is used for the outer casing instead of magnesium as it is not available. Lead (Pb) wire is used wherever electrical connections are made. Pyrex glass, quartz, and teflon are used as insulators. Pyrex glass tube is used instead of fused quartz tube as the suitable size of the latter is not available. In the graphite body of the chamber, three pyrex glass tubes are pierced through the body, and around one third of the body length is filled with the graphite of reactor grade, and the rest of the length is filled with a solidified graphite made of its powder with some paraffin binder. A thick duralumin disk as an absorbing wall placed behind the graphite body serves to further reduction of the neutron flux at the end of the chamber so that conventional brass connectors and brass hose jointers can be used. The major part of the materials used in the chamber

Table 1. Bill of material used in Each part of the PCP chamber

Part No	Description	Materials
6	Head plug	Graphite
7	Electrode end Plate	"
8	Positive electrode	"
10	Collector plate	"
15	Terminal holders	"
16	Moderator	"
4	Cap insulator	Teflon
13	Insulator	"
19	Tube holders with insulating	"
5	Electrode shaft	Pyrex glass
20	Tubes	"
11	Separator with insulating	Quartz
9	Cap gasket	Rubber
14	Gasket	"
23	Wire Feedthroughs	"
24	End gasket	"
1	Outer casing	Aluminum
3	Head cap	"
18	Absorbing wall	Duralumin
12	Terminal bolts	Brass
21	Connectors	"
22	Gas inlet and outlet	"
17	Lead wires	Lead(Pb)

are the graphite and aluminum except a little quantity of brass and lead (Pb) materials. The thermal neutron cross section in the graphite (allotrope of carbon) is very small, and the half life of the aluminum nuclide Al^{28} having almost 100% abundance in the metal is only 2.27 minutes, so that the induced radioactivity seems to be in a scope of safety handling if the materials are cooled for a short time after the removal of the chamber from the operating flux. The materials used at each part are as shown in

Table 1.

(b) Disassembly

For disassembly it proceeds as follows: Unscrew the six pairs of bolt and nut at circular end plate and open it at end gasket (24) and then unsolder the three soldered points. Unscrew head cap (3) and take out cap insulator (4). Unscrew the six pairs of bolt and nut at the middle joint and open it at the gasket (14) and then remove the outer casing (1) of the sensitive head by pushing the head plug (6). Pull out the sensitive head from the graphite body carefully with the connected three lead wires (17).

To disassemble the sensitive head of the chamber, remove the outer clothing of teflon insulator and take off the head plug (6). By taking off the quartz stopper attached with a few spots of epoxy at the head side end of the electrode shaft, electrode end plate can be removed first and then each of the collector plate and the electrode plate can be disassembled by turns. Care should be taken in handling the boron-coated parts of each plate. Each part of the chamber before the first assembly is as shown in Fig. 3.

(c) Assembly

For assembly, the above procedure is reversed. Before reassembly all insulators should be cleaned and all dust and lint removed from all parts. All insulators can be cleaned by washing in a good detergent and finally drying by electric hot air dryer. After insulators are cleaned they should not be handled on their insulating surfaces with the hands. If any resoldering is done the soldering paste must be removed by alcohol. The whole assembly including the power supply and others are as shown in Fig. 4.

(d) Laboratory Testing

Before the complete assembly to be inserted in the casing (1), a continuity test with an ohm tester should be made among the lead

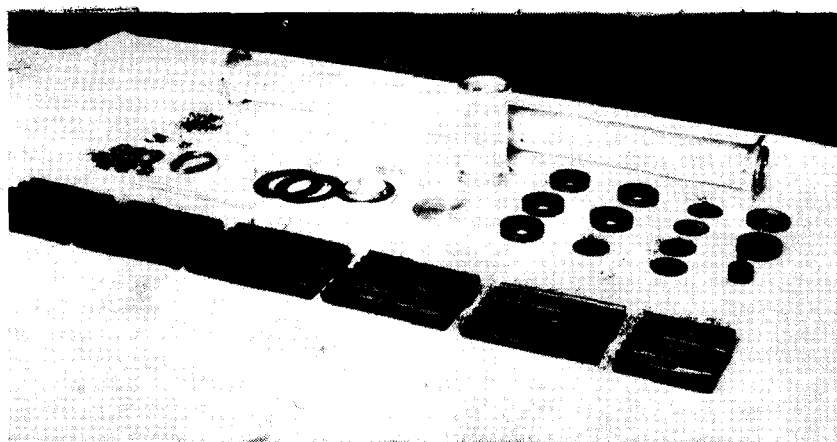

Fig. 3. The photograph of each part of the PCP chamber before the first assembly.

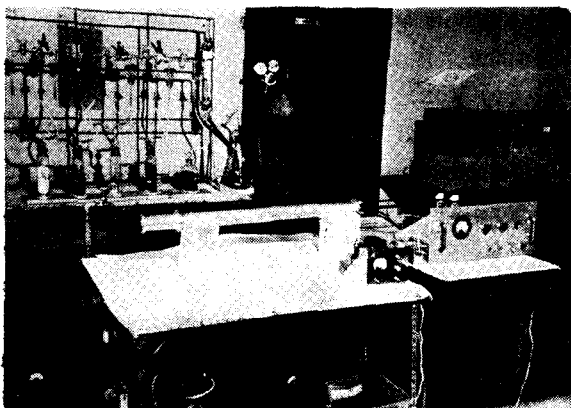

Fig. 4. The photograph of the assembled PCP chamber including the power supply and others.

(Pb) wires. After the assembly is in casing (1), all connectors should be checked again for shorts to the outer casing or to each other. A continuity of less than 10 ohms should be detected between the two high voltage connectors which are both connected to the positive terminal holder. The insulation test was done by 1,000V dc megohm tester. The result of the test in the chamber is as shown in Table 2.

As has been stated in Part 2-1) the outer electrode (collector, N) and the outer casing C are the same ground potential when the signal current is not flowed. Since the signal voltage to appear across the load resistor which will be connected between N

Table 2. Insulation test in the PCP chamber

Between P and N	3.0MΩ
// P and C	2.8MΩ
// N and C	2.0MΩ

P Positive Lead Wire
 C Outer Casing
 N Negative Lead Wire

and C should be very low (less than a few dozens of volts), the leakage current due to a low voltage dc was also tested. When 34V dc was applied between N and C, the leakage current was around $2 \times 10^{-4} \mu\text{A}$. Although the variation of the insulating properties of the insulators according to the magnitude of applied dc voltage is not clearly known, above value of the leakage current at the voltage will be enough to back up the result of the measurement in the reactor to be mentioned later on.

If it is desired to test that the chamber produces a current under radiation, it may be connected to an electrometer or a VTVM having high input impedance. A small gamma source can then be used to produce an ionization current. If a radium-beryllium or plutonium-beryllium neutron source is available, the chamber will show sensitivity to neutrons provided paraffin or other hydro-

geneous material is placed around the chamber and the source. In this test, we used an americium-lithium neutron source.

3. Test Measurement in Reactor and its Result

1) Location of the Instrument

In case of actual use of the chamber, it is desirable to provide for moving the chamber while the reactor is in operation, so that adjustment in output current can be made. A location should be chosen such that the sensitive forward head of the chamber is in a streaming flux of neutrons. After taking out one graphite block (around 1.27m length) from the thermal column, the instrument was inserted in the hole by the sensitive head foremost so as to reach the end of the hole. After the inserting, a special care was taken with provisions such as steel plug and paraffin plug having their each cable feedthrough, collimator, and lead blocks to prevent radiation streaming. Although the temperature of the instrument is limited to around 70°C, no trouble was found after the measurement. The scene of the measurement in the console room is as shown in Fig. 5.

2) Test Scheme

(a) Block Diagram of the Whole System

The block diagram of the whole system of

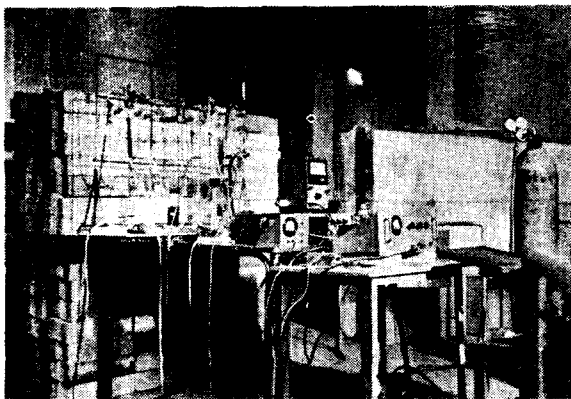

Fig. 5. The scene of test measurement in the console room.

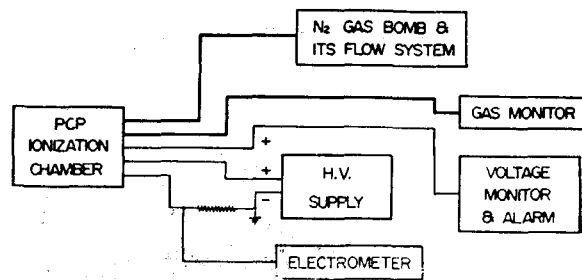

Fig. 6. Block diagram of the whole measuring system of the PCP chamber.

this instrument is as shown in Fig. 6. General description of the whole system has already been aforementioned briefly. Each part of the whole system is to be explained in detail as the following items.

(b) Voltage Supply

The positive voltage on the H. V. positive electrode should be in excess of that amount necessary to achieve a significant degree of saturation; 350V is currently in use. The ordinary power supply is usually adequate from considerations of regulation and noise. For this measurement, we made a vacuum tube type regulated power supply with a voltage divider type breeder which is able to provide the dc voltage range from 280V to 1,500V. An additional connection is made directly to the H. V. positive electrode of the chamber to monitor the positive voltage supply and thus insure reliable operation. The electronic circuit of the H. V. power supply is as shown in Fig. 7.

(c) Gas Flow

A flow of dry nitrogen gas through the chamber is required when used in neutron fluxes near 10^9nv ($14 \mu\text{A}$ chamber current) to avoid the change in saturation characteristics due to contamination of the chamber filling gas. Accordingly, the gas is led into the chamber through central glass tubes in the graphite body and in the positive electrode, and is returned through another glass tube. The gas is purified through the gas flow

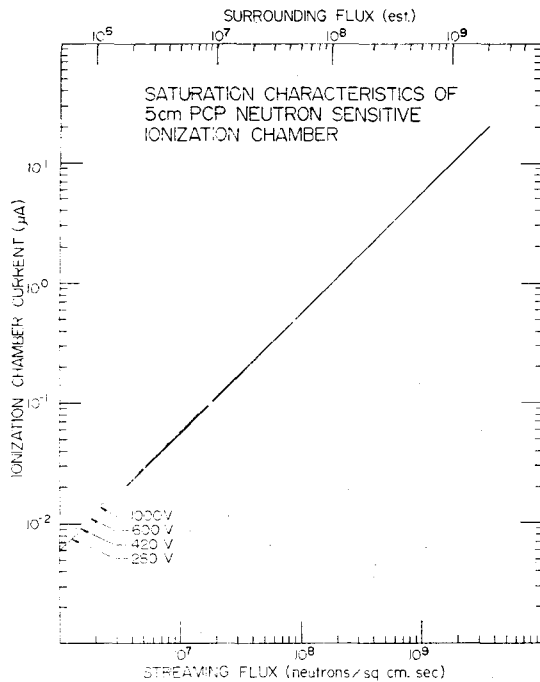

Fig. 9. Saturation characteristics for the PCP chamber in the streaming flux level of 10^9 nv.

maximum output(250KW) of the reactor is estimated to be around 10^9 nv by the advices of the control members.

The measurement was done by varying the H. V. dc at $1.25M\Omega$ of the load resistor, and the highest value was taken to be 1,000V for the safe measurement in leakless condition. The measured data are as shown in Table 3. The curve in Fig. 9 was plotted by the data shown in Table 3 with taking into consideration of the estimated neutron fluxes corresponding to the reactor power output.

The sensitive head of the chamber resulted in a sensitivity of approximately $0.0065 \mu\text{A}/10^6$ nv streaming flux varying to $0.013 \mu\text{A}/10^6$ nv for a surrounding flux where neutrons are reflected by graphite walls around the chamber.

4. Discussions

In Part 2-3)-(d), it is stated that the leaka-

Table 3. PCP chamber current at different applied H. V. dc vs. TRIGA Mark II reactor power output

TRIGA Mark II output	Chamber current at different applied H. V. dc			
	280 V (μA)	420 V (μA)	600 V (μA)	1000 V (μA)
100W	0.0059	0.0060	0.0062	0.0067
500W	0.0280	0.0280	0.0280	0.0238
1KW	0.0552	0.0556	0.0555	0.0600
10KW	0.5600	0.5600	0.5640	0.5680
50KW	2.7600	2.7600	2.7600	2.8000
100KW	5.5600	5.5680	5.6400	5.6800
250KW	14.0000	14.0800	14.1600	14.1600

ge current of around $2 \times 10^{-4} \mu\text{A}$ was measured by applying a dc voltage of 34V between the outer electrode(Ⓝ) and the outer casing(Ⓢ). During the test measurement in the reactor, the signal voltage of 17.7V dc was obtained across the load resistor connected between Ⓝ and Ⓢ at the maximum reactor power output of 250KW. In the present detector system, since we took the outer electrode as the collector, the leakage current between Ⓝ and Ⓢ at above-written reactor power level should be in negligible order, and moreover possible leakage current in the positive electrode will never reduce the signal current.

According to Abele and Gundlach¹⁾, they obtained the sensitivity of around $0.45 \mu\text{A}/10^8$ nv streaming flux, and the collecting volume of their chamber was 140 cubic centimeters. On the other hand, the sensitivity of around $0.5 \mu\text{A}/10^8$ nv streaming flux can be designated on the curve of Fig. 9 although the collecting volume of the present chamber is only around 40 cubic centimeters. If our estimation of the flux level in the thermal column is appropriate another reason which has brought such an improvement should be deeply pursued at further development.

As has been mentioned briefly in Part 2-3), fused quartz should be far better than pyrex glass to avoid the easier metamictization⁴⁾ during the irradiation and to reduce the unnecessary absorption of neutrons due to the boron content as generally be incorporated in the latter, however pyrex glass tube is used instead of fused quartz tube tentatively until we get the suitable size of the tube. Teflon as the main insulating material was excellent for the sufficient insulation and for enduring to the radiation damage.

In Part 2-2), it seems that the boron coating process is an improved method in comparison with the conventional methods including the colloidal dispersion of B-10 in oil(ref. 5). A sputtering technique of B-10 metal has been developed by White and Sheffield⁶⁾, however it seems difficult to adopt this method since krypton gas is used for the environment during the sputtering. As has been stated in Part 2-2), it seems that the coating method of natural boron due to B₂O₃ powder is very easy than the method of B-10 coating due to the metal powder. If we find the B₂O₃ powder made of highly enriched B-10 isotope, the coating of B-10 should be greatly improved.

5. Conclusion

We were able to develop a PCP type ionization chamber as we had expected. Although we made a little smaller chamber in its size than the one which was developed by Abele and Gundlach¹⁾, the efficiency of the instrument was fairly favorable. It seems

that such a smooth development is attributed to a new method of B-10 coating which is developed by us during this research. We were also able to propose a hint on a prospective better method of B-10 coating through our experience during this development. The instrument can be utilized for reactor instrumentation whenever it is required to use, and moreover we could thoroughly acquire the necessary technique for the mass production of the instrument.

Acknowledgment

Authors wish to express their appreciation to Dr. E. Sakai, Chief of Reactor Instrumentation Div., JAERI for his kind present of a reactor grade graphite rod used for this development. We are also grateful to Dr. M. K. Chung, Chief of Neutron Phys. Lab. KAERI for his kind support through the tender of B-10 metal powder and discussions, and to Messrs. Y. P. Lee, C. S. Lee, H. W. Nam, and C. B. Moon, KAERI for their kind assistance throughout the experiments during this development.

References

- 1) R. K. Abele and J. Gundlach, AECD-3494, Sept., (1951)
- 2) G. Barbaras, *et al.*, AECD-2485, Feb., (1948)
- 3) G. J. Safford, *Rev. Sci. Instrum.* 27, 972 (1956)
- 4) W. Primak, *Phys. Rev.* 95, 837 (1954)
- 5) ORNL Instrument Dept., Q-1045-11, "A Boron Coating for Neutron Sensitive Ionization Chambers".
- 6) F. A. White and J. C. Sheffield, KAPL-1827, July, (1957)