

넓은 입력 전압 범위를 갖는 20kW급 양방향 3상 푸쉬풀 컨버터

레뎃탕, 정현주, 김선주, 최세완, *Fellow, IEEE*
 서울과학기술대학교

A 22kW Bidirectional Three-Phase Push-Pull Converter for Wide Voltage Range Application

Tat-Thang Le, Hyeonju Jeong, and Sewan Choi, *Fellow, IEEE*
 Seoul National University of Science and Technology, South Korea

ABSTRACT

In this paper, a bidirectional three-phase push pull converter is analyzed for the high power, wide voltage range applications. From comparison analysis of two switching methods: PWM plus phase-shift (PPS) and dual-asymmetric PWM (DAPWM) with the effect of dead-time, the proposed hybrid control is aimed to reduce the circulating current under wide voltage range operation. Value of leakage inductance effect to the peak current value, current stress and conduction loss in facing the load variation. Trade-off between power range and slew rate of transformer current was analyzed for properly selecting value of the transformer leakage inductance. Experimental results from a 22-kW prototype are provided to validate the proposed concept.

1. Introduction

Recently, high-power bidirectional dc-dc converters with the wide voltage range have aroused much interest in many applications such as energy storage systems (ESS), uninterruptible power supplies, electric vehicles, renewable energy systems, dc micro-grid systems, etc. The three-phase dc-dc converter has several advantages over the single-phase dc-dc converter.

Three-phase dual active bridge (DAB3) have been widely used in some application where the operating voltage range is narrow. Three-phase current-fed dc-dc converters with active clamp have been introduced with the advantages of small current ripple, low conduction loss. Further, by utilizing the active clamp, the current-fed dc-dc converter not only clamps the surge voltage but also has smaller circulating current under wide voltage range. There are two types of bidirectional three phase current fed converters with active clamp: half-bridge [1] and push-pull [2]. Compare to the half-bridge topology, the three-phase current-fed push-pull converter with active clamp [2] has smaller total magnetic volume and core losses of the filter inductor by using only one filter inductor.

The clamp voltage can be controlled by adjusting the duty cycle of low voltage side switches (D_L). The performance of wide voltage range operation is analyzed based on the operating range of D_L . Above topologies with the active clamp circuit tried to widen the voltage range but it is still limited in the medium range of D_L (from 1/3 to 2/3). The power limit problem and dead-time effect on circulating current are rarely

studied in the previous researches, which affect to wide voltage range operation of the converter. The large dead-time is required for preventing the converter from shoot-through during a switching interval especially in the high voltage, high power application, which can makes the converter operate under low efficiency over the wide voltage range.

This paper presents the analysis of a bidirectional three-phase push-pull converter considering the wide voltage range with the full range of D_L . Two switching methods: the well-known PWM plus phase-shift (PPS) and dual-asymmetric PWM control (DAPWM) [23] with the effect of the dead-time are compared considering wide voltage range. Hybrid PPS-DAPWM is proposed for reducing the circulating current. Experimental results from a 22-kW prototype are provided to validate the proposed concept.

1. Two Switching Methods for Bidirectional Three-Phase Push-Pull converter

Fig. 1 shows the configuration of the bidirectional three-phase push-pull converter with the active clamp introduced in [2]. The advantages of the topology include small current ripple on the low voltage side (LVS), low circulating current by controlling the active clamp voltage V_{Cc} . Two switching methods of DAPWM and PPS have been proposed for the bidirectional three-phase push-pull converter and the switching patterns for each phase of the converter are shown in Table I. Fig.2 shows the key waveforms of transformer current in reverse mode according to different duty cycle ranges. The characteristic of forward mode is similar to reverse mode.

In the medium D_L range, both PPS and DAPWM switching

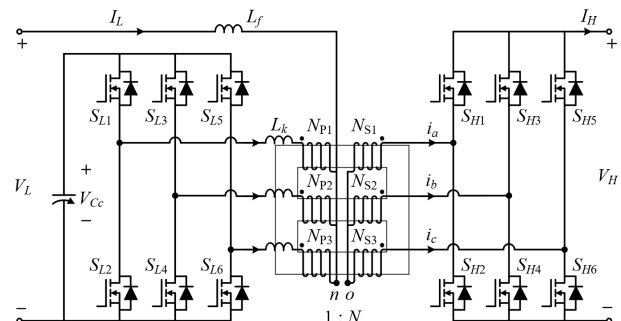
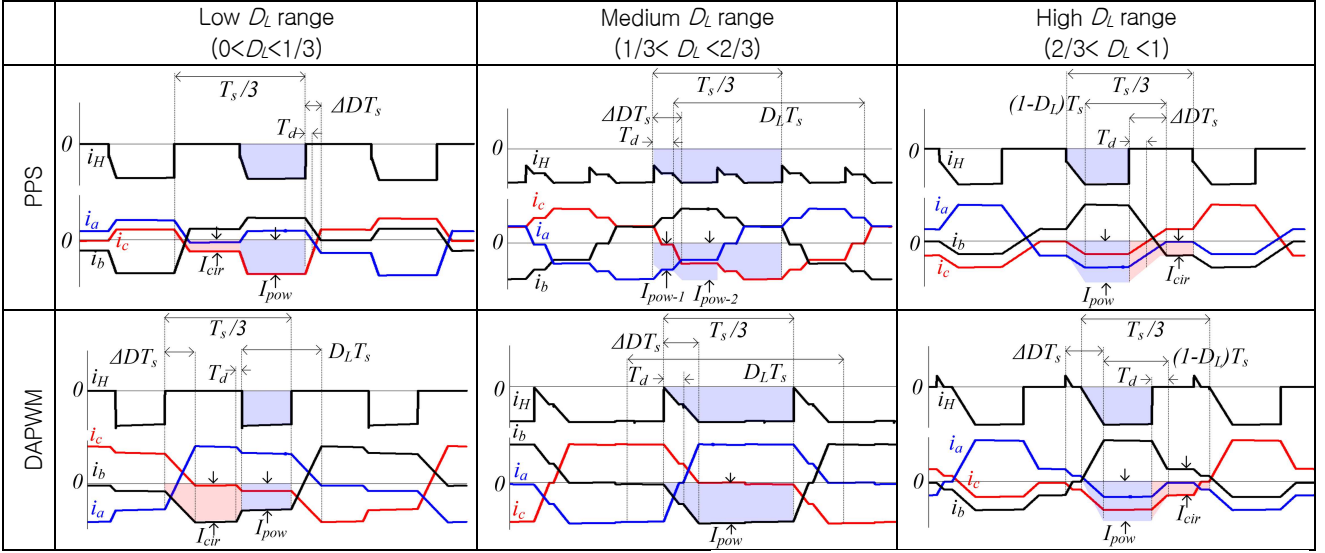

Fig. 1 Configuration of a current-fed bidirectional three-phase push-pull converter [2]

TABLE I. SWITCHING METHODS FOR THE BIDIRECTIONAL THREE-PHASE PUSH-PULL CONVERTER

Switching methods	DAPWM	PPS
Switching patterns		
Control variables	$D_L, \Delta D$	D_L, D_ϕ

 Fig. 2. Key waveform of secondary transformer current, load current with different D_L range of PPS and DAPWM in reverse mode

methods have no circulating current interval. It is seen from current i_H that the power is always being transferred to the load

In the low D_L range, the lower D_L is, the shorter the power transfer interval becomes, resulting in larger circulating current in both switching methods. The magnitude of circulating current i_{cir} of PPS is always smaller than that of DAPWM. Further, the magnitude of power transfer current i_{pow} of PPS is not affected by the dead-time, whereas that of DAPWM is reduced by increased dead-time T_d . Thus, it is concluded that PPS switching method is better to be used in the low D_L range.

In the high D_L range, the larger D_L is, the shorter the power transfer interval becomes, resulting in larger circulating current in both PPS and DAPWM switching methods. When T_d increases, the magnitude of circulating current i_{cir} of PPS becomes larger while that of DAPWM becomes smaller. It means that, in term of large dead-time, DAPWM has more advantages compare to PPS.

2. Hybrid PPS-DAPWM CONTROL

From the comparison of PPS and DAPWM switching methods in the Table II and the comparison of the RMS current of secondary transformer winding over wide voltage range according to PPS, DAPWM, and hybrid PPS-DAPWM controls as shown in Fig. 6, the proposed hybrid PPS-DAPWM control is aimed to reduce the circulating current and

increase the power transfer area in low ($<1/3$) and high ($>2/3$) D_L ranges. Thus, in the low and medium D_L range, the converter uses PPS with the advantages of larger power transfer area and smaller circulating current compared to DAPWM. In the high D_L range, the DAPWM is selected for reducing the circulating current.

The converter operates in constant current (CC) mode when $V_L < 400V$ and constant power (CP) mode when $V_L > 400V$. The mode change between PPS and DAPWM is defined at $V_L/V_{cc}=2/3$. The worst case of RMS current is determined at $V_L=650V$ in high D_L range. It is noted that the proposed

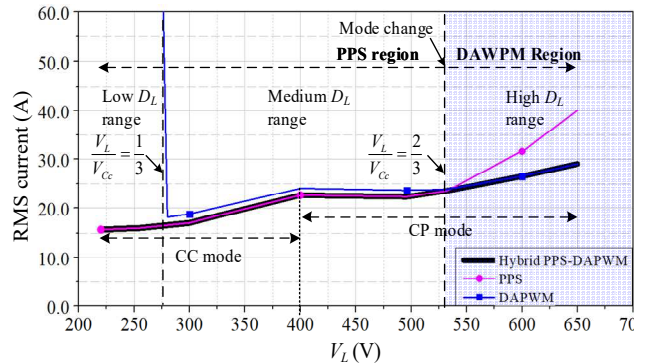

Fig.3. RMS current of the secondary transformer winding over wide voltage range with PPS, DAPWM and proposed hybrid PPS-DAPWM control (CC= 55A, CP =22kW)

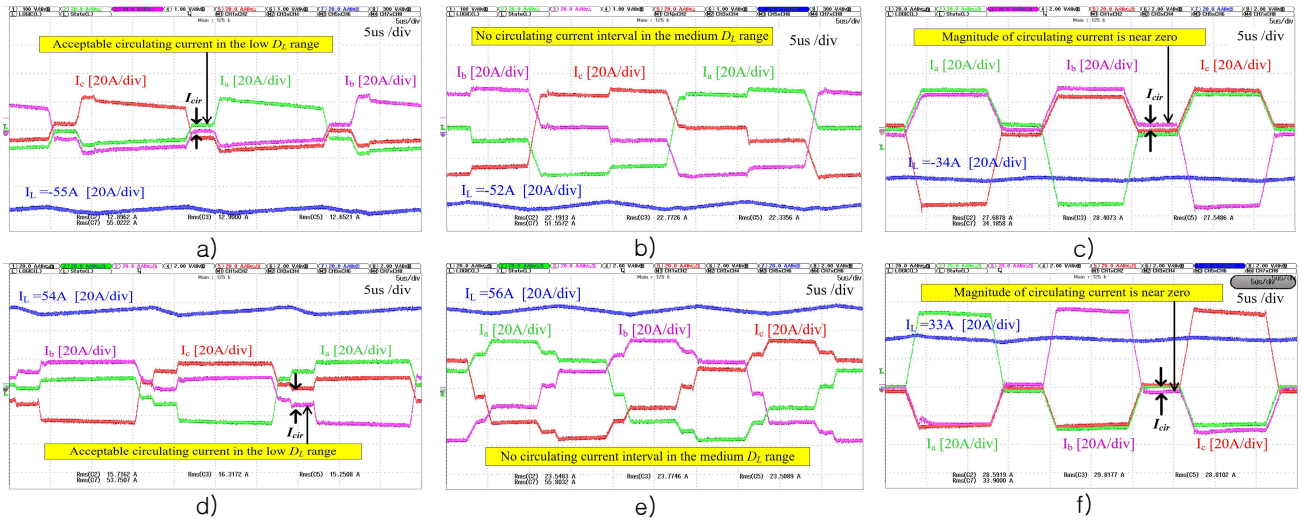

Fig. 4. Experimental waveforms of the filter inductor and secondary transformer current:

- a) Forward, $V_L=220$ V, $P_o=12$ kW, PPS; b) Forward, $V_L=400$ V, $P_o=21$ kW, PPS; c) Forward, $V_L=650$ V, $P_o=22$ kW, DAPWM
d) Reverse, $V_L=220$ V, $P_o=11.8$ kW, PPS; e) Reverse, $V_L=400$ V, $P_o=22.1$ kW, PPS; f) Reverse, $V_L=580$ V, $P_o=22.5$ kW, DAPWM

hybrid control has smaller RMS current by combining PPS and DAPWM switching methods.

4. Experiment results

Table VI shows the parameters of a 22 kW bidirectional three phase push pull converter. The filter inductor and active clamp capacitor are designed based on [2]. The leakage inductance, transformer turn ratio are designed based on [3] for limiting the slew rate of transformer current and minimizing the RMS current. The designed values is listed in Table II.

Figs. 4 shows the experimental waveforms of the converter with the proposed hybrid PPS–DAPWM switching method under the full voltage range of LVS (D_L is from 0.222 to 0.75) in the forward and reverse modes. The full rated power of 22 kW was achieved. **In high D_L range**, the magnitude of circulating current is near zero as shown in Figs. 4(c) and 4(f). **In the low D_L range**, under CC mode operation, the acceptable circulating current due to dead–time is appeared as shown in Figs. 4(a) and 4(d). **In the medium D_L range**, converter operates without circulating current interval. RMS

than the rated current of 30 A. The experiment results are the same as those obtained from calculation and simulation results as shown in Fig. 3.

5. CONCLUSION

This paper presented the analysis of a bidirectional three–phase push pull converter for the wide voltage range operation with the proposed hybrid PPS–DAPWM control. The comparison analysis of two switching methods with the large dead–time time shown the advantage of the proposed hybrid PPS–DAPWM in reduction of the circulating current in the high D_L range. Experimental results from a 22–kW prototype are provided to validate the proposed concept.

REFERENCES

- [1] Z. Wang and H. Li, "A Soft Switching Three–phase Current–fed Bidirectional DC–DC Converter With High Efficiency Over a Wide Input Voltage Range," in IEEE Transactions on Power Electronics, vol. 27, no. 2, pp. 669–684, Feb. 2012.
- [2] M. Kwon, J. Park and S. Choi, "A Bidirectional Three–Phase Push–Pull Converter With Dual Asymmetrical PWM Method," in IEEE Transactions on Power Electronics, vol. 31, no. 3, pp. 1887–1895, March 2016.
- [3] Tat–Thang Le, Hyeonju Jeong, Sunju Kim, and Sewan Choi, "Analysis, Design and Implementation of a Bidirectional Three–Phase Push–Pull Converter for Wide Voltage Range Application" The 2019 International Conference on Power Electronics–ECCE Asia–, Busan, May. 2019, pp. 2880–2885.

TABLE II. PARAMETERS OF 22KW BIDIRECTIONAL THREE–PHASE PUSH–PULL CONVERTER

Items	Symbol	Value
Low side voltage	V_L	220 V–650 V
High side voltage	V_H	745 V
Rated power	P_{max}	22 kW
Rated low side current	$I_{L,max}$	55 A
Switching frequency	f_s	20 kHz
Dead–time	T_d	2.0 μ s
LVS inductor	L_f	300 μ H
Active clamp capacitor	C_C	90 μ F
Leakage inductance	L_k	15 μ H
Transformer ratio (N_s/N_p)	N	13/14

current of whole LVS range under the full load condition is less