

Application of single phase D-Q rotating frame theory in a traction co-phase power supply system

In Kwon Park, Sumek Elimban, Yi Zhang, Rick Kuffel
RTDS Technologies, Inc. Canada

ABSTRACT

The imbalance at the 3-phase side at the railway power supply substation has been a well-known issue. Due to the difference in status of loads at each phase at any given moment, it is difficult to maintain the balance in the 2-phase side of the transformer. Consequently, the 3-phase side also presents a certain level of imbalance as well. A co-phase power supply was proposed as a solution. The real application of such system is gradually expanding, proving the effectiveness of the system. In this paper, the application of the single phase D-Q rotating frame theory was applied to the control of the co-phase power supply system. In addition, the power stack of the system was composed of MMC valves, which offers superior operational characteristics. The effectiveness of the system was verified with a real-time simulation, and the results are presented.

1. INTRODUCTION

Electrified railway systems are now expanding into many different areas. The traditional railway systems such as a high speed train system is taking over more portion of the transportation need. In most of the electrified railway system applications, the electric power supply is on a single phase. However, at the transmission level interface of such power supply system is usually on a three phase system. Thus, the mismatch between the single phase system load and the three phase source has been creating a unique problem; the unbalanced load current at the three phase side. The operator of the railway system attempts to maintain the necessary balance by careful planning of the railway car scheduling, but a certain level of imbalance is inevitable. Depending on the supply condition between the railway operator and the utility company, such imbalance might be tolerated. However, as the circumstance at the utility industries changes, it is likely to see that the issue might become the point of contention between the two sides. A solution has been developed in order to address the issue. The system is usually referred to as a co-phase power system^[1]. The system is usually installed in

between two single phase outputs of the power supply transformer. Then, the device tries to balance the unbalanced load at each of those output terminals. Therefore, at the three phase supply side, the load seems balanced, when the load side is unbalanced to any arbitrary degree. Often the system is constructed by high rating power electronics system. This paper presents a way of implementing the system. MMC valves build the power stack of the system. Then, the control of the system is based on single phase D-Q rotating frame theory. The control principle of the system is presented in the next section. Then, the MMC implementation of the power stack and its connection to the power supply transformer follows. Then, the effectiveness of the system is demonstrated by simulation results.

2. CONTROL PRINCIPLE

The co-phase power supply system is usually composed by a back to back bridge systems. The one side of the back to back bridge system takes charge in maintaining the DC voltage, while the other side of the bridge controls the real power flow. For example, if the other side is injecting power from the DC side to the AC side, consequently the DC voltage begins to drop. Then, the control at the DC voltage regulation side detects the drop and begins to send more power from its AC side, attempting to sustain it. Therefore, the operation of the co-phase power supply system can be separated into two parts. The first part is in charge of the DC voltage regulation, while the other part tries to regulate the real power flow. Figure 1 shows the overall system block diagram.

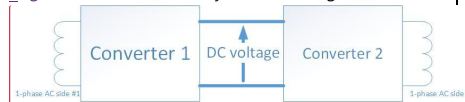

Figure 1 System block diagram

One can assume that the converter 1 in the above block diagram is in charge of the DC voltage regulation, while the converter 2 is in charge of the real power flow. The control of each converter looks different, but the underlying control is the same for both converters. The DC voltage regulation at the

서식 있음: 글꼴: (영어) 맑은 고딕, (한글) 맑은 고딕, 글자 장평: 95%, 축소: 0.25 pt

메모 포함[SE1]: It would be nice to have the figure include the transformer, three phase supply and single phase load.

converter ~~one~~ can be fulfilled by the same real power flow control. Thus the same control principle can be applied to the both converters. The only difference between ~~the~~ two is the high-level control, which is sitting on top of the underlying control. The necessary voltage magnitude and angle can be synthesized by the converters from the control command. A well-known single phase D-Q rotating frame theory^[2] is utilized in the control implementation. ~~Figure 2~~Figure-2 shows the original control block diagram proposed in the reference^[2].

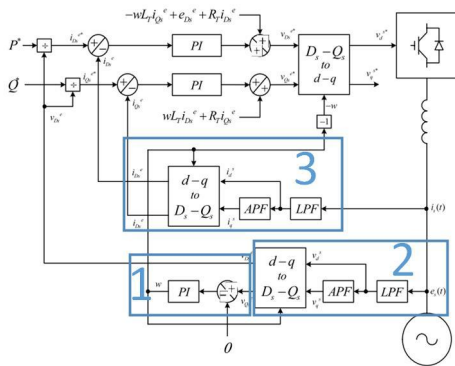

Figure 2 Control block diagram

The block labeled by 1 in ~~Figure 2~~Figure-2 shows the PLL (Phased Lock Loop). The PLL detects the phase information of the AC system. Then, ~~this~~ information becomes the input to the stationary-rotational transformations blocks. The blocks are denoted as d-q to D-Q blocks in the block diagram. Also, the information is utilized in the inverse transformation, which is denoted as D-Q to d-q block in the diagram. The PLL technique used in the above block diagram is a synchronous reference frame technique, where a PI controller tries to yield phase information which would suppress the steady state Q-axis value to zero. In the proposed co-phase system implementation in this paper, a different approach was employed. The technique is usually called as ePLL^[3].

Then, in order to generate the quadrature signals from the incoming single phase signals (voltage and current), the block diagram in ~~Figure 2~~Figure-2 utilizes the APF (all pass filters). The all pass filter approach is the same for the current quadrature signal generation in the implementation, but a different approach was used in the voltage quadrature signal generation. The approach is based on an SOGI filter^[4].

The rest of the control implementation is identical to the block diagram in the ~~4~~Figure 2. The D-axis voltage, after the single phase D-Q transformation, becomes reference for calculating the D-axis and Q-axis current reference. If the converter is taking control of the DC voltage, a higher level control will control the voltage. The output of the ~~higher level~~ control becomes the input to the P control, which is denoted as P* in ~~f~~Figure 2. If the control purpose is to control the real power flow, then the P reference (P*) can directly come from the necessary real power value. The current measurement from the power circuit can be transformed in the same way as the voltage. Then, the same D-Q decoupled control as in the usual 3-phase D-Q decoupled current control ~~ref-P2P[5]~~ can regulate the D and Q axis current. The outcome of the current control is the voltage command. The command is conveyed to the power stack, where the command is converted to the actual voltage magnitude and phase angle. In the co-phase power system implementation in this paper, the power stack is composed of 4 MMC valves at each side. Thus, the voltage command from the controller needs to be translated to the necessary command to the MMC valve. ~~Figure 3~~Figure-3The following figure shows the part of the controller implementation where such translation is performed.

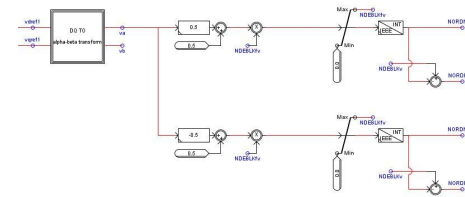

Figure 3 Generating MMC valve control command

3. SIMULATION RESULTS

The proposed co-phase power supply system was implemented and tested in a real-time simulation platform, namely RTDS (Real Time Digital Simulator)TM. The simulation platform offers many different levels of details regarding the MMC valve modeling in the simulation. In this implementation, a model named as MMC5 was selected, mainly due to the simple control requirement of the model. The model is more on the side of the average modeling of the MMC valves, allowing the automatic balancing of the submodule capacitor voltages.

메모 포함[SE2]: Makes sentence a little awkward.

메모 포함[SE3]: In References?

서식 있음: 위 첨자

서식 있음: 위 첨자

서식 있음: 위 첨자

서식 있음: 위 첨자

서식 있음: 글꼴: (영어) 맑은 고딕, (한글) 맑은 고딕, 맞춤법 및 문법 검사 안 함, 글자 장평: 95%, 축소: 0.25 pt

Therefore, the user doesn't need to implement a specific control loop for the capacitor balancing. Thus, the model is suitable for the proof of concept type work which fits the purpose of the implementation in this paper. The load at one single phase output of the roof delta transformer is set as 4 MW. Then, a power meter measures the power. The half of the measured power is given as power order to the proposed co-phase power supply system. Once the system operates expectedly, the 50% of the total power is put on the other single phase output of the transformer, bring the necessary balance at the single phase outputs. Subsequently, the three phase input of the transformer shows a similar balance. The following simulation result screen capture shows such outcome.

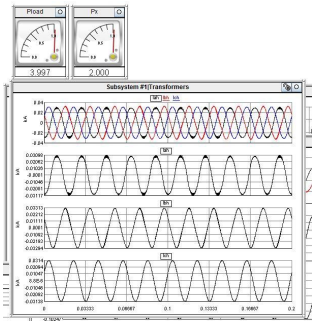

Figure 4 3-phase balanced current waveforms

As obvious from Figure 4, the input side current measurements, i.e., I_a , I_b and I_c , look well balanced. Meanwhile, the two meters at the top of the current plot shows the load power measurement (Pload) and the shared power (Px), which also show the proper operation of the proposed system. Then, the following figure shows the same current plots and the power measurements when the power flow control bridge is disabled (blocked).

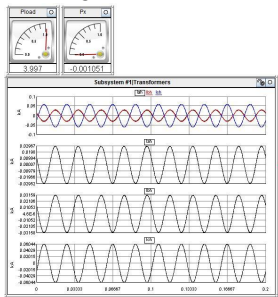

Figure 5 3-phase unbalanced current waveforms

The two power measurement meters shows that the co-phase system is not working. Then, the current plots in Figure 5 show that the three phase input side current waveforms are heavily unbalanced, which is the result of the 4 MW load at only one single phase output of the transformer.

4. CONCLUSION

A co-phase power supply system for railway power supply system is proposed in this paper. The system is based on the MMC valves in the power stack design, while the control system is based on single phase D-Q rotating frame theory. The proper operation of the proposed system was verified by simulation results. It is expected that the MMC based co-phase power system would offer many desirable aspects to the application.

REFERENCE

[1] —Z. Shu, S. Xie, and Q. Li, "Development and Implementation of a Prototype for Co-phase Traction Power Supply System," in 2010 Asia-Pacific Power and Energy Engineering Conference, 2010, pp. 1-4.

[2] —K. Rae-Young, C. See-Young, and S. In-Young, "Instantaneous control of average power for grid tie inverter using single phase D-Q rotating frame with all pass filter," in Industrial Electronics Society, 2004. IECON 2004. 30th Annual Conference of IEEE, 2004, vol. 1, pp. 274-279 Vol. 1.

[3] —M. Karimi-Ghartemani, "Enhanced Phase-Locked Loop Structures for Power and Energy Applications," ed: John Wiley & Sons, Inc., 2014.

[4] —Mihai Ciobotaru, Remus Teodorescu, and Frede Blaabjerg, "A New Single-Phase PLL Structure Based on Second Order Generalized Integrator," in Power Electronics Specialist Conference, 2006. PESC '06. 37th IEEE 2006.

[5] —Fang Zheng Peng and Jih-Sheng Lai, "Dynamic performance and control of a static VAR generator using cascade multilevel inverters," Industry Applications, IEEE Transactions on, vol. 33, no. 3, pp. 748-755, 1997.

메모 포함[SE4]: Not working or not active?

서식 있음: 글꼴: (영어) 맑은 고딕, (한글) 맑은 고딕, 9 pt, 글자 장평: 95%, 축소: 0.25 pt

서식 있음: s0, 양쪽, 들여쓰기: 왼쪽: 0 cm, 첫 줄: 0 cm

서식 있음: 글꼴: (영어) 맑은 고딕, (한글) 맑은 고딕, 9 pt, 글자 장평: 95%, 축소: 0.25 pt

서식 있음: 글꼴: (영어) 맑은 고딕, (한글) 맑은 고딕, 9 pt, 기울임꼴 없음, 글자 장평: 95%, 축소: 0.25 pt

서식 있음: 글꼴: (영어) 맑은 고딕, (한글) 맑은 고딕, 9 pt, 기울임꼴 없음, 글자 장평: 95%, 축소: 0.25 pt

서식 있음: 글꼴: (영어) 맑은 고딕, (한글) 맑은 고딕, 9 pt, 기울임꼴 없음, 글자 장평: 95%, 축소: 0.25 pt

서식 있음: 글꼴: (영어) 맑은 고딕, (한글) 맑은 고딕, 9 pt, 기울임꼴 없음, 글자 장평: 95%, 축소: 0.25 pt

서식 있음: 글꼴: (영어) 맑은 고딕, (한글) 맑은 고딕, 9 pt, 글자 장평: 95%, 축소: 0.25 pt

서식 있음: 양쪽

서식 있음: 글꼴: (영어) 맑은 고딕, (한글) 맑은 고딕, 9 pt, 기울임꼴 없음, 글자 장평: 95%, 축소: 0.25 pt

서식 있음: 글꼴: (영어) 맑은 고딕, (한글) 맑은 고딕, 9 pt, 글자 장평: 95%, 축소: 0.25 pt

서식 있음: 글꼴: (영어) 맑은 고딕, (한글) 맑은 고딕, 9 pt, 기울임꼴 없음, 글자 장평: 95%, 축소: 0.25 pt

서식 있음: 글꼴: (영어) 맑은 고딕, (한글) 맑은 고딕, 9 pt, 글자 장평: 95%, 축소: 0.25 pt