

# Control of Three-Phase Three-Switch Buck-Type Rectifier in EV Rapid Charging Systems

Beomseok Chae and Yongsug Suh  
Dept. of Elec. Eng., Smart Grid Research Center, Chonbuk National Univ.

## ABSTRACT

This paper investigates an economic and highly efficient power converter topology and its modulation scheme for 60kW rapid EV charger system. The target system consists of three-phase three-switch buck-type rectifier topology. A new Carrier Based PWM scheme along with its simple implementation using logic gates is introduced in this paper. This PWM scheme replaces the diode rectifier equivalent switching state with an active switching state producing the effectively same current flowing path. As a result, the distortion of input current during the polarity reversal of capacitor line voltage can be mitigated. The proposed modulation technique is confirmed through simulation verification. The proposed modulation technique and its implementation scheme can expand the operation range of the three-phase three-switch buck-type rectifier having ac input and capacitor ripple current of high quality.

## 1. Introduction

With recent worldwide interest in green energy, various research projects on eco-friendly vehicles, typically electric vehicles (EVs) have gained much interest. EVs do not emit any harmful gasses locally, which has positive impact on air quality in the urban environment and has a positive effect on public health as well [1]. Furthermore, EVs are more energy efficient in terms of kWh/km. In EVs and PHEVs, a battery is used as the main power source, so that battery charger is treated as the core technology [1, 2]. Various topologies and control methods have been developed for EVs chargers. Among these circuit topologies, three-phase three-switch buck-type rectifier is one topology for EV chargers that has just one switch per leg, and single stage structure. Due to the reduced switch count, this structure has the advantage of low cost. In addition, the step-down output dc voltage level is suitable for EV battery charging system connected to standard ac grid. These characteristics of three-phase three-switch buck-type rectifier make this topology one of many feasible candidates for EV charging systems.

Three-phase three-switch buck-type rectifier consists of 4 diodes and one switch per leg [3]. This switch drives converter input current in bi-directional flow. For this reason, three-phase three-switch buck-type rectifier needs a different modulation method from those of conventional two-level voltage source rectifiers. Operation of three-phase three-switch buck-type rectifier depends on various PWM scheme such as Carrier Based PWM (CBPWM) and Space Vector PWM (SVPWM) [4, 5]. However, in the actual realization of the SVPWM algorithms, memory consumption is deliberately sacrificed to achieve a reduction in the

computation time of the algorithm as compared to CBPWM [6]. Conventional CBPWM scheme designed for three-phase three-switch buck-type rectifier has a limited operation range with respect to the power factor angle. This modulation scheme gives an affordable switching action under the operation of unity power factor. However, when the power factor departs from unity, the conventional CBPWM scheme starts to generate switching harmonics and distortion of input current which poses a serious problem in the practical application of three-phase three-switch buck-type rectifier in EV charging systems.

This paper proposes the advanced modulation strategy based on CBPWM. Proposed modulation strategy has a more improved current THD than conventional CBPWM strategy. CBPWM scheme is implemented in this paper with simple digital logic functional blocks. Proposed modulation strategy has a wider operation range than conventional modulation strategy. This wider operating range effectively reduces the distortion of grid current and converter input current of EV charging systems. This paper is structured as the following. In section 2, the operating characteristics of three-phase three-switch buck-type rectifier are described. Section 3 describes the proposed modulation strategy. In section 4, the characteristics of the proposed modulation method are verified by simulation results.

## 2. Operation of Three-Phase Three-Switch Buck-Type Rectifier

In the basic operation of the circuit, the three switches can exercise complete control over the conduction of all the respective branches. There are three states of current commutation, i.e. Freewheeling mode, Two-switch turn-on mode, and Diode rectifier mode (all switches are turn-on). Freewheeling mode corresponds to the case when just one switch is turned on or all switches are turned off. In this mode, the current path is not connected to ac side resulting in a zero switching vector with zero converter input currents. Second, Two-switch turn-on mode implies the case when two out of three active switches are turned on. During this mode the effective current path is determined by the polarity of input capacitor line voltages. That is, the phase with larger supply voltage is connected to the positive bar and the phase with smaller supply voltage to the negative bar of the dc link. Third, Diode rectifier mode represents the case when all switches are turned on. The input phase of largest voltage amplitude is connected to the positive bar and the input phase of smallest voltage amplitude to the negative bar of the dc link. When all IGBTs are conducting, i.e. Diode rectifier mode, the phase currents and switching states depend on the actual polarity of capacitor line voltages.

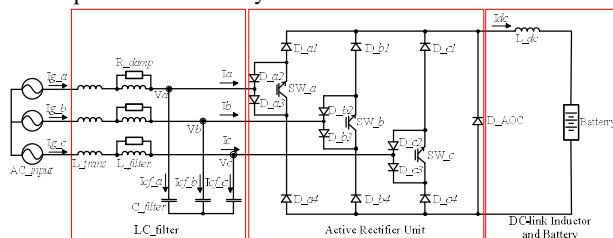

Fig 1 Schematic of three-phase three-switch buck-type rectifier for EV charging system

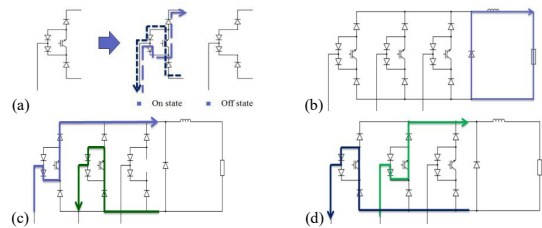

Fig 2 Operation of three-phase three-switch buck-type rectifier (a) switch on-off operation of single leg, (b) free-wheeling mode, (c) active switching mode under  $V_a > V_b$ , (110), (d) Diode rectifier mode under  $V_a < V_c < V_b$ , (111)

### 3. Problem of Conventional Modulation

Input currents are dependent on the relative amplitude of three phase capacitor voltages under the diode rectifier mode having the switching state of (111). The path of current flowing is changed when the polarity of input capacitor line voltage is changed. In  $V_a > V_c > V_b$  condition, a-phase current path is connected to the positive bar in dc-side, b-phase current path is connected to the negative bar in dc-side, and c-phase current becomes zero under in-phase condition. As the voltage condition is changed from in-phase to out-of-phase condition, that is, the angle of input current is not same as that of capacitor voltage, the positive and negative dc-link are connected to different ac phases as compared to in-phase condition. Therefore, the transition of voltage phase conditions may have a crucial impact on the path of current flowing.

### 4. Proposed Modulation Scheme

#### A. Modulation Scheme for Harmonic Elimination

State-of-the-art solutions of the carrier-based PWM for three-phase three-switch buck type rectifier usually maintain turn-on state for the switch of the phase whose current reference amplitude is at median among three phases. In this topology, the modulated current waveforms should be determined by the reference current signals independent of the relative magnitude of filter capacitor phase voltages. However, as the phase angle difference departs from zero to leading side, the pattern of converter input current especially under the diode rectifier mode (111) is altered from that of in-phase condition. This incorrect pattern of modulated converter input current under the condition of leading angle would lead to the distortion of converter input current.

#### B. Proposed Modulation Block

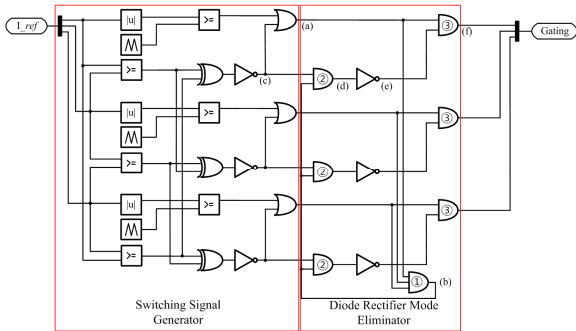

Fig 3 Proposed modulation block

In this paper, the advanced modulation scheme without diode rectifier mode is newly implemented in Carrier Based PWM. The practical implementation of this CBPWM scheme using digital logic gates is presented in Fig. 3. In this figure, Switching Signal Generator is the basic modulator function block in which a modulating rectified sine wave of current reference is compared with a unipolar triangular carrier waveform that conventional gate signal. And Diode Rectifier Mode Eliminator changes the (111) gate signal to (110), (101), or (011) signal. The output of Diode Rectifier Mode Eliminator is proposed gate signal of this paper.

### 5. Simulation Results

The proposed modulation block has been simulated using Matlab Simulink and PLECS. The simulation conditions are summarized in TABLE I. Diode Rectifier Mode Eliminator is also modeled by PLECS.

As a result, the proposed modulation scheme along with the digital logic circuit implementation eliminating diode rectifier mode from the conventional modulation scheme is successfully verified through these simulation results. The waveforms of grid currents and capacitor voltages are described in Fig. 4 and 5 for the cases of conventional modulation and Fig. 6 and 7 for the cases

TABLE I  
SPECIFICATIONS OF CHARGING SYSTEM

Parameters	Value
Rated power ( $P_{rated}$ )	60kW
Rated line voltage ( $V_{l(rated)}$ )	380V
Rated ac input current ( $I_{l(rated)}$ )	117A
Frequency ( $f_{in}$ )	60Hz
Transformer leakage inductance ( $L_{trans}$ )	73.69uH (0.067 pu)
Filter inductance ( $L_{filter}$ )	449uH (0.4 pu)
Filter capacitance ( $C_{filter}$ )	63.48uF (0.1 pu)
Filter resistance ( $R_{damp}$ )	24.05Ω (5.74 pu)

of proposed modulation scheme, respectively. Experimental verification is under progress and the result will be reported in future publications.

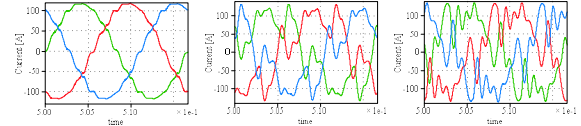

Fig 4 Grid current waveforms under in-phase(THD=4.3%), leading current(THD=47%), and lagging current(THD=50.1%) condition using conventional modulation

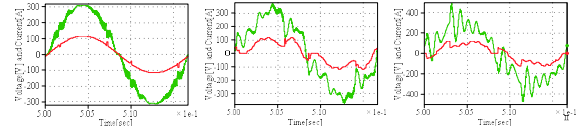

Fig 5 Capacitor voltage and converter input current waveforms under in-phase(THD=5.8%), leading current(THD=22%), and lagging current(THD=34%) condition using conventional modulation

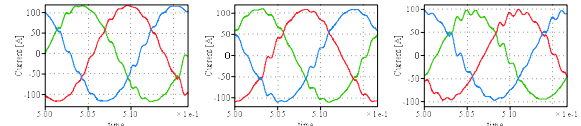

Fig 6 Grid current waveforms under in-phase(THD=4.6%), leading current(THD=5.9%), and lagging current(THD=9.9%) condition using proposed modulation

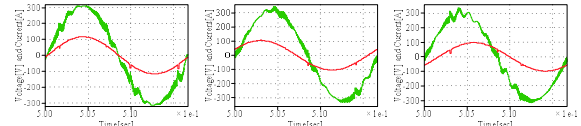

Fig 7 Capacitor voltage and converter input current waveforms under in-phase(THD=6.3%), leading current(THD=5.1%), and lagging current(THD=6.3%) condition using proposed modulation

### 6. Conclusion

The proposed modulation scheme is implemented as carrier based PWM using simple logic gates. The proposed method is confirmed through simulation verification. The distortion of input current observed in the case of conventional modulation schemes is successfully mitigated in the proposed scheme. As a result, the proposed modulation technique and its implementation scheme can expand the operation range of the three-phase three-switch buck-type converter having ac input and capacitor ripple current of high quality.

This work was supported by the National Research Foundation of Korea (NRF) grant funded by the Korea government (MSIP) (No. 2010-0028509) & (No. 2014R1A2A1A11053678)

### References

- C. Oh, D. Kim, D. Woo, W. Sung, Y. Kim, and B. Lee, "A High-Efficient Non-isolated Single-Stage On-Board Battery Charger for Electric Vehicles," IEEE Trans. Power Electronics, vol. 28, no. 12, pp. 5746-5757, Dec. 2013.
- N. Machiels, N. Leemput, F. Geth, J. Van Roy, J. Buscher, and J. Driesen, "Design Criteria for Electric Vehicle Fast Charge Infrastructure Based on Flemish Mobility Behavior," IEEE Trans. Smart Grid, vol. 5, no. 1, pp. 320-327, Jan. 2014.
- M. Salo, "A three-switch current-source PWM rectifier with active filter function," Power Electronics Specialists Conference, 2005. PESC 05. IEEE 36th, pp. 2230-2236, June, 2005.
- S. Kelkar, and C.P. Henze, "A High performance three-phase unity power factor rectifier using interleaved buck-derived topology for high power battery charging applications," Electronics Specialists Conference, IEEE 32nd Annual, vol. 2, no. 3, pp. 1013-1018, Jun 2001.
- T. Nussbaumer, and J.W. Kolar, "Improving mains current quality for three-phase three-switch buck-type PWM rectifiers," IEEE Trans. Power Electronics, vol. 21, no. 4, pp. 967-975, Jul. 2006.
- O. Dordjevic, M. Jones, and E. Levi, "A Comparison of Carrier-Based and Space Vector PWM Techniques for Three-Level Five-Phase Voltage Source Inverters," IEEE Trans. Industrial Informatics, vol. 9, no. 2, pp. 609-619, May 2013.