

보조 전환력 공급의 설계

루오이사오, Dezhi Chen, 권병일  
한양대학교

Design of an Auxiliary Switching Power Supply

Yixiao Luo, Dezhi Chen, Byung-il Kwon  
Hanyang University

**Abstract** - An auxiliary switching power supply is designed for the control circuit of a machine integrated with frequency variation based on TOP249Y in this paper. And experiments have been conducted to verify that this power supply can function well even with fluctuating inputs, indicating the validity of this switching power supply and it can be applied to supply some other electrical equipments.

1. INTRODUCTION

Switching power supply is widely used in home appliances and industry due to its high efficiency and small size [1]. The switching power designed in this paper achieves DC-DC conversion using pulse width modulation (PWM) technique to supply the control circuit for machines. The output of the switching power supply is stabilized by regulating the duty ratio to compensate the disturbance [2]. First the input and output parameters are introduced. After that the operation principle of TOP249Y is analyzed, including the function of all the pins, as well as the PWM generator. Then the modification of switch parameters and design of peripheral circuit are presented [3]. Also the magnetic circuit design of high frequency transformer is introduced. Experiments have been implemented to verify the effectiveness of this switching power supply under different output voltages.

2. Operation Principle and Design

Fig. 1 shows the pin configuration of TOP249Y, including drain pin (D), control pin (C), line voltage detection pin (L), external current limiting circuit (X), frequency pin (F), source pin (S).

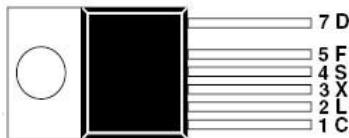

<Fig. 1> Pin configuration of TOP249Y

Fig. 2 shows the switching power supply schematic circuit based on TOP249Y, including the rectifier circuit, filter circuit, PWM generator. It is a single-ended flyback topology inside the power source, which has the function of under-voltage protection, over-voltage protection, external extreme current setting, reducing maximum duty ratio.

2.1 Rectifier, Filter, and Protection Circuit Design

As shown in Fig. 2, the fuse is connected in series with L to provide over-current protection while a thermistor (RT110D-9) connected with N to limit the inrush current. Meanwhile, a varistor (VR1) is connected in parallel with the thermistor to limit the inrush current. Also, a safety capacitor and a bleeder resistor are connected in parallel to avoid electrical leakage caused by the failure of big capacitor. After that an inductor is connected in series and X2 capacitor in

parallel. An electrolytic capacitor is connected with the rectifier bridge in parallel to filter the AC components and harmonics [4].

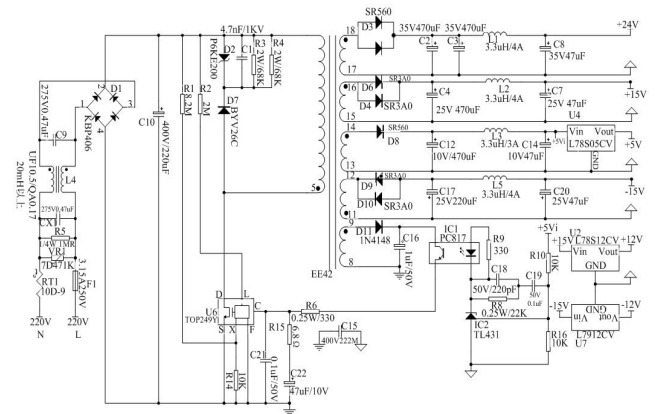

<Fig. 2> Schematic circuit of the switching power supply

2.2 Modification of Switch Parameters and Design of Peripheral Circuit

Resistor R1 can help limit the maximum over-load power with high input voltage by providing voltage feedforward signal which make current decrease as voltage decreases. Resistor R2 help detect the voltage. Since a clamp circuit consisted of R3, C1, D2, D7 can protect the switch, high turns ratio can be used on transformer T1 to reduce the peak inverse voltage on D8. To reduce the cost, a simple Zener detection circuit is adopted. Output voltage is determined by Zener diode IC2 voltage and optical coupler. Resistor R9 provides the bias current flowing into Zener diode, generating a 5% stability under over-voltage or over-load condition[5].

2.3 Design of Magnetic Circuit of High Frequency Transformer

Since flyback converter is quite effective for multiple outputs, it is adopted in this switching power supply. The design of high frequency transformer includes: determination of magnetic core; calculation of minimum input DC voltage; determination of magnetic flux density value; calculation of turns of primary and secondary windings.

Assume that the working frequency is 132KHz, the input is 250V±40% and outputs are ±15V, 1.5A; +24V, 2A; +5V, 1A.

The power can be calculated as

$$P = 15 \times 1.5 \times 2 + 24 \times 2 \times 1 = 98W \quad (1)$$

The sectional area can be calculated as

$$S_a = 0.15 \sqrt{P_1} = 1.6cm^2 \quad (2)$$

and power is

$$P_1 = \frac{P}{\eta} = \frac{98}{0.85} = 115.3W \quad (3)$$

Then magnetic core can be determined as EE42-21-15 based on the number of its output pins. The magnetic flux density during operation can be calculated as

$$\Delta B_{ac} = 0.195T \quad (4)$$

The induced voltage on the primary side can be assumed arbitrarily but it also affects the duty ratio which is

$$D = \frac{V_{OR}}{V_{OR} + V_S} \quad (5)$$

where  $V_S$  is the input voltage on the primary side and  $V_{OR}$  is the induced voltage, and  $D=0.5$ .

Then the number of turns on the primary side can be calculated as

$$N_p = \frac{V_s \times t_{on}}{\Delta B_{ac} \times S_a} = 17 \quad (6)$$

When the output is 5V, considering the voltage drop of diodes and windings, which are 0.7V and 0.6V respectively, then the voltage on the secondary side should be

$$V_2 = 5 + 0.7 + 0.6 = 6.3V \quad (7)$$

Since the voltage per turn on the primary side is

$$\frac{V_S}{N_p} = \frac{150}{17} = 8.82V/turn \quad (8)$$

then the number of turns of the secondary side is

$$N_s = \frac{6.3}{8.82} = 0.71 \quad (9)$$

Since the voltage is low while current is high on the secondary side, half turns should be avoided and to round 0.71 is 1. Similarly, the number of turns on the secondary side for +24V and ±15V can be determined as 3 and 2 respectively. The average input current during one period is

$$I_s = \frac{P}{V_s} = \frac{98}{150} = 0.65A \quad (10)$$

Correspondingly,

$$I_m = \frac{I_s T_s}{t_{on}} = 1.3A \quad (11)$$

$$I_{P1} = \frac{I_m}{2} = 0.65A \quad (12)$$

$$I_{P2} = 3I_{P1} = 1.95A \quad (13)$$

The current variation is

$$\Delta i = I_{P2} - I_{P1} = 1.3A \quad (14)$$

The inductance on the primary side is

$$L_P = V_s \frac{\Delta t}{\Delta i} = 150 \times \frac{7.5}{1.3} = 0.86mH \quad (15)$$

So the inductance constant is

$$A_L = \frac{L_P}{N_p^2} = \frac{0.86}{17^2} = 0.003 \times 10^{-3} \quad (16)$$

Then the size of air gap can be obtained as

$$lg = \frac{\mu_r N_p^2 A_c}{L_P} = \frac{4\pi \times 10^{-7} \times 17^2 \times 178}{0.86} = 0.75mm \quad (17)$$

Finally it is necessary to examine if the transformer designed is qualified or not. The DC component of magnetic induction intensity is

$$B_{dc} = \mu H = 185mT \quad (18)$$

while the maximum value of magnetic induction intensity can be expressed as

$$B_{max} = \mu H = \frac{\Delta B_{ac}}{2} + B_{dc} = 282.5mT \quad (19)$$

Since it can be obtained from the magnetization curve that  $B_s=390mT$ , the designed transformer is qualified.

## 2.4 Experiment

Based on the calculation above, a switching power supply is designed and tested with different output voltages. Fig. 3 shows the photo of designed switching power supply. Fig. 4, Fig. 5, and Fig. 6 show the output voltages of +5V, -15V, +24V respectively.

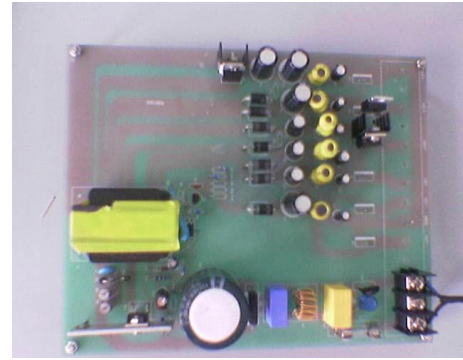

<Fig. 3> Photo of designed power supply

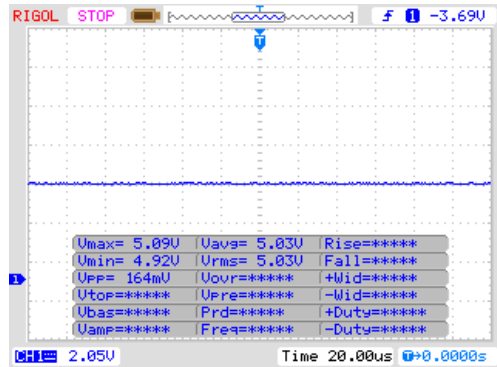

<Fig. 4> +5V output voltage

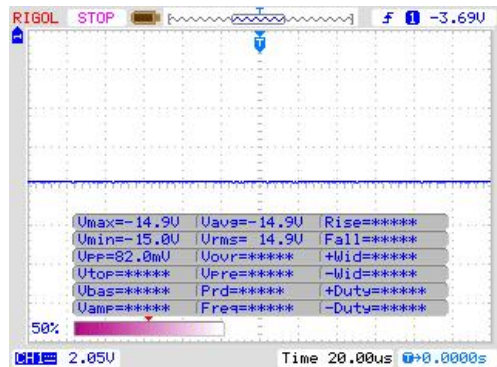

<Fig. 5> -15V output voltage

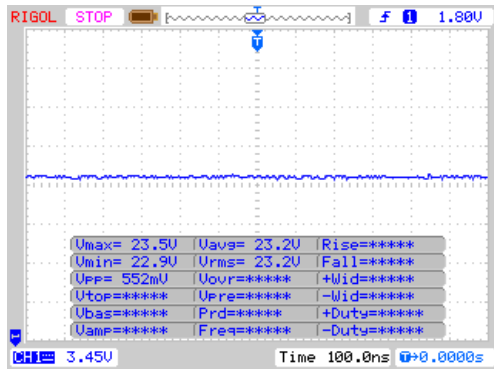

<Fig. 6> +24V output voltage

### 3. CONCLUSION

This paper presents the design of a switching power supply for the control circuit of a machine integrated with frequency variation based on TOP249Y. The operation principle of TOP249Y is analyzed, including the function of all the pins, Then the rectifier, filter and protection circuit are introduced, as well as the modification of switch parameters and design of peripheral circuit. Also the design of magnetic circuit of high frequency transformer is presented. Finally experiments are implemented to test the effectiveness of the designed switching power supply with different output voltages.

This research was supported by BK21PLUS program through the National Research Foundation of Korea funded by the Ministry of Education.

### [Reference]

- [1] Pressman, Abraham. Switching power supply design. McGraw-Hill, Inc., 1997.
- [2] Maniktala, Sanjaya. Switching power supply design & optimization. McGraw-Hill, Inc., 2004.
- [3] Brown, Martin C. Practical switching power supply design. Elsevier, 2012.
- [4] Billings, Keith H., and Taylor Morey. Switchmode power supply handbook. Vol. 2. New York etc.: McGraw-Hill, 1999.
- [5] Chrysis, George. High-frequency switching power supplies: theory and design. New York: McGraw-Hill, 1984.