

AC 직구동 LED를 위한 MOSFET 기반의 위상 제어 조광기

윤혁진*, 김종현**, 류명효**, 백주원**, 김희제*
 부산대학교*, 한국전기연구원**

Phase-Controlled Dimmer Based on MOSFET for AC LED Lamp

Hyeok-Jin Yun*, Jong-Hyun Kim**, Myung-Hyo. Ryu**, Ju-Won Back**, Hee-Je Kim*
 Pusan National University*, Korea Electrotechnology Research Institute (KERI)**

Abstract

본 논문은 AC 직구동 LED를 위한 MOSFET 기반의 위상 제어 조광기에 관한 것이다. 기존의 트라이악을 기반으로 하는 조광기는 트라이악 소자 특성에 많은 영향을 받는다. 트라이악은 래칭 전류와 유지 전류의 특성을 가지고 있다. 특히 래칭 전류는 조광기의 최소 조광 범위를 제한하는 요소로 작용한다. 또한 최대 조광 범위는 트라이악을 구동하기 위한 에너지에 의해 제한된다. 이러한 단점들을 극복하기 위해 본 논문에서는 트라이악이 아닌 MOSFET을 기반으로 하는 조광기를 제안한다. MOSFET은 래칭 전류, 유지 전류의 특성이 없으며 전압 구동 소자이기 때문에 기존의 조광기에 비해서 훨씬 넓은 조광 범위를 가진다. 또한, 제안하는 모델은 기존의 트라이악 기반의 조광기와 핀투핀 호환이 가능하다. 마지막으로 실제 실험을 통해 제안하는 조광기의 성능을 검증하였다.

1. Introduction

The dimmer is a power electronic device for lighting control used in various applications including industrial and residential. The use of dimmers brings many advantages to consumers like convenient and energy conservation. Up to now, the brightness control of AC LED lamp was phase-controlled by using a triac (or two thyristors)^[1]. This dimmers have limitation of lower dimming range due to triac's latching current characteristics. And maximum dimming range is also limited by the energy to drive triac. Because triac is current operated devices so it needs higher energy to drive^{[2], [3]}.

To solve these problems, the proposed dimmer uses a MOSFET instead of the triac. The MOSFET is free from latching current and is voltage operated devices. Therefore, the proposed dimmer can be used as the AC LED lamp's dimmer instead of the conventional phase-controlled dimmer. Furthermore, proposed model is pin to pin compatible with triac dimmer. The experimental result shows that the proposed PWM dimmer has good performances.

2. The proposed phase-controlled dimmer

Fig. 1 shows the basic schematic of the proposed phase-controlled dimmer. Unlike conventional phase-controlled dimmer, which uses triac for lighting control, it uses MOSFET for lighting control. The MOSFET is free from latching current

and is voltage operated devices. Therefore, it is expected that the overall dimming range is increased than conventional one. Furthermore, the proposed model does not need independent driving source. It means that proposed model is pin to pin compatible with conventional triac dimmer.

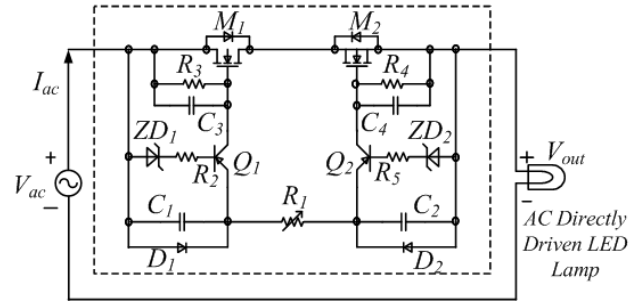
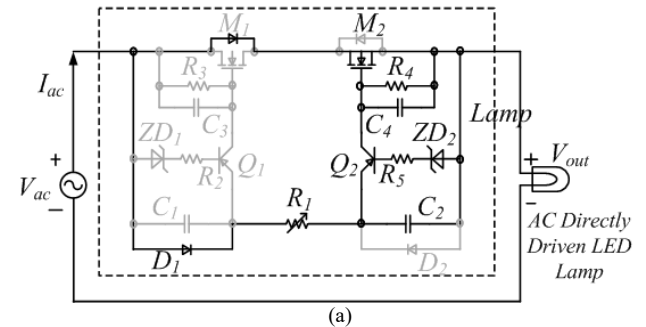

Fig. 1. Proposed phase-controlled dimmer

Fig. 2 shows the operation sequence of proposed circuit. In the positive half-cycle, the diode (D₁) is conducted. And the capacitor (C₂) is charged through variable resistor (R₁). By this RC time constant, phase angle is determined. Transistor (Q₂) is turned on when the charged voltage exceeds the sum of V_{be} and breakdown voltage of zener diode (ZD₂). At this moment, charged voltage (C₂) is transmitted to the gate terminal for driving the MOSFET (M₂). Through this process, stable turn-on voltage is supplied to the MOSFET. Capacitor (C₄) also helps to supply stable driving voltage and resistor (R₄) plays a role in protecting the MOSFET.

The negative half-cycle is equivalent to that of positive half-cycle.



(a)

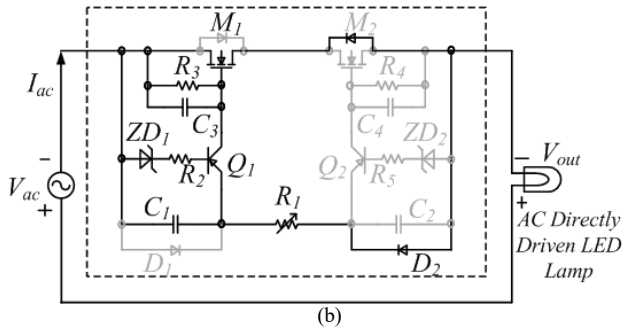
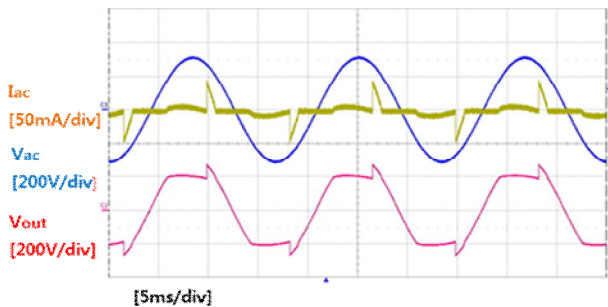

Fig. 2. Operation sequence. (a) Positive half-cycle of the ac circuit. (b) Negative half-cycle of the ac circuit.

3. Experimental result

The proposed circuit is applied to the 8W prototype AC LED Lamp to compare with conventional one. It is good to compare the dimming range under the light load condition since the characteristic of triac is dominant. Fig. 3 shows the experimental result of the conventional phase-controlled dimmer. The minimum dimming range is limited to 21.22% by the latching current of triac. And the maximum dimming range is limited to 92.2% by energy to drive the triac.

Fig. 4 shows the experimental result of the proposed phase-controlled dimmer. It uses MOSFET instead of triac. The MOSFET is free from latching and holding current. So, the conduction of AC LED lamps is possible from zero current. It means that the minimum dimming range is 0%. In addition, the MOSFET is voltage operated device. So, the energy to drive MOSFET is smaller than triac. Therefore, it is expected that the overall dimming range is increased than conventional one. In fact, the overall dimming range is measured to 99.9%. The result of this experiment shows that the dimming range is increased about 28.92% than conventional triac dimmer under the same load condition.



(a)

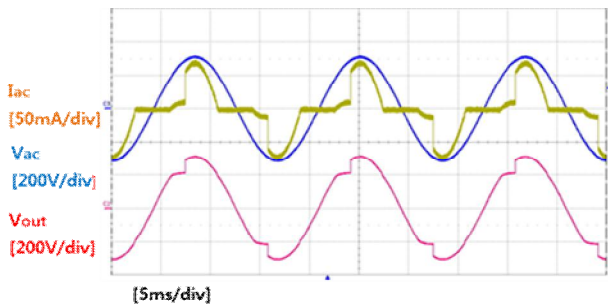

(b)

Fig. 3. Conventional phase-controlled dimmer. (a) Minimum dimming(21.22%). (b) Maximum dimming(92.2%).

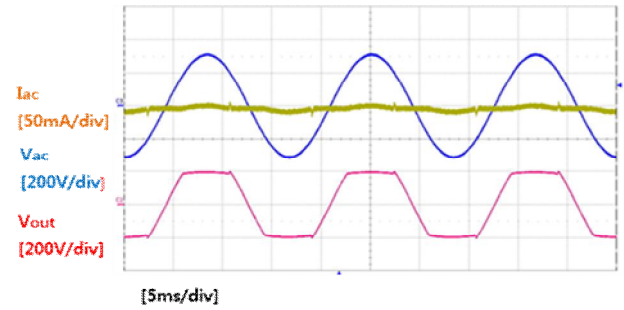

(a)

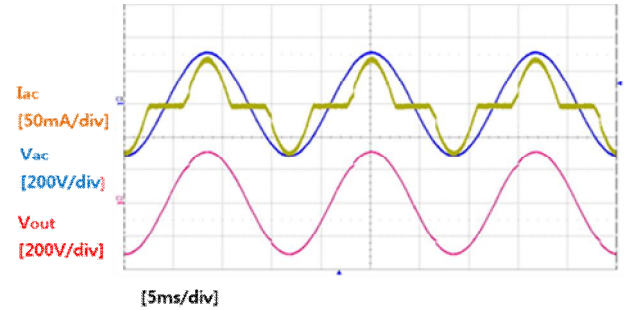

(b)

Fig. 4. Proposed phase-controlled dimmer. (a) Zero current conduction (minimum dimming). (b) Maximum dimming(99.9%).

4. Conclusion

The conventional phase-controlled dimmer, uses triac for lighting control, has several disadvantages caused by the characteristics of triac. In order to remove these disadvantages, the proposed phase-controlled dimmer uses MOSFET instead of triac. The MOSFET is free from latching & holding current and is voltage operated devices. Therefore, the overall dimming range is increased than conventional one.

Referring to the experimental results, proposed phase-controlled dimmer can expand the dimming range to 99.9%. It means that the dimming range of proposed dimmer is 28.92% wider than conventional one under the same load condition. Also, the proposed phase-controlled dimmer can pin to pin compatible with conventional one.

이 논문은 2013년도 중소기업 융복합 기술개발 사업으로 수행된 과제의 지원으로 연구되었음.

Reference

- [1] Yan-Cun Li, Chern-Lin Chen, "A Novel Primary-Side Regulation Scheme for Single-Stage High-Power-Factor AC-DC LED Driving Circuit", *Industrial Electronics, IEEE Transactions on*, Vol. 60, no. 11, pp. 4978-4986, Nov. 2013.
- [2] J. Smith, J. Speakes, and M. H. Rashid, "An overview of the modern light dimmer: design, operation, and application", *IEEE Power Symposium, Proceedings of the 37th Annual North American*, Oct. 2005, pp. 299-303.
- [3] H. Jiang, J. Lin, and S. Jin, "Light Emitting Diodes for High AC Voltage Operation and General Lighting", *U.S. Patent 6957899*, Oct. 25, 2005.