

# Characteristics of Time Varying Magnetic Fields in Thyristor Rectifiers of 19kA in Chlor-Alkali Industry

Siamak Shirmohammadi and Yongsug Suh

Department of Electrical Engineering, Smart Grid Research Center, Chonbuk National University

## ABSTRACT

This paper investigates the experimental and simulated time-varying magnetic field generation in a chlor-alkali manufacturing process. 19kA thyristor-based rectifier is modeled and analyzed. The performance is compared and evaluated on the basis of exposure guidelines from ICNIRP. The mechanical structure of current carrying conductor is simplified as an infinite long busbar model and low frequency harmonic contents up to 65kHz are considered. Thyristor rectifier generates a significant amount of low frequency magnetic field harmonic contents both at ac and dc busbar of rectifier infringing the limit of ICNIRP. Along with simulation analysis the experimental measurement of the time-varying magnetic field in ac input busbar, rectifier block, dc load and busbar are presented. The experimental test results partly confirm the simulation results.

## 1. INTRODUCTION

Human body is consistently exposed to electromagnetic fields surrounding electrical devices. Despite different opinions among the scientists, the public believe that the EMF (Electro Magnetic Field) resulting from electrical furnace, high voltage transmission lines, etc. can cause changes in cells. As a result of these general concerns, cooperation between health and environmental organizations, labor unions, and specialized agencies has been formed. Therefore, nearly four decades of research and study provided a scientific database of exposure limits for future development [1].

High current rectifiers have been used in industry for a long time. They supply the required electrical energy for melting, refining, and electrolyzing process. A high power rectifier characterizes itself as the source of relatively high current in the order of tens and hundreds of kA among many other industrial power conversion systems. Like other power electronic products, rectifiers use switching techniques to control the output waveform. As a result of switching high voltage and current, thyristor rectifier generates a significant amount of low frequency harmonic contents which generate considerable time-varying magnetic field in ac and dc side of rectifier. Some literatures listed other factors such as ripple and commutation as causes of EMF but obviously all of these are the secondary effects of switching [2,3]. Recently, the human exposure to time-varying magnetic field in high power rectifiers has been a growing concern. This high current generates a time-varying magnetic field of significant amplitude around the high current carrying conductor and the process load. Adverse biological effects of exposure to this strong magnetic field have been reported in previous literatures [4]-[6]. Considering the importance of limiting the human exposure to magnetic field in high power rectifiers, the optimal design and operation of high power rectifiers to mitigate time-varying magnetic field have been paid less attention to in previous literatures.

This paper investigates time varying magnetic field generation from a high power rectifier. In order to make this investigation more realistic and useful, a typical thyristor rectifier of 19kA for the electrolyzer in chlor-alkali industry is employed as the target system. Since magnetic field is directly related to the thyristor firing angle, reduction of firing angle is considered to be a reasonable solution to control the intensity of EMI (Electromagnetic Interference). However, small firing angle is not always possible due to output control range and transformer tap constraint. LC filter is an alternative solution to

mitigate the magnetic field in dc busbar and load [3]. This paper presents qualitative and quantitative analysis result about the relationship between the EMF generation and mitigation measures, e.g. firing angle and filter. Beside the simulation results which predict the volume of magnetic pollution, the investigation is conducted on experimental environment. Experimental evaluation of time-varying magnetic field is done in this paper. The evaluated time-varying magnetic field emitted from transformer's secondary side busbars, rectifier, and chlorine electrolysis process line are compared with ICNIRP (International Commission on Non-Ionizing Radiation Protection) guideline occupational exposure reference level.

## 2. SYSTEM CONFIGURATION

12-pulse thyristor rectifier (Fig.1) is one of the most economical, reliable and efficient solutions for high current low voltage applications [7]. The ac input block consists of twelve busbars connected between the secondary side of transformer and ac pole sides of 6-pulse thyristor rectifiers. It is noted that the positive and negative thyristor valve busbars are connected not in the mechanical enclosure of rectifier block but at the secondary side of transformer. This connection scheme improves the commutation property of thyristor rectifier [8]. The current flowing through this busbar to either positive or negative thyristor valve is unidirectional having relevant even-order harmonics. Therefore, the magnetic field generated by the current flowing through this ac input busbar gives a significant influence on the occupational exposure. The overall system specification along with the circuit parameters are summarized in TABLE I.

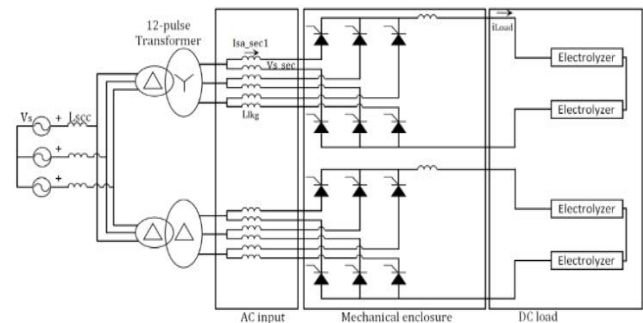

Fig 1 Schematic diagram of 18 6kA, 12 pulse high current rectifier

TABLE I. Overall System Input/Output Specification and Parameters

Specification	Symbol	Value
Medium Voltage AC Input	$V_s$	22.9 kV
Input Frequency	$f_{in}$	60 Hz
Transformer Leakage Inductance	$L_{lk}$	8% (pu)
Ac Input Power	$P_{in}$	16.1 MVA
DC Output Voltage	$v_{Load}$	695 V
DC Load Current	$i_{Load}$	18.6 kA
DC Output Power	$P_{out}$	12.9 MW
Transformer Secondary Voltage	$V_{s, sec}$	0.5 kV

## 3. ICNIRP GUIDELINES

Guidelines for limiting exposure to time-varying magnetic field have been established and ready to be put into effect by the ICNIRP [1]. The particular limit for time-varying magnetic field is provided in Fig. 2. Beside the reference levels, EMI factor plays a key index in assessing the role of harmonics in magnetic field. According to (1), EMI factor should be less than 1.

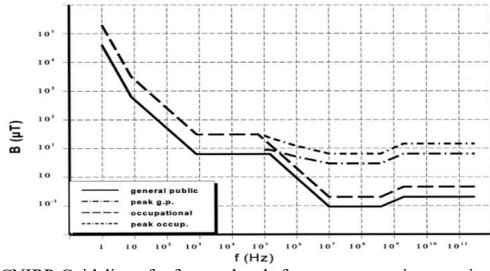

Fig 2 ICNIRP Guideline of reference levels for exposure to time varying magnetic fields

$$\sum_{j=1}^{65\text{kHz}} \frac{B_j}{B_{Lj}} + \sum_{j>65\text{kHz}} \frac{B_j}{b} \leq 1 \quad (1)$$

#### 4. SIMULATION RESULT OF TIME-VARYING MAGNETIC FIELDS

Occupational exposure to magnetic fields is analyzed in three blocks; ac input busbars, rectifier block in a mechanical enclosure, and dc load busbar. The rectifier block is usually contained in a mechanical enclosure made of metallic cabinet. Therefore, rectifier block is no concern. It is assumed that busbars both at the ac input and dc load block are quite long with respect to the field measurement point, therefore (2) can simply calculates the magnetic field.

$$B[\mu T] = 10^6 \times \mu_0 \times \frac{I}{2\pi r} \quad (2)$$

As mentioned before, because of the modeling constraint, the EMI factor is calculated up to the frequency of 65kHz. The simulation is performed with the distance (r) of 1 meter.

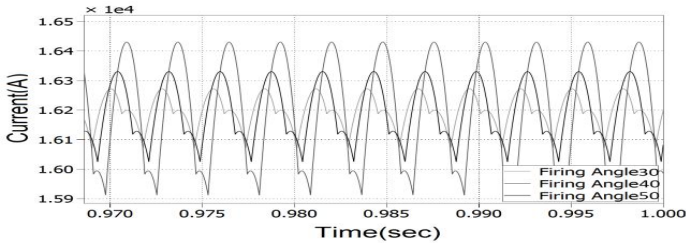

Fig 3 Waveform of dc load current (iLoad)

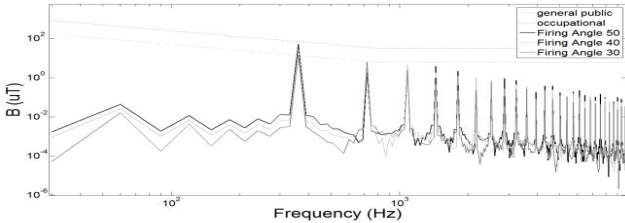

Fig 4 Frequency spectrum of magnetic flux density due to dc output (iLoad)

TABLE II. EMI factors under Various Firing Angle Conditions

Unit	Firing angle degree	Trans.Tap (Turn)	Secondary Voltage V	EMI Factor (ac input)	EMI Factor (dc load)	DC load current kA
Thyristor rectifier	50	28	730	48.5	1.40	16.2
	45	33	630	44.2	1.11	
	40	37	570	40.2	0.95	
	35	40.5	530	36.4	0.80	
	30	43	503	33.5	0.70	

The common practice to mitigate the harmonic contents is to employ passive filters at the dc output busbars [5]. The influence of filter size on the ripple and EMI factor of dc output current has been studied and presented in Figure 5 and TABLE III.

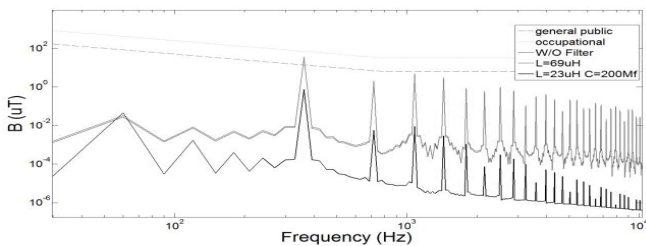

Figure 5 Frequency spectrum of DC load current (iLoad) with filters

TABLE III. EMI factors for thyristor rectifier under various filter conditions at DC side

Unit	Firing angle degree	Lf μH	Cf mF	EMI Factor (ac input side)	EMI Factor (dc load side)	DC load current kA		
Thyristor rectifier	45	0	0	44	1.11	25		
					1.05			
					1.005			
					0.961			
		23	67		133		200	0.007
								0.005
								0.004
								0.004

#### 5. EXPERIMENTAL RESULT OF TIME-VARYING MAGNETIC FIELDS

Measurement of time-varying magnetic field in the real plant environment has been carried out and presented in this paper. Similar to simulation condition, the time-varying magnetic field has been measured at the distance of 1 meter from the busbars.

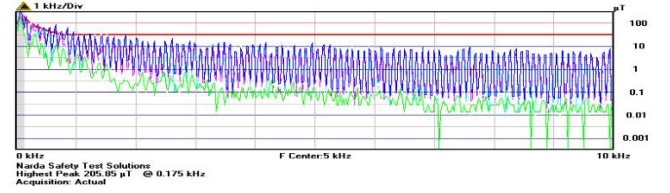

Figure 6 Measured Frequency spectrum of AC input busbars

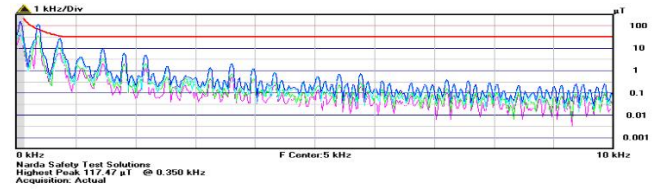

Figure 7 Measured Frequency spectrum of DC output busbars

#### 6. CONCLUSION

This paper investigates time-varying magnetic field generated from 19kA rectifier systems. In order to focus on the qualitative effect of rectifier operation upon the time-varying magnetic field generation, the mechanical structure of current carrying conductors in complete rectifier system is simplified. The performance of topology is compared and evaluated on the basis of previously reported guidelines for limiting exposure to time-varying magnetic field. Thyristor rectifier generates a significant amount of low frequency magnetic field harmonic contents both at ac and dc side of rectifier infringing the limit of ICNIRP. The experimental measurement accurately evaluated time-varying magnetic field at specific distance throughout the plant. Exceeding occupational exposure limit might increase the risk of adverse health effects. In order to stay below that limit, the LC filter is commonly used. EMI factor is an effective tool to obtain the optimal values of LC filter.

This work was supported by the National Research Foundation of Korea (NRF) grant funded by the Korea government (MSIP)(No 2010-0028509)

#### References

- [1] "ICNIRP guidelines for limiting exposure to time varying electric, magnetic and electromagnetic fields (up to 300 GHz)," Health Phys, 1998
- [2] Y Chenhu, Y Kai, L Xiuyan, W Wei, "Analysis and Prediction of EMI in Three-Phase Rectifier", *Control, Automation and Systems Engineering (CASE)*, 2011 International Conference
- [3] M Mazaheri, V Scaini, and W E Veerkamp, "Cause, effects and mitigation of ripple from rectifiers", *IEEE Industry Applications Society Petroleum and Chemical Industry Conference*, pp 85-91, 2002
- [4] A Hossam-Eldin, K Youssef and H Karawia, "Measurements and evaluation of adverse health effects of electromagnetic fields from low voltage equipments", 2008
- [5] R Takemoto, W J Ross Dunseth, JR, and W Joines, "Electromagnetic Fields Induced in Person Due to Devices Radiating in 10 Hz to 100 kHz Range," *IEEE Transactions On Electromagnetic Comaptibility*, vol 3, no 4, pp 529- 537, November 1988
- [6] D Kaklia, A Razmdze, G Ghvedashvili, L Shoshiashvili and R Zaridze, "Numerical study of human expose by em radiation", *Electromagnetic Compatibility and Electromagnetic Ecology, 2007 7th, international symposium*, pp 303-306 June 2007
- [7] T Siebert, A Troedson, and S Ebner, "AC to DC power conversion now and in the future", *IEEE Industry Applications Society Petroleum and Chemical Industry Conference*, pp 145-152, 2001
- [8] Y Suh and C Kim, "A Study on High-Current Rectifier Systems With Mitigated Time Varying Magnetic Field Generation at AC Input and DC Output Busbars," *Power Electronics, IEEE Transactions*, vol 27, no 3, pp 1212,1219, March 2012