

A New Method to Detect Inner/Outer Race Bearing Fault Using Discrete Wavelet Transform in Frequency-Domain

Amirhossein Ghods¹, Hong-Hee Lee²

^{1,2}Electrical and Computer Engineering Department, University of Ulsan
93 Daehak-ro, Mugeo-dong, Nam-gu, Ulsan, 680-749, KOREA

Abstract

Induction motors' faults detection is almost a popular topic among researchers. Monitoring the output of motors is a key factor in detecting these faults. (Short-time) Fourier, (continuous, discrete) wavelet, and extended Park vector transformations are among the methods for fault detection. One major deficiency of these methods is not being able to detect the severity of faults that carry low energy information, e.g. in ball bearing system failure, there is absolutely no way to detect the severity of fault using Fourier or wavelet transformations. In this paper, the authors have applied the Discrete Wavelet Transform (DWT) frequency-domain analysis to detect bearing faults in an induction motor. In other words, in discrete transform which the output signal is decomposed in several steps and frequency resolution increases considerably, the frequency-band analysis is performed and it will be verified that first of all, fault sidebands become more recognizable for detection in higher levels of decomposition, and secondly, the inner race bearing faults turn out easier in these levels; and all these matter because of eliminating the not-required high energy components in lower levels of decomposing.

1. Introduction

Fault prediction and detection of induction motors is nowadays a popular trend in the field of electrical machinery. Authors in [1-3] perform general surveys about fuzzy networks or artificial intelligence applications in vibration diagnosis. Or in [4], it is verified that most of mechanical and electrical faults occur in an induction motor have identical mathematical representation. The result of this research is used in the current paper to develop a model-based fault and detect it with the further-mentioned method.

In [5, 6], it can be seen that both continuous and discrete wavelet transformations are used for detection purposes. The main deficiency of these researches is that there is no definite measurement for fault's characteristics; in other words, the output of each wavelet transformation in case of fault occurrence is "just" compared with the healthy situation and if a major difference is monitored between situations, it would be concluded that fault "exists". By this method, first of all, realizing the type of fault and second of all, evaluating how much severity this fault has, is almost impossible.

For most of the faults, including bearing faults, impact vibration generated has relatively low energy; it is often overwhelmed by noise with higher energy and vibration generated from other microstructural components [7]. In this paper, a new approach for bearing fault detection has been proposed that relies on the frequency spectrum analysis of each decomposition level in discrete wavelet transform. The rest of article is structured as: in section II, with attention to the process of discrete wavelet transform, a SIMULINK model for fault simulation has been developed. Next, based on bearing mechanical characteristics in the rotor, the additional frequency sidebands in the case of fault

occurrence are derived and formulated. Finally, the frequency-domain analysis is performed on DWT decomposed levels and results are compared for situation that the bearing fault is caused either by inner race or outer race deficiency.

2. DWT Mathematical Representation for Induction Motor's Fault Modeling

The decomposition of the signal into different frequency bands is simply obtained by successive high pass and low pass filtering of the time domain signal. The original signal $x[n]$ is first passed through a half-band high pass filter $g[n]$ and a low pass filter $h[n]$. After the filtering, half of the samples can be eliminated according to the Nyquist probability rule, since the signal now has a highest frequency of $f/2$ radians instead of f . The signal can therefore be subsampled by 2, simply by discarding every other sample. This constitutes one level of decomposition and can mathematically be seen in Fig.1 and expressed as follows:

$$y_{high}[k] = \sum_n x[n].g[2k - n] \quad (1)$$

$$y_{low}[k] = \sum_n x[n].h[2k - n] \quad (2)$$

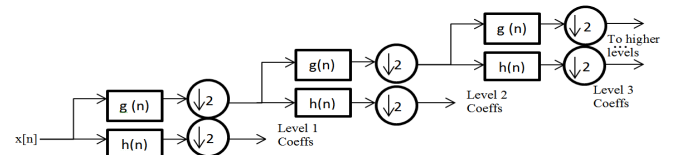

Fig. 1 DWT decomposition process

This decomposition halves the time resolution since only half the number of samples now characterizes the entire signal. However, this operation doubles the frequency resolution, since the frequency band of the signal now spans only half the previous frequency band, effectively reducing the uncertainty in the frequency by half. Reduction of uncertainty in the signal will help to induce more exact information out of signal and that is the key point in DWT.

Following, a SIMULINK model in Fig. 2 for induction motor is developed for fault implementation.

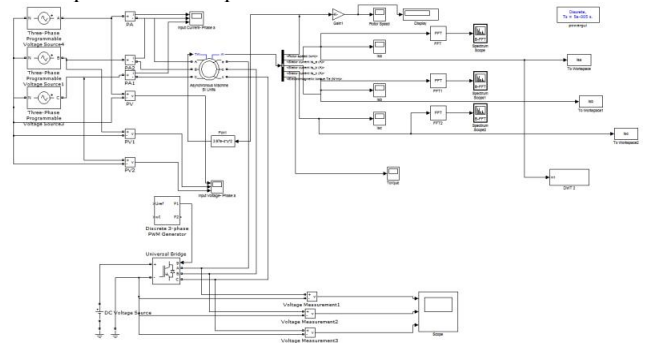

Fig. 2 Induction motor fault detection SIMULINK model

The type of induction motor is squirrel cage with nominal speed of 1430 rpm of power of 4 kW, on a 400 V, 50 Hz feeder

3. Bearing Fault Diagnosis

The frequencies that side bands are created in case of fault happening can be classified as: ball pass frequency at outer race f_o , and ball pass frequency at inner race f_i [13].

$$f_o = \frac{n}{2} f_r \left[1 - \frac{BD}{PD} \cos(\beta) \right] \quad (3)$$

$$f_i = \frac{n}{2} f_r \left[1 + \frac{BD}{PD} \cos(\beta) \right] \quad (4)$$

Where, n is the number of balls, PD is the bearing pitch diameter, BD is the ball diameter, β is the contact angle of the balls on the races as shown in Fig. 3, and f_r is the rotor rotational speed in Hz.

The characteristic frequencies given above may be approximated for normal bearings with 6 to 12 balls by:

$$f_o = 0.4nfr \quad (5)$$

$$f_i = 0.6nfr \quad (6)$$

So, for the case study, with attention to the nominal frequency that is 50 Hz, the side-bands around this frequency in case of bearing fault will be appear in:

$$f_o = 0.4 \times 6 \times 50 = 120 \text{ Hz}$$

$$f_i = 0.6 \times 6 \times 50 = 180 \text{ Hz}$$

A common way of modeling localized bearing faults is applying sequence of high frequency bursts, which represent the impulse response of the signal transmission path, and can be repeated at a rate related to the fault that is interacting with whether inner race, outer race, or rolling elements [8]. Therefore, by applying these high frequency bursts, bearing fault will be realized.

4. Simulation

As it has been clarified before, the signal is a 128-sample long derived on 4 kHz sampling frequency. Therefore, 7 levels of decomposition will be performed up to the time that only 2 samples are remained.

By applying the bearing fault at $t=1$ sec, with the use of high frequency bursts sequences, and what happens consequently in Fig. 7 (stator currents), the bearing fault frequency side-bands cannot be recognized in low levels of decomposition, due to low energy of bearing fault signals [7]. Therefore, there is need to decompose the stator current signal in higher levels in frequency domain. By this action, due to Nyquist probability theorem, not-required high energy components are withdrawn and only vital information is remained

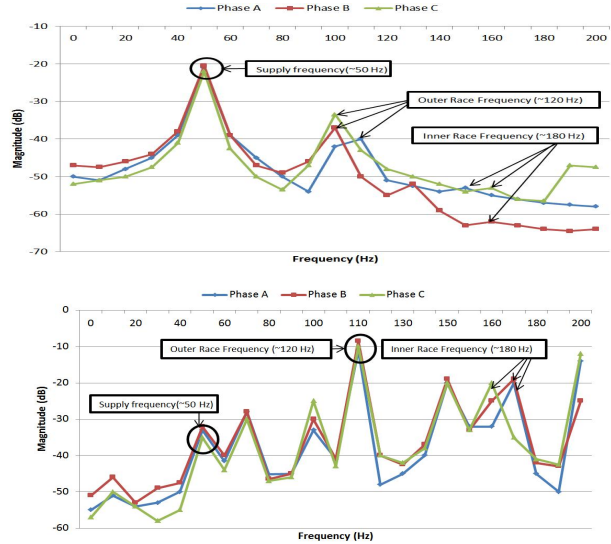
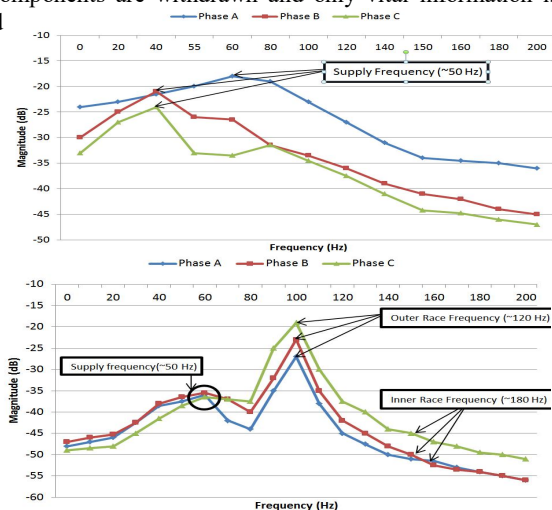

Fig. 7. Faulty motor DWT frequency decomposition levels; (a) Level 1, (b) Level 3, (c) Level 5, (d) Level 7

As it can be seen, inner race failure is more visible when the frequency resolution increases in higher levels of decomposition.

5. Conclusion

In this paper, a new method for diagnosis of faults in induction motor has been proposed, which relies on Discrete Wavelet Transform (DWT). On the other hand, such faults as bearing system failures that carry low energy information can be diagnosed by decomposition using DWT. It has been shown the especially inner race defect can be recognized earlier when the high energy additional noises are reduced.

Acknowledgment

This work was partly supported by the National Research Foundation of Korea Grant funded by the Korean Government (No.2013R1A2A2A01016398) and the Network-based Automation Research Centre (NARC) funded by the Ministry of Trade, Industry & Energy.

References

- [1] G. K. Singh et al., "Induction machine drive condition monitoring and diagnostic research-a survey," *Elect. Power Sys. Research*, vol. 64, no.1, pp. 145-158, 2005.
- [2] Y. Zhongmig and W. Bin, "A review on induction motor online fault diagnosis," in *Proc. Power Electronics and Motion Control Conf.*, Beijing, Aug. 2000, pp. 1353-1358.
- [3] E. Wiedenbrug et al., "Modern on-line testing of induction motors for predictive maintenance and monitoring," in *Pulp and Paper Industry Technical Conf.*, Portland, OR, Jun. 2001, pp. 163-168.
- [4] R. Isermann, "Supervision, fault-detection and fault-diagnosis methods-an introduction," *Control Eng. Practice*, vol. 5, no. 5, pp. 639-652, 1997.
- [5] E. Ayaz et al., "Fault detection based on continuous wavelet transform and sensor fusion in electric motors," *Computation and Math. in Elec. Eng.*, vol. 28, no. 2, pp. 454-470, 2009.
- [6] A. O. Moreno et al., "Automatic online diagnosis algorithm for broken-bar detection on induction motors based on discrete wavelet transform for FPGA implementation," *IEEE Trans. Ind. Electron.*, vol. 55, no. 5, pp.2193-2203, 2008.
- [7] J. Zarei and J. Poshtan, "Bearing fault detection using wavelet packet transform of induction motor stator current," *Tribology Int.*, vol. 40, no. 1, pp. 763-769, 2007.
- [8] P. D. McFadden and J. D. Smith, "Vibration monitoring of rolling element bearings by the high frequency resonance technique, a review," *Tribology Int.*, vol. 11, no. 1, pp. 3-10, 1984.