

A Study of Grid-Connected PV System with Power Control Structure

Trung-Kien Vu, Youngsang Bae and Seongjin Oh

R&D Center, KACO new energy Inc. (trungkien.vu@kaco-newenergy.kr)

146-8 Sangdaewon-dong, Jungwon-gu, Seongnam-si, Gyeonggi-do, KOREA (462-807)

Abstract

The rising popularity of renewable energy sources resulted in development of the units of higher rated powers, where the large-scale plants and grid-connected type solar power systems are increased. Therefore, the importance of grid stabilization, which depends on each country or system-type, has been strengthened by different grid-codes or certifications. In this paper, the control scheme of three-phase photovoltaic system is enhanced, where both injected active and reactive powers are simultaneously controlled with the consideration of the certification of the Germany Association of Energy and Water Industries (BDEW). Experimental results are shown to verify the theoretical analysis.

1. Introduction

Generally, a PV system is categorized into the stand-alone and grid-connected type. In the global market, a large proportion of PV solar power is supplied by the grid-connected type. The conventional current control of grid-connected PV system is to supply the maximum available active power from the PV array to the grid. However, if the grid voltage and its frequency are varied, the amount of consumed power is relatively changed. For example, the grid frequency depends on the supplying-speed of the supply power. Hence, the active power is controlled for grid frequency variation based on the Germany Association of Energy and Water Industries (BDEW) certification. Furthermore, the conventional current control scheme cannot remain the desired power to the grid in case of grid voltage variations (maximum $\pm 10\%$) or independently control the output active power. To solve this problem, the grid-connected PV system should not only supply active power to the system via the maximum power point tracking (MPPT), but also the reactive power and improve the power quality with power control technique, due to the strict standard and grid code requirements [1]-[4].

This paper is focused on the active/reactive power control scheme for a three-phase grid-connected PV system with the use of instantaneous power theory. The power control part is integrated with the conventional synchronous current control scheme, where the certification of BDEW is taken into account. The proposed control method not only can compensate the reactive power demanded by a dip grid but also perform the power quality control (PQC). The experimental results are shown to verify the effectiveness of proposed control scheme.

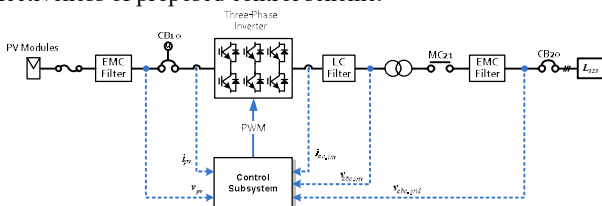

Fig.1 Configuration of three-inverter system

2. Power Control Scheme for Grid-Connected Voltage Source Converter (VSC)

According to [5], active and reactive powers can be calculated using the voltage and current in the qd form as follows:

$$p = \frac{3}{2}(v_q i_q + v_d i_d) = \frac{3}{2} \begin{bmatrix} v_{qd} \end{bmatrix}^T \begin{bmatrix} 1 & 0 \\ 0 & 1 \end{bmatrix} i_{qd} \quad (1)$$

$$q = \frac{3}{2}(v_q i_d - v_d i_q) = \frac{3}{2} \begin{bmatrix} v_{qd} \end{bmatrix}^T \begin{bmatrix} 0 & 1 \\ -1 & 0 \end{bmatrix} i_{qd}$$

Assuming v_d to be zero, which can be ensured by an adequate tracking of the grid voltage measure using a PLL, (1) implies that active/reactive powers are proportional to i_q and i_d , respectively.

2.1 Active Power Control

Fig. 2 shows the overall control structure, where the current reference signals are generated by power control part. As shown in Fig. 2, the active/reactive powers of the grid-side should be continuously measured using (1), and instantaneously separated into their average and oscillating parts. In the real implementation, this separation is realized through a low-pass filter. The cut-off frequency of low-pass filter must be selected carefully as to inherent dynamics that lead to compensation errors during transients. Unfortunately, the unavoidable time delay introduced by the low-pass filter may degenerate the entire performance of the system during transient.

A dc voltage regulator should be added to the control strategy in a real implementation. In fact, a small amount of average real power (P_{loss}) must be drawn continuously from the power system to supply switching and losses in the PWM converter. Otherwise, this energy would be supplied by the dc capacitor, which would discharge continuously. This means that the dc voltage must be kept higher than the peak value of the ac-bus voltage, in order to guarantee the controllability of the PWM current control.

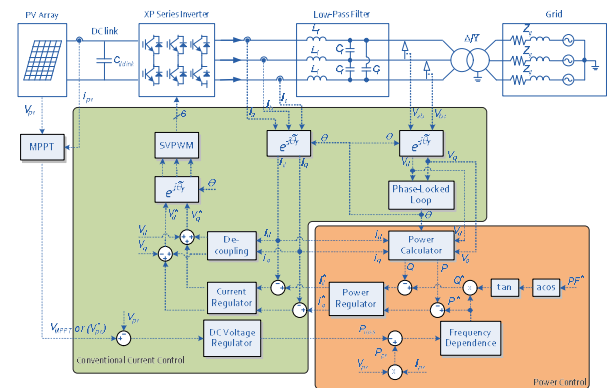

Fig 2 Power control scheme

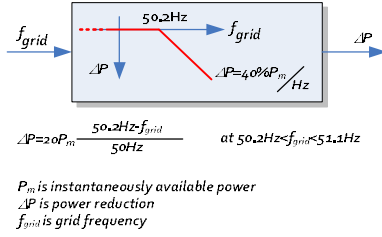

Fig.3 Active power reduction in case of over frequency

Table 1. System parameters

Rated power	100[kW]
Grid voltage	380[V]
MV transformer	380[V]/20[kV]
LC-filter inductance	65[μH]
LC-filter capacitance	200[μF]
Switching frequency	3[kHz]
Grid frequency	60[Hz]

All renewable-based generating units must reduce its instantaneous active power with a gradient of 40% of the generator’s instantaneously available capacity per Hertz while in operation, at a frequency of more than 50.2 Hz. If the frequency returns to a value of $f \leq 50.05\text{Hz}$, the active power output may be increased again as long as the actual frequency does not exceed 50.2Hz. This control is realized in a decentralized manner (at each individual generator). The neutral zone must be below 10mHz [2].

2.2 Reactive Power Control

In case of using 2nd-order or 3rd-order output low-pass filter, the reactive components in filter capacitors shown in (2), must be considered in the control design.

$$q_c = 3i_c v_c = 3(v_c / z_c) v_c = 3\omega C v_c^2 \quad (2)$$

where ω is the grid frequency (rad/s), C and v_c are the filter capacitance and voltage, respectively.

The reactive power set point can be either fixed or adjustable by a signal from operators. The set point value is either

- A fixed reactive power value in MVar or
- A fixed PF or
- A variable reactive power depending on the voltage Q(V) or
- A variable PF depending on the active power [4].

Based on the fact that the reactive power can be consider as a function of power factor, hence, the reactive power reference can be chosen as follows:

$$q^* = p^* \tan \left[a \cos \left(PF^* \right) \right] \quad (3)$$

where “*” denotes the reference values. The PF is adjusted within the appropriate range (-0.95 to 0.95 depends on the inductive (lagging) or capacitive (leading) cases).

Hence, the reactive power control can be considered as a closed-loop control so far, where both reactive power and PF can be controlled.

3. Results

The system parameters are listed in Table 1. Fig. 4(a) show the output power responses in case of current control when voltage dips, where that of power control case is shown in Fig. 4(b). As shown, the power control can remain an approximately rated power at 10% dip voltage. Fig. 5 shows the reactive power control via PF changing.

The experimental results show a good performance of proposed control structure.

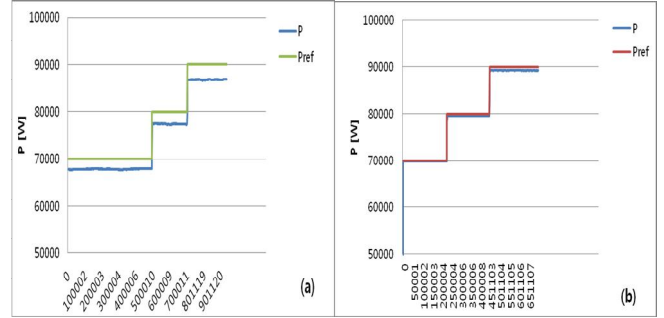

Fig.4 70%~90% of active power and its reference in case of (a) current control and (b) power control when 10% dip of grid voltage

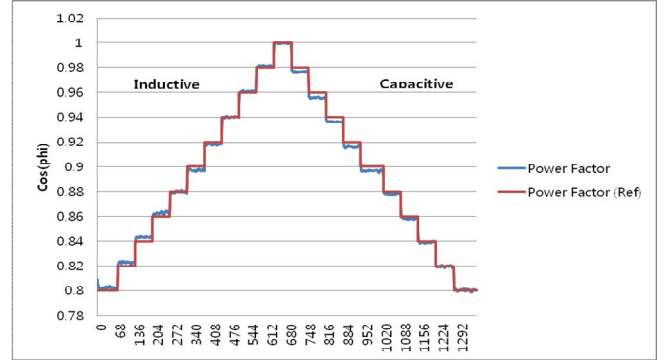

Fig.5 Reactive power control with PF changing

4. Conclusion

This paper was focused on the enhancement of control scheme for three-phase high power PV inverter systems using power control technique. Both injected active/reactive powers are simultaneously controlled with the consideration of the certification of the Germany Association of Energy and Water Industries (BDEW). Experimental results are shown to verify the effectiveness of the proposed control approach.

References

- [1] -, “IEEE Recommended Practices and Requirements for Harmonic Control in Electrical Power Systems”, IEEE Std 519-1992, 1993
- [2] Holger Berndt et al., “Network and System Rules of the German Transmission System Operators”, Transmission Code, 2007.
- [3] Wolfgang Bartels et al., “Generating Plants Connected to the Medium-Voltage Network”, Technical Guideline of BDEW, 2008.
- [4] E. Troester, “New German Grid Codes for connecting PV systems to the medium voltage power grid”, 2nd International Workshop on Concentrating Photovoltaic Power Plants: optical Design, Production, Grid Connection, pp.1-4, 2009.
- [5] H. Akagi, E. H. Watanabe and M. Aredes, *Instantaneous Power Theory and Applications to Power Conditioning (IEEE Press Series on Power Engineering)*, Hoboken, NJ: Wiley-IEEE Press, 2007.
- [6] L.Hassaine, E. Olias, J. Quintero and M. Haddadi, “Digital power factor control and reactive power regulation for grid-connected photovoltaic inverter”, *Renewable Energy*, Vol. 34, pp. 315-321, 2009.
- [7] Fabio L. Albuquerque, Adelio J. Moraes, Geraldo C. Guimaraes, Sergio M.R. Sanhueza and Alexandre R.Vaz, “Photovoltaic solar system connected to the electric power grid operating as active power generator and reactive power compensator”, *Solar Energy*, Vol. 84, pp. 1310-1317, 2010.