

An Effective Control Scheme for Battery Charger System in Electric Vehicles

Cong-Long Nguyen*, Hong-Hee Lee**

School of Electrical Engineering, University of Ulsan
93, Daehak-ro, Nam-gu, Ulsan 680-749, KOREA

Abstract

This paper presents an effective control scheme for an electric vehicle battery charger where a symmetrical bridgeless power factor-corrected converter and a buck converter are cascaded. Both converters have been popular in industries because of their high efficiency, low cost, and compact size, hence combining these converters makes the overall battery charging system strongly efficient. Moreover, this charger topology can operate at universal input voltage and attain a desired battery current and voltage without ripple. In order to achieve a unity input power factor and zero input current harmonic distortion, the proposed control scheme adopts duty ratio feed-forward control technique in both current and voltage control loop. Additionally, in the current loop, its reference is created by a phase-locked loop (PLL) block, leading to a pure sinusoidal input current although the input voltage waveform is being distorted. The feasibility and practical value of the proposed approach are verified by simulation and experiment with an 110V/60Hz ac line input and 1.5kW-72V dc output of the battery charging system.

1. Introduction

In electric vehicles (EVs), power electronics including power conversion unit, traction motor part, and battery charger module play a critical role to decide whether the EVs are popular in the market [1]. The biggest limitation of the EVs is located in energy storage device, i.e. the battery. Factors such as short driving range, long charging time, and high initial cost confine battery-powered vehicles to only small vehicular applications [2]. To overcome this restriction, new concept of EVs named Plug-in Hybrid Electric Vehicles (PHEVs) is introduced. In PHEVs, the battery can be charged from a grid at home or at charging station so that the vehicles are able to increase their driving range.

Generally, the battery charger comprises of two converters that are connected in serial. The first converter is a front-end Power Factor-corrected Converter (PFC), which is used to control input Power Factor (PF) at unity, to regulate the ac current being a pure sinusoidal waveform, and to keep its dc output voltage stable. Meanwhile, the second converter is a dc-dc converter that is adopted to manage the battery charging current and charging voltage without any ripples regardless of its input dc voltage variation [3].

In this paper, an effective control scheme is proposed to control a battery charging system where a symmetrical bridgeless power factor-corrected converter (SBPFC) and a buck converter are cascaded. In order to achieve a unity input power factor and zero input current harmonic distortion for the battery charging system, the proposed control scheme adopts duty ratio feed-forward control technique in both current and voltage control loop. Moreover, in the current loop, its reference is created by a Phase-Locked Loop (PLL) block in order to obtain a pure sinusoidal

input current although the input voltage waveform is distorted. The feasibility and practical value of the proposed approach are verified by simulation and experiment with an 110V/60Hz ac line input and 1.5kW-72V dc output.

2. Description of the proposed control scheme

2.1 The charger topology

Fig. 1 shows the configuration of the proposed battery charger, which contains the SBPFC as a front-end PFC converter and the buck converter as a back-end converter. From the point of view of input and output voltage waveform, the charger is an ac-dc converter that converts ac voltage of the grid to dc voltage for the battery. To utilize the grid at a maximum active power, a unity input power factor of the battery charger must be achieved, so that the front-end PFC converter is required. Under unity input power factor condition, the grid current becomes in phase with the grid voltage and, hence, the dc output voltage of the front-end PFC oscillates twice of the grid frequency because of an imbalanced power between the alternating input power and dc output power. When this voltage ripple is too high to apply to the battery, the second stage dc-dc converter is necessary for safe operation of the battery.

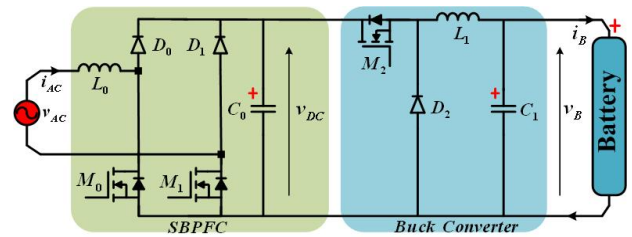

Fig. 1 The proposed battery charger.

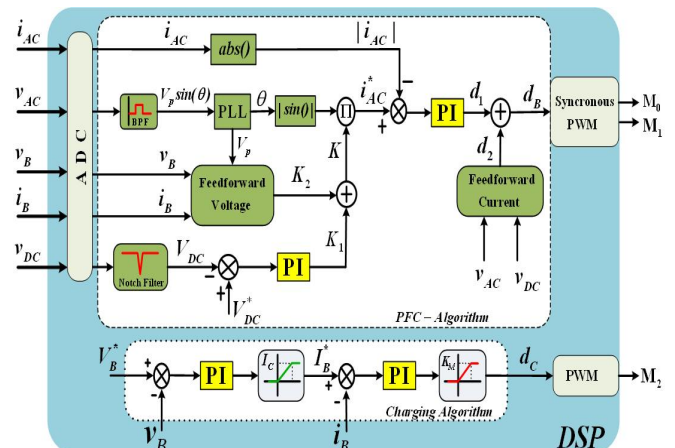

Fig. 2 The proposed control scheme for the battery charger.

2.2 The control scheme

The proposed control scheme is shown in Fig. 2, which consists of a PFC control algorithm and a charging strategy. In general, the PFC control algorithm includes two controllers. The first is a voltage controller with PI compensator to regulate the dc output voltage of the SBPFC. The second is a current controller with PI compensator to adjust the grid current to achieve the unity input power factor. In order to minimize current harmonic injecting to the grid, the reference of current controller is constituted by multiplying the output of voltage controller with an output of a single-phase PLL technique [4], which combines a second band pass filter (BPF) to detect the phase of the fundamental grid voltage component. In addition, to lessen burden of the PI compensators and to improve dynamic response of both current and voltage controller, feed-forward parts are added. Using the power conservation law and basing on the principal operation of the SBPFC, the feed-forward voltage and current are given respectively as following:

$$K = 2v_B i_B / V_p \quad (1)$$

$$d(t) = 1 - |v_{AC} / v_{DC}| \quad (2)$$

where v_B and i_B are battery voltage and battery charging current, K and V_p are the peak of grid voltage and grid current, respectively.

Next, the charging control algorithm is made up by cascading two PI compensators with current saturation at a rated charging current I_C and a duty-cycle saturation block to obtain a constant-current constant-voltage (CC-CV) charging method.

3. Experimental results

In order to verify the effectiveness of the proposed control scheme, the battery charging system is setup to charge a 72V-50Ah seal lead-acid battery pack from an 110V/60Hz ac grid. To develop the 1.5kW battery charging system, MOSTFET IRFP460 and fast recovery diode RURG8060 are used for the switches M_0 , M_1 , M_2 , and the diodes D_0 , D_1 , D_2 . In addition, 1.05mH inductances and 840 μ F capacitances are employed for inductors L_0 , L_1 and capacitors C_0 , C_1 , respectively. Furthermore, the system is implemented in laboratory with a high performance DSP (TMS320F28335 by Texas Instrument) and all switches are turned on and off at 40 KHz.

Fig. 3 shows performance of the system during charging the battery with 12A. It is easy to recognize that the grid voltage and current have no phase displacement, which leads to the unity input power factor. In addition, the grid current is a pure sinusoidal signal that prevents the charger polluting the grid. Furthermore, both charging current and battery voltage contain no ripple and it is another benefit of the proposed control scheme.

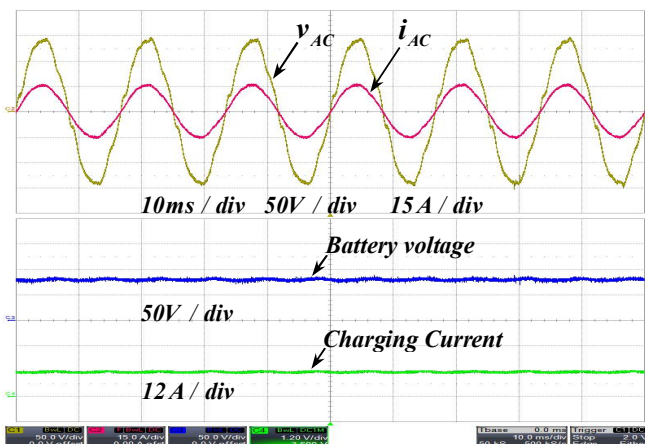

Fig. 3 The battery charging performance at steady state time.

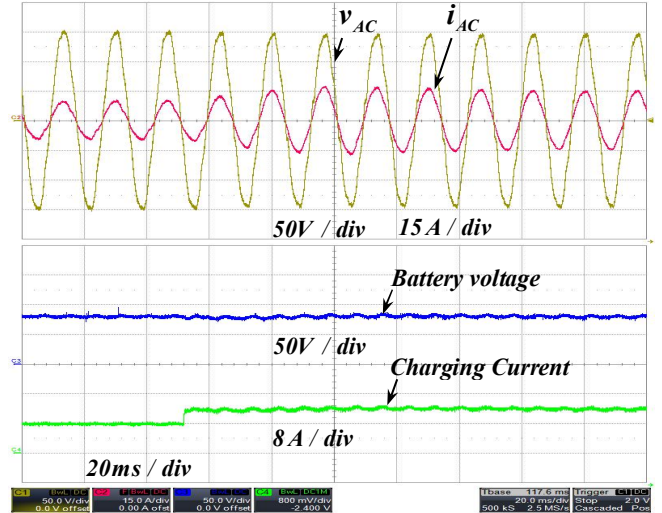

Fig. 4 Testing dynamic response of the system.

In order to test dynamic response of the proposed control scheme, the charging current command is changed from 8A to 12A, and the experimental results are shown in Fig. 4: The grid current keeps a pure sinusoidal waveform and a unity input power factor even though the load current is changed and the charging current tracks its reference simultaneously without any ripple in the battery voltage.

4. Conclusion

In this paper, we proposes an effective control scheme for a universal input battery charger where two efficient converters including a symmetrical bridgeless power factor-corrected converter and a buck converter are cascaded. The proposed charger system achieves good performances such as a unity input power factor, zero harmonic current injecting to the grid, and no ripple in both the battery current and the battery voltage. Furthermore, dynamic response of the control strategy is successfully evaluated by changing the charging current command. Simulation and experimental results are given to prove the effectiveness of the proposed control scheme.

Acknowledgment

This work was partly supported by the NRF grant funded by the Korea government (MEST) (No. 2010-0025483) and the Network-based Automation Research Center (NARC) funded by the Ministry of Knowledge Economy.

References

- [1] A. Emadi, Y.J. Lee, K. Rajashekara, "Power Electronics and Motor Drives in Electric, Hybrid Electric, and Plug-In Hybrid Electric Vehicles," IEEE Trans. Ind. Electron., vol. 55, no. 6, pp. 2237-2245, Jun. 2008.
- [2] A.K. Yadav, P. Gaur, A.K. Jha, J.R.P. Gupta, A.P. Mittal, "Optimal Speed Control of Hybrid Electric Vehicles," Journal of Power Electronic, vol. 11, No. 4, pp. 393-400, July 2011.
- [3] Y.B. Bilgin, E. Dal Santo, M. Krishnamurthy, "Universal Input Battery Charger Circuit for PHEV Applications with Simplified Controller," Applied Power Electronics Conference and Exposition (APEC) 2011, pp. 815-820, March 2011.
- [4] K.Y. Kim, S.H. Park, S.K. Lee, T.K. Lee, C.H. Won, "Battery charging system for PHEV and EV using single phase AC/DC PWM buck converter," Vehicle Power and Propulsion Conference (VPPC) 2010, pp.1 -6, Sept 2010.