

## Crowbar 운전을 가지는 이중여자자유도발전기 풍력발전시스템의 제어전략

저스토 잭슨 존\*, 노경수  
 동국대학교 전자전기공학부

### Control Strategies of Doubly Fed Induction Generator -Based Wind Turbines with Crowbar Activation

Jackson John Justo\*, Kyoung-Soo Ro

Division of Electronics and Electrical Engineering, Dongguk University

**Abstract** - The insertion of the crowbar system in the doubly fed induction generator rotor circuit for a short period of time during grid disturbance enables a more efficient way of limiting transient rotor current and hence protecting the rotor side converter (RSC) and the DC-link capacitor. When crowbar is activated at fault occurrence and clearance time, RSC is blocked while DC-link capacitor and the grid side converter (GSC) can be controlled to provide reactive power support at the PCC and improve the voltage which helps to comply with grid codes. In this paper, control strategies for crowbar system to limit the rotor current during fault is presented with RSC and GSC controllers are modified to control PCC voltage during disturbance to enhance DFIG wind farm to comply with some strict grid codes. Model simulated on MATLAB/Simulink verify the study through simulation results presented.

#### 1. Introduction

Grid code requirements have been a major driving factor for the wind turbines development nowadays, and recently relevant publications are already available. In [1], a review for the connection requirements for wind turbines to the grid network in various countries are provided.

While the recent development in modern power electronics technology, the attention is being directed on variable-speed wind turbine (VSWT) equipped with the doubly fed induction generator (DFIG) are more suitable for high-capacity wind farms. VSWT-DFIG offer several advantages compared to the fixed speed generators. These advantages including speed control, reduced flicker and four quadrant active and reactive powers control capabilities. Also, the VSWT-DFIG based wind turbine, the induction generator is connected to the grid via the stator; and the rotor is connected to the grid via a partially rated variable frequency AC/DC/AC converter (VFC), which can only handle a fraction (25% - 30%) of the total power to achieve full control of the generator, hence this configuration leads to higher energy yield compared to other type of configurations [2].

However, VSWT-DFIG has some demerits during grid faults. Some undesirable high stator currents may be produced which are also induced in the rotor windings due to electromagnetic coupling of the double fed generator, [3]. The induced transient rotor current result in high rotor voltage which may damage the rotor winding insulating materials, the RSC due to high rotor current and the dc-link capacitor due to high ripple dc-voltage across the DC-link.

This paper presents the study about crowbar protection circuit and the desired change in control system when DFIG operates under transients condition with crowbar activated. This study carried under sub-synchronous and super-synchronous speed operations and simulations results considered for fault with short and long duration.

#### 2. Modeling and Control of DFIG Based Wind Turbines

Modeling of VSWT-DFIG for steady state and transients studies have been presented many researchers. In [3], the influence each part simplification towards stability analysis has been discussed and model for each part being presented. detail about modeling of wind turbine is also given in [4].

#### 2.1 Control of DFIG During Normal Operation

The DFIG and its performance in normal operation have been discussed in a variety of publications [2],[3]. The RSC controller independently regulates the stator active (torque) and reactive power transferred to the PCC. The GSC is normally controlled to transfer power from/to rotor to/from grid keeping the DC Link voltage constant regardless of the magnitude and direction of rotor power. In the synchronous reference frame fixed to the stator flux, the relationship between the rotor current components and the stator active (controlled by q-axis rotor current component) and reactive powers (controlled by d-axis rotor current component) can be shown below. Under normal conditions, reactive power references in both cases is set  $Q_s^* = Q_{gsc}^* = 0$  if unity power factor is preferred.

$$P_s = \frac{3}{2} \omega_s \frac{L_m^2}{L_s} i_{mo} i_{qr} \quad (1)$$

$$Q_s = \frac{3}{2} \omega_s \frac{L_m^2}{L_s} (i_{dr} - i_{no}) i_{mo} \quad (2)$$

#### 2.2 Control of Rotor Side Converter (RSC)

The RSC controller has two objectives during normal operations: 1) Independently regulates the stator active (torque) through the quadrature - axis rotor current; and 2) Regulates the reactive power being transferred to the PCC from the stator using direct - axis rotor current components.

The controller is designed based on PI-control and Fig. 1 (a) and (b) below show the RSC controller with the reference stator power obtained from MPPT - curve, while reactive power reference is set zero.

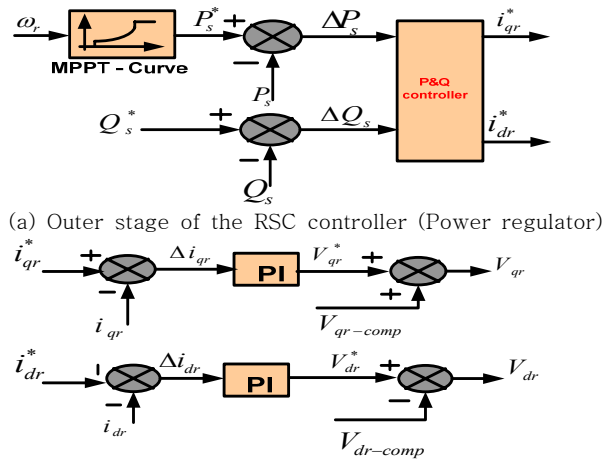

(b) Inner stage of RSC controller (Current regulator)  
**<Fig. 1> Block diagrams for the RSC controller**

#### 2.3 Control of Grid Side Converter (GSC)

The GSC control loop normally have two objectives 1) It keeps the dc-link constant hence regulates the power from rotor to grid and vice-versa through the q-axis loop; and 2) It regulates the DFIG - GSC reactive power using d-axis current component depending on the desired value regardless of the magnitude and direction of rotor power. The controller is designed based on PI-conventional

controller and Fig. 2 (a) - (b) show the block diagram for GSC in synchronous reference.

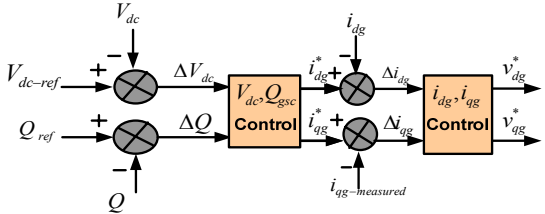

(a) Outer and inner stages of GSC controller

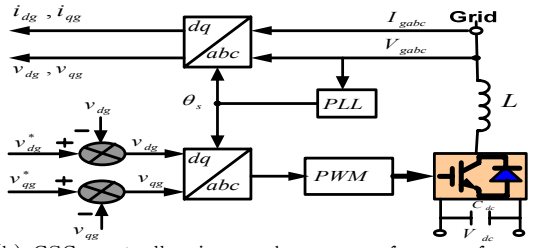

(b) GSC controller in synchronous reference frame.  
**<Fig. 2> GSC controller block diagram**

### 2.4 DFIG During Transient Operation

When the stator voltage reduces to low values, high stator and rotor currents flow, also large DC Link overvoltage are produced. [6]. Converter ratings cannot produce the required voltage to control the generator. To eliminate the high current in the rotor, crowbar is applied which its activation depends on level of rotor current magnitude or the dc link voltage. Figure 1.0 below shows the simulations results when crowbar is applied during 3-phase short circuit fault.

The rotor transient current during fault without crowbar is 4.2p.u, when crowbar is applied, the current is reduced to 2.0p.u. While the DC link voltage before crowbar is 1900V and with crowbar the DC link voltage is reduced to 1350V as shown in Fig. 3 (a) and (b) above.

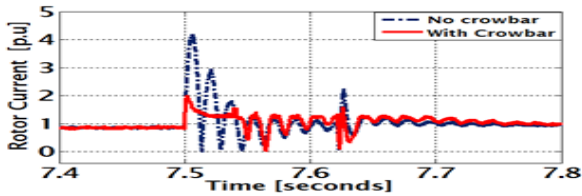

(a) Rotor current magnitude with and without crowbar

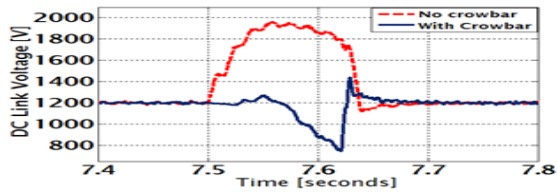

(b) DC Link voltage response

**<Fig. 3> Simulation results for the crowbar activation period**

### 2.5 Terminal Voltage Control

During grid disturbance, crowbar is activated for short time and RSC is disconnected and re-connected depending on the disturbance duration. The RSC and GSC controller objectives can be changed for long duration fault to support PCC voltage while the crowbar is deactivated and the fault not cleared. In this case,  $Q_{gsc}^* = i_{qg}^* \neq 0$ , instead the value is obtained from PCC voltage.

Simulation results are shown in Fig. 5 (a) and (b) shows that there is an improvement in PCC voltage when the modified controller in Fig. 4 is applied. These improvement in PCC voltage helps the DFIG to comply with strict grid codes. The modified controller is suitable for sub-synchronous and super-synchronous speed of

operating.

### 3. Conclusion

A 15 [MW] DFIG wind farm under transient state was simulated during sub-synchronous and super-synchronous speed. Simulation results show that crowbar protection reduced the transient rotor current and the dc link voltage to a safe value, however the crowbar optimal resistance for both sub/super-synchronous speed operations gave the similar response. During grid disturbance, crowbar is activated for a short time and deactivated while the disturbance was not cleared, in this case RSC the GSC can be controlled to improve the PCC voltage. From the simulation result (depicted in Fig 5), the modified controller improved the PCC voltage to comply with Germany and Spanish Grid Codes (the most strict GCs). The same response were obtained for short (150ms) and long (500ms) duration grid disturbances.

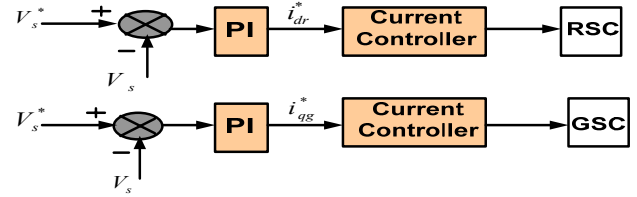

**<Fig. 4> Modified terminal voltage control both RSC and GSC**

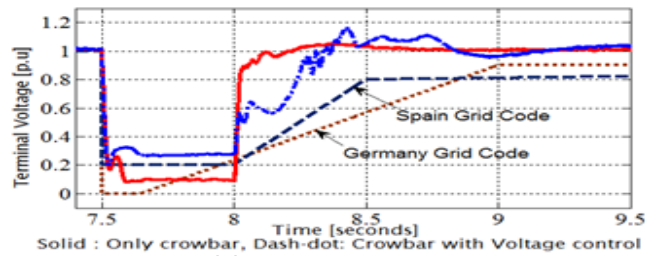

**<Fig. 5> (a) Terminal voltage during super-synchronous speed (15m/s)**

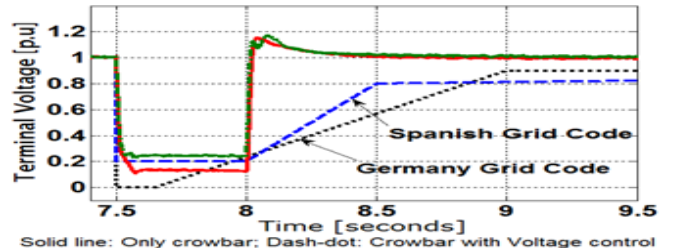

**<Fig. 5> (b) Terminal voltage during super-synchronous speed (7.5m/s)**

### References

- [1]. M. Tsili and S. Papathanassiou. "A review of grid code technical requirements for wind farms". IET Renew. Power Gener., 2009, Vol. 3, Iss. 3, pp. 308 - 332.
- [2]. L. Holdsworth, X.G. Wu, J.B. Ekanayake and N. Jenkins. "Comparison of fixed speed and doubly-fed induction wind turbines during power system disturbances". IEE Proc - Gener. Trans. Distr. Vol. 150, No. 3, May 2003.
- [3]. Mustafa Kayikci and J.V. Milanovic. Assessing Transient Response of DFIG-Bsed Wind Plants-The Influence of Model Simplifications and Parameters. IEEE Transactions on Power Systems, Vol. 23, No. 2, May 2008.
- [4]. Johan Morren and Sjoerd W. H. de Haan. "Short circuit current of wind turbines with Doubly Fed Induction Generator". IEEE Transactions on Energy Conversion, Vol. 22, No. 1, March 2007.