

판형 열교환기의 열전달과 유동특성에 대한 연구

김진화[†], 이광성, 지명국, 정한식*, 정효민*

경상대학교 대학원 정밀기계공학과, *경상대학교 정밀기계공학과 해양산업연구소

Study on Characteristics of Heat Transfer and Flow in Plate Heat Exchanger

Zhen-Hua Jin[†], Kwang-sung Lee, Myoung-Kuk Ji, Han-Shik Chung* and Hyo-Min Jeong*

Department of Mechanical and Precision Engineering, Gyeongsang National University, Korea

*Department of Mechanical and Precision Engineering, Gyeongsang National University, Institute of Marine Industry, Korea

ABSTRACT: In present work, experiments conducted to investigate the heat transfer characteristics and relationship between operating parameters and production of fresh water as output of the system. Plate Heat Exchanger (PHE) applied in vacuum evaporator for product fresh water that system intended to efficiently use low grade heat. PHE have become popular in chemical, power, food and refrigeration industries due to the efficient heat transfer performance, extremely compact design and flexibility of extend or modify to suit changed duty. The heat transfer part contains corrugated plates with 60 degree of chevron angle which verified by many researchers and commonly apply. Fresh water can be produced from saline water under near vacuum pressure by operating ejector. Consequently, evaporating temperature stay around 51-57 °C so it is possible to use any low grade heat source or renewable source. The maximum fresh water produced by freshwater generator with plat heat exchanger applied in the study was designed as 1.0 Ton/day.

Key words: fresh water generator, plate heat exchanger, heat transfer, pressure drop

Nomenclature

b mean channel gap [m]
 De equivalent diameter [m]
 Dp port diameter [m]
 f friction factor
 G mass velocity [kg/m²·s]
 h convective heat transfer coefficient [W/m²·°C]
 k thermal conductivity [W/m²·°C]
 n number of channel
 Re Reynolds number

Superscript

β chevron angle
 μ viscosity

Subscript

c channel

1. INTRODUCTION

In desalination system it is no doubt heat exchanger is extremely important as a key point. The importance of heat exchanger has increased immensely from the view point of energy conservation, conversion, recovery and successful implementation of new energy sources.⁽¹⁾

[†] Corresponding author

Tel.: +82-55-646-47661; fax: +82-55-640-3188

E-mail address: jinzhenhua@gnu.ac.kr

Nowadays PHE widely use in different industries such as chemical, food and pharmaceutical process and refrigeration. The heat transfer occurred between adjacent channels through plates. Alternate plates are assembled such that the corrugations on successive plates contact and cross each other to provide mechanical support to the plate pack through a large number of contact points. This resulting flow passages are go through a narrow, highly interrupted and tortuous so that will enhance the heat transfer flow and increasing the level of turbulence. At the same time, pressure drop will be accompanied inevitably. True flexibility is unique to the plate heat exchanger both in initial design and after installation. In the initial design the basic size, geometry, total number and arrangement of standard plates can easily be selected to precisely fit the specific duty. An existing plate heat exchanger can very easily be extended or modified to suit an increased or changed duty. Moreover, it is very compact and low in weight in spite of their compactness.⁽²⁻⁵⁾

Plate patterns have great influence on both of thermal and hydraulic performance, the final design is certainly depends on the initial choice of plate pattern. Although many types have been used in the past, the chevron type plate has proved to be the most successful model during last decades. A comprehensive step of design method was presented by Shah and Focke.⁽⁶⁾ The commonly used chevron angle varies between 30° to 60°. This been verified by many researchers according to experimental results and simulations already. An analytical study has been made by Martin⁽⁷⁾ to predict the performance of chevron type plate heat exchanger.

The main objective of this paper is discussing main conception of plate heat exchanger applied in vacuum evaporator for product fresh water. Especially focus on the

evaporating and condensing performance for product water. Besides, flow mal-distribution is common in reality that significantly reduces the heat exchanger performance. Thus, simulation conducted flow distribution in a PHE with 6 channels and used k-ε standard turbulence model.

2. Experimental Apparatus and Test Procedure

2.1 Experimental device

The concept of a fresh water generator is simple the sea water is evaporated using a heat source, separating pure water from salt, sediment and other elements. Fresh water generators usually attempt to use existing heat to run it in order to reduce cost of operation. There are two main elements in a fresh water generator, one heat exchanger evaporates the sea water and another one condenses the fresh water vapour into liquid phase for usage. In the condenser element, the vapour is condensed by cold seawater. We built Schematic diagram of fresh water generator experimental device as Fig. 1.

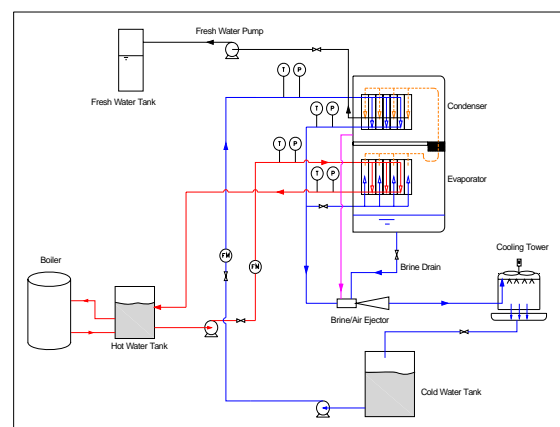

Fig. 1 Schematic diagram of the facility of fresh water generator system.

2.2 Experimental method

The heat transfer part contains corrugated plates with 60 degree of chevron angle which

verified by many researchers and commonly apply. Moreover the plate package arranged with U type configuration. The air inside the evaporation chamber is evacuated to a near vacuum, hence the saturation point of water becomes lower much more. It then becomes possible to evaporate the seawater at a temperature around 60 °C. The engine jacket cooling water is sufficiently hot to evaporate the water and it is commonly used. In present system saturation temperature located in the range of 51°C-57°C. The system may divide to main circuits. One is cold water circuit that cold fluid is supplied to the heat exchanger where it receives heat from the hot fluid across the plates. Finally the cold water delivered to cooling tower where temperature cool down and maintain at the inlet condition of heat exchanger. This experiment used city water. Since it assumed that the water temperature is constant. In the other hand, the hot fluid is flowing to the plate heat exchanger and fed back to hot water tank where is keep at a constant temperature using boiler.

The procedure of experiment firstly operate cold fluid circuit to obtain near vacuum condition in the tank which contains the heat exchanger. Further step is operating hot water circuit to supply hot water to heat transfer with the cold fluid between alternate plate channels of heat exchanger. It should be notice that there is bypass line connected from outlet of cooling water provide to evaporator. The pre heated cooling water supplied to absorb heat from hot water so that can be evaporating much more quickly and use the heat energy sufficiently. The temperature and pressure at inlet and outlet of fluids are recorded respectively till the steady state is reached. Same procedure has been repeated with different flow rate and supply temperature of hot fluid.

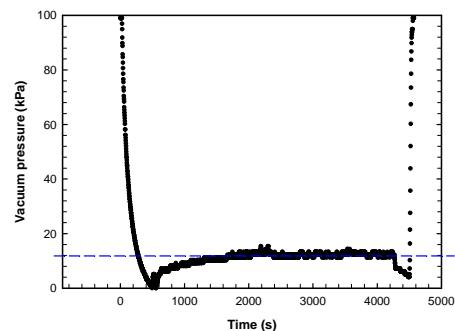

Fig. 2 Variation of vacuum pressure in the vessel.

As mentioned above the vessel contains two unit of exchanger is maintained with vacuum condition while the system is operating. The pressure variation in the inside of vessel is show as Fig. 2. This is one of experimental results with operate system exactly operate ejector entrain the inside air so that pressure decrease rapidly within 10 minutes. At this condition flowing hot stream and cold stream to start to exchange heat. We can see inside pressure increase gradually since there are vapour occurred. However through some period it maintain at steady state along 12kPa vacuum pressure relatively. It showed sharp increasing at end of part this because stop ejector and it recovery to atmosphere condition. In this way one circle of experiment is complete.

3. Results and Discussion

According to above mentioned concept and procedure, the experiments conducted at the range of 60 °C, 65 °C and 70 °C for the setting temperature at hot fluid respectively. Meanwhile the flow rate of fluid is set at 3.0m³/h and 3.5 m³/h.

First look at pressure drop that it is calculated as approximately 1.5 times the inlet velocity head per pass. Since the entrance an exit losses in the core cannot be determined by experimentally, they are included in the

friction for the given plate geometry. Although the momentum effect is negligibly small for liquids, it is also included in the following expression. The pressure drop or rise caused by elevation of change for liquids. Summing all contributions, the pressure drop on one fluid side in a plate heat exchanger is given by

$$\Delta P = \frac{1.5G_p^2 n_p}{2g_c \rho_i} + \frac{4fLG^2}{2g_c D_e} \left(\frac{1}{\rho} \right)_m + \left(\frac{1}{\rho_o} - \frac{1}{\rho_i} \right) \frac{G^2}{g_c} \pm \frac{\rho_m g L}{g_c}$$

$$f = 0.8 \text{Re}^{-0.25}, \quad \text{Re} = \frac{GD_e}{\mu}$$

$$G_p = \dot{m} / (\pi/4) D_p^2$$

where G_p is the fluid mass velocity at the port and n_p is the number of passes in the given fluid side, D_e is the equivalent diameter of flow passages namely twice of pressing depth(b), ρ_o and ρ_i are fluid mass densities evaluated at local bulk temperature and mean pressure at outlet and inlet, respectively. The Reynolds number is based on hydraulic diameter of the corrugated channel which is equivalent to twice of pressing depth of the plate.

A considerable amount of research has been conducted to determine heat transfer and flow friction characteristics of chevron plate. Martin provides comprehensive correlations for friction factors and Nusselt numbers for this geometry. The correlations for the fanning friction factor is

$$\frac{1}{\sqrt{f}} = \frac{\cos \beta}{(0.045 \tan \beta + 0.09 \sin \beta + f_0 / \cos \beta)^{1/2}} + \frac{1 - \cos \beta}{\sqrt{3.8 f_1}}$$

Where

$$f_0 = \begin{cases} \frac{16}{\text{Re}} \\ (1.56 \ln \text{Re} - 3.0)^{-2} \end{cases}, \quad f_1 = \begin{cases} \frac{149.25}{\text{Re}} + 0.9625 \\ \frac{9.75}{\text{Re}^{0.289}} \end{cases}$$

Martin also obtained the Nusselt number correlations as follows, using the momentum and heat transfer analogy from a generalized

Leveque solution in thermal entrance turbulent flow in a circular pipe.

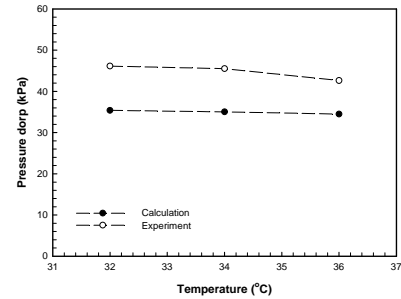

Fig. 3 Pressure drop by experiment and calculation of cold water side.

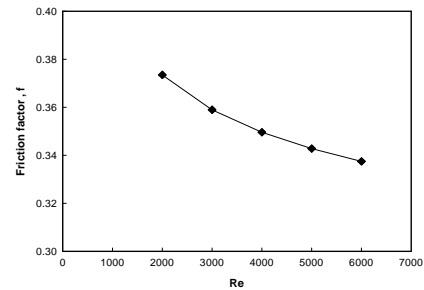

Fig. 4 Friction factor vs Reynolds number.

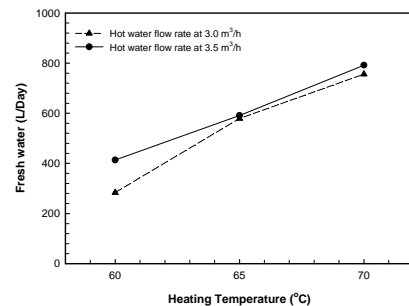

Fig. 5 Fresh water generation rate with temperature and different flow rate.

As the Reynolds number increases the heat transfer coefficient also increases, but friction factor decreases. Fig. 3 shows comparison of pressure drop between experimental and theoretical results based on the above equations. It is observed that there is difference for experimental results and calculation method which according to equation suggested by R. K. Shah. The calculation results ignored the third term of right hand side of equation since it is difficult to measure exact the density at each point. Additionally, in

experiment friction loss through pipeline is the inevitable. Thus this may result into the gap compare to experimental results. The friction factor decrease with increasing of Re number as show in Fig. 4.

Fig. 5 shows the fresh water generation at each supply temperature of hot water and flow rate. The line depicts the effect of flow rate and supply temperature of hot water on the fresh produce. It is showed that compare two lines it clear that fresh water generation rate is increasing proportionately by increase of hot water supply temperature. With different flow rate affect to the fresh water quantity is less at 65 °C and 70°C. However, the difference of fresh water quantity is become large at 60 °C of hot water temperature case. The reason for the difference might be due to when the hot water temperature is lower, the cold water outlet temperature will lower too so that for evaporating the temperature gap is large than other case at high temperature, similarly there need much more amount of heat and time to accumulate then it can be evaporated. Since the supply temperature is lower relatively. Hence, resulted into evaporating is not happened sporadically at this condition.

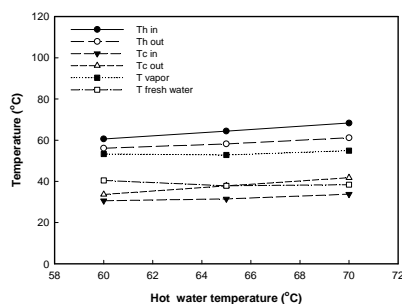

Fig. 6 Temperature variations with flow rate of 3.5m³/h.

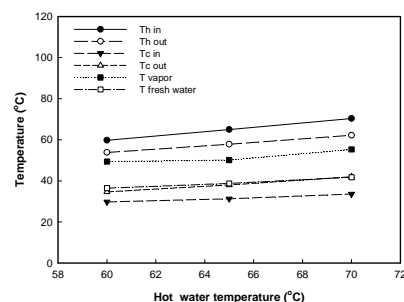

Fig. 7 Temperature variations with flow rate of 3.0m³/h.

Fig. 6 and Fig. 7 show the temperature distribution with flow rate of hot water at 3.0m³/h and 3.5m³/h. It shows temperature is increasing gradually with increase of hot water supply temperature. It is observed the temperature of fresh water is higher in case of 60°C than other because the generation rate is smaller than other case.

4. Numerical Analysis

A large number of optimization techniques are available from literature and quite a lot of commercial optimization software. CFD can provide another method approach to modeling and investigate performances. Moreover, there are a number of papers trying to approach other way namely numerical simulation like described in the articles.⁽⁸⁻¹⁰⁾

The numerical simulation solved the flowing continuity equation, momentum equation and energy equations use commercial software Fluent 6.3.26. In this paper, a CFD model taken to simulate flow distribution in the plate channel. The dimension of plate model in length of 400 and width of 100mm, equivalent diameter is 7mm and the port diameter is 24mm. The fluid domains were modelled with properties of water. The simulation was solved use k-ε turbulence model.

Simulation model is corrugated one plate and 6 channel model with only plat shape as shown in Fig. 8. In the simulation with

corrugated model conduct 5 case which the Reynolds number increasing from 2000 to 6000. Fig. 9 shows pressure drop according to increasing of Reynolds number.

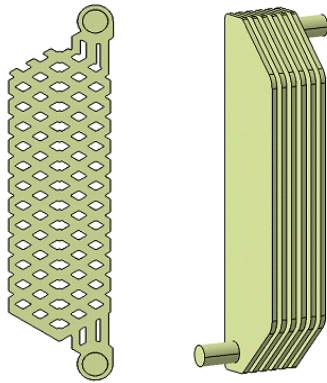

Fig. 8 Corrugate plate and flat multi channel model.

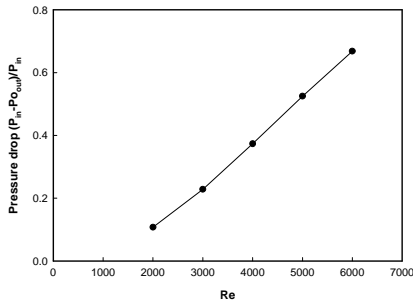

Fig. 9 Pressure drop according to Reynolds number.

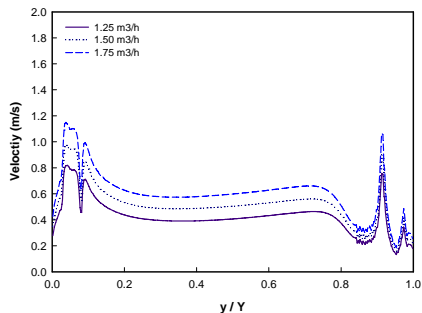

Fig. 10 Velocity distributions at the last channel in 6 channel unit.

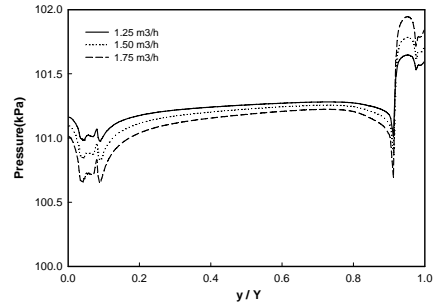

Fig.11 Pressure distributions at the last channel in 6 channel unit.

From Fig. 10 and Fig. 11 we can find more detailed variation of velocity and pressure along y direction cross port and plate channel. The y axis distance means location from bottom of channel. This data represent the cross port section along y direction. The simulation results indicate that pressure and velocity varied sharply around port due to changing of flow area. However at other area the distribution of pressure and velocity is near uniform.

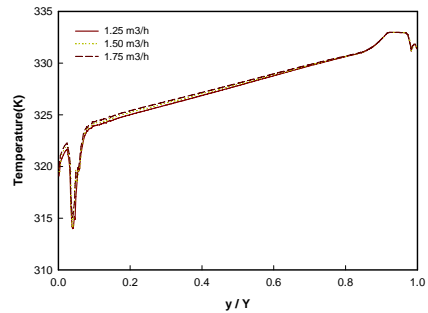

Fig. 12 Temperature distributions at the last channel.

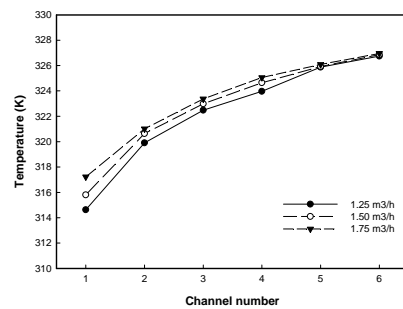

Fig.13 Temperature distributions located in different channel.

Fig. 12 shows the variation of temperature in the last channel. There is less influence by flow rate on the temperature distribution in this channel. However, Fig. 13 shows a little difference of temperature when the flow approach to end of channels the influence is increasing. Moreover, we can see the temperature distribution within 6 channels that there happens maldistribution as estimated. In the first channel bottom area temperature appears lower than other area. Since less amount of fluid flowing to this channel relatively compare to other channel. Therefore it considered if the channel made in various deferent depth size for heat transfer more sufficiently. This work will be continued in further research.

5. Conclusion

In the present work, we discussed about fresh water generator system which used plate heat exchanger to evaporate and condense with vacuum conditions. Experiments have been carried out on the fresh water generating according to the supply temperature and flow rate of heating medium and show the influence on the performance of product fresh water as outcome of the system.

The experiment show that with higher hot water supply temperature can produce more quantity of fresh water. The flow rate of hot water supply temperature affect less to the produce of fresh water in the range of high temperature. However, it can achieve more amount of fresh water at lower flow rate. Because at lower flow rate heat transfer sufficiently between hot medium and cold medium through adjacent plates. The simulation results indicate that pressure and velocity varied sharply around port due to changing of flow area. It observed that pressure drop significant with increasing of Reynolds number. In the 6 channel model the

flow rate is less effect on temperature but approach to end of channel the influence is increasing.

ACKNOWLEDGEMENT

This research was financially supported by Regional Industrial Common Technology Development from Ministry of Knowledge Economy. The Authors would like to thank the Human Resource Training Project for Regional Innovation from the Ministry of Education, Science Technology (MEST) and Korea Industrial Technology Foundation(KOTEF) and Brain Korea 21 Project.

REFERENCES

1. Khawaji, A. D., Kutubkhanah, I. K. and Wie, J. M., 2008, Advances in seawater desalination technologies, *Desalination*, Vol. 221. pp. 47-69.
2. Zahid, H. A., 2003, Plate heat exchanger literature survey and new heat transfer and pressure drop correlations for refrigerant evaporators, *Heat Transfer Engineering*. Vol. 24, No. 5, pp. 3-16.
3. Bobbili, P. R., Sunden, B. and Das, S. K., 2006, An experimental investigation of the port flow maldistribution in small and large plate package heat exchangers, *Applied Thermal Engineering*, Vol. 26, pp. 1919-1926.
4. Srihari, N. and Das, S. K., 2006, Transient response of multi-pass plate heat exchangers considering the effect of flow maldistribution, *Chemical Engineering and Processing*, Vol. 47. pp.695-707.
5. Rao, B. P., Kumar, P. K. and Das, S. K., 2002. Effect of flow distribution to the channels on the thermal performance of a plate heat exchanger, *Chemical Engineering and Processing*, Vol. 41, pp.49-58.
6. Shah, R. K. and Focke, W. W., 2003, Plate heat exchanger and their design theory in

heat transfer equipment design, Hemisphere, Washington, USA.

7. Martin, H., 1996, A theoretical approach to predict the performance of chevron-type plate heat exchangers, *Chemical Engineering and Processing*, Vol.1 35, pp. 301-310.
8. Fernandes, C. S., Dias, R. P., Nobrega, J. M. and Maia, J. M., 2007, Laminar flow in chevron type plate heat exchangers: CFD analysis of tortuosity, shape factor and friction factor, *Chemical Engineering and Processing*, Vol .46, pp. 825-833.
9. Zhang, G. M., Tian, M. C. and Zhou, S. J., 2006, Simulation and analysis of flow pattern in cross-corrugated plate heat exchanger. *Journal of Hydrodynamics*. Vol. 18. No. 5, pp. 547-551.
10. Noh, S. J., 2004, Numerical study of heat transfer and pressure drop in chevron type plate heat exchanger. Thesis. pp. 8-49.