

TOWARDS A MODEL OF THE DIGITAL UNIVERSITY: A GENERALIZED NET MODEL FOR PRODUCING COURSE TIMETABLES

A. Shannon¹, D. Orozova², E. Sotirova^{2,3}, K. Atanassov², M. Krawczak³, P. Melo-Pinto²,
R. Nikolov³, S. Sotirov³, T. Kim⁴

¹Warrane College, University of New South Wales, Kensington 1465 &
Raffles College, North Sydney, NSW 2060, Australia

²CLBME - Bulgarian Academy of Sciences,
Acad. G. Bonchev Str., Bl. 105, Sofia-1113, Bulgaria

³“Prof. Asen Zlatarov” University, Bourgas-8000, Bulgaria
e-mail: esotirova@btu.bg, ssotirov@btu.bg

⁴Division of General Education-Mathematics,
Kwangwoon University, Seoul 139-701, South Korea

Keywords: Generalized nets, University, E-Learning.

Summary

In a series of research papers, the authors have studied some of the most important models of a contemporary universities, such as: *the research university*, *the entrepreneurial university* and *the digital university* and construct their Generalized Net (GN) models. This paper is based on the case-studies of Sofia University, the Technical University of Munich and the University of Edinburgh. The main focus is to put the analysis of the processes of the functioning of a university which effectively integrates Information and Communication Technologies (ICT) in all university activities. A concrete example based on the process of course administration at University of Edinburgh is considered. This university is in a process of developing an integrated information system covering most of the university activities. The opportunity of using GNs as a tool for modeling such processes is analyzed as well.

1. Introduction

The wide penetration of Information and Communication Technologies (ICT) into society has catalyzed the need for a global educational reform which will break the monopoly of the print and paper based educational system. The ICT based distance education is considered as “*the most significant development in education in the past quarter century*” [7]. The pattern of growth in the use of ICT in higher education can be seen through [11]:

- increasing computing resources, including web-based technologies, encouraging supplemental instructional activities; a growth of academic resources online; and administrative services provided through networked resources;
- organisational changes in policies and approaches;

- an increasing emphasis on quality of teaching and the importance of staff development;
- changes in social practice, e.g. a growth in demand for life long learning opportunities, which consequently affect the need to adapt technology into instructional delivery; and an increase in average age of students.

One of the main conclusions related to the ongoing educational reform is that it is based on designing and using different virtual learning environments which do not put clear boundary between physical and virtual worlds. A key factor for success is to integrate them, not to separate them, and to apply relevant instructional design strategy based on a current learning theory. A tool for implementing such learning environment is an integrated information system which provides services and supports all university activities. Such an integrated system could drive the transformation of a university towards a *digital university* [3], in parallel with implementation of some other university models, such as: *the research university* [4] and *the entrepreneurial university* [5].

In the present paper a Generalized net (GN; see [1, 2]) model of the digital university will be constructed.

2. Towards Implementation of a Digital University Model

There exist many higher education projects aiming at integrating ICT into all university activities. For example, Sofia University commenced such a project in February, 2002 [14]. The main goal of the project was to develop a general institutional and technological framework for ensuring better quality of education by integration and optimization of the existing and attracting additional resources. The project has three main components:

- Development of an institutional framework for quality assurance, including a framework for integration of the European Credit Transfer System (ECTS) in the university.
- Development of a prototype of an integrated information system with an embedded framework for quality assurance and a platform for e-learning and team-work;
- Development of a university multi-media resource centre for foreign language study based on the European Language Portfolio.

The first two components were successfully developed and a process of wide implementation of the prototype of the integrated information system is under way now. One of the main problems identified during the process of development was the lack of clear description of the university processes. The implementation of the pilot information system in the educational activities catalyzed the need of a more formal description and modeling of these processes in order to develop a complete "*Digital Campus Environment*" [15].

The Technical University in Munich is developing a Digital University project as well [3]. The university is realigning its ICT strategically in co-operation with the Leibniz Supercomputing Centre. This realignment is accomplished under guidance of the Chief Information Officer (CIO) in accordance with the overall university strategy by means of closely interconnected projects in the areas of organisation, campus management, eLearning and ICT infrastructure. They found a basis of success in

standardisation of the organisational and technical solutions as well as the university-wide integration of all groups involved.

In 2004 the University of Edinburgh started a “*change project which would include the implementation of a new student system, as well as fundamentally reviewing the way processes were carried out to identify shared solutions*” [6]. The primary objective of the project is to develop a “*streamlined, modern approach to interacting with enquirers, applicants and students which reflects our international standing and the calibre of our teaching and research*”. This will involve:

- using online technology to communicate with speed and facilitate global access
- reducing paperwork so that the focus is on core University activities - teaching, research and supporting students and the university
- developing integrated, efficient processes to be used across the university
- sharing a single student system that provides accurate student information to everyone who needs it

In order to build a of a contemporary university one should consider also the model of the Research University [4]. The model of a Research University could be considered as among the most successful models for building research and educational capacity in universities. While most European universities try to integrate education, research and innovation at the Masters and Doctoral level, many of the American research universities target the Bachelors level as well. The research universities could be both student-centered and research-centered through a synergistic system in which faculty and students are learners and researchers, whose interactions make for a healthy and flourishing intellectual atmosphere. The research universities typically integrate information technology in all university activities. Because such universities create technological innovations, their students should have the best opportunities to learn state-of-the-art practices — and learn to ask questions that stretch the uses of the technology. The concept of integrated education at a research university requires restructuring both the pedagogical and the management aspects of the university based on an effective use of information technology.

Another model is provided by the framework of the “Entrepreneurial University” defined by Clark [5]. The main characteristic of such university is that it “*understands the commercial value of knowledge*”. Clark identifies five elements that constitute the irreducible minimum of entrepreneurial actions for an entrepreneurial university. The degree of implementation of each of these actions provides some good indicators for successful transformation of a university towards the framework of an entrepreneurial university. These actions are:

- strengthening the steering core;
- expanding the developmental periphery;
- diversifying the funding base;
- stimulating the academic heartland;
- integrating the entrepreneurial culture.

Building a synergetic university model incorporating the characteristics of the three mentioned above models could be a direction of research for many scholars. Implementation of a prototype of such model is under development at Sofia University [8, 9, 10, 15]. This model, however, should be based on a set of formally

defined university processes. The next paragraphs present the opportunity to of using Generalized Nets as a tool for modeling such processes, which will give some instruments for capturing their dynamics. A concrete example based on the process of course administration at University of Edinburgh is considered further on.

3. A GN-model

The GN-model (see Fig. 1) contains 5 transitions and 20 places, collected in two groups and related to the two types of the tokens that will enter respective types of places:

α - tokens and l -places represent the input data necessary for producing of course timetable,

β - tokens and t -places represent the timetable.

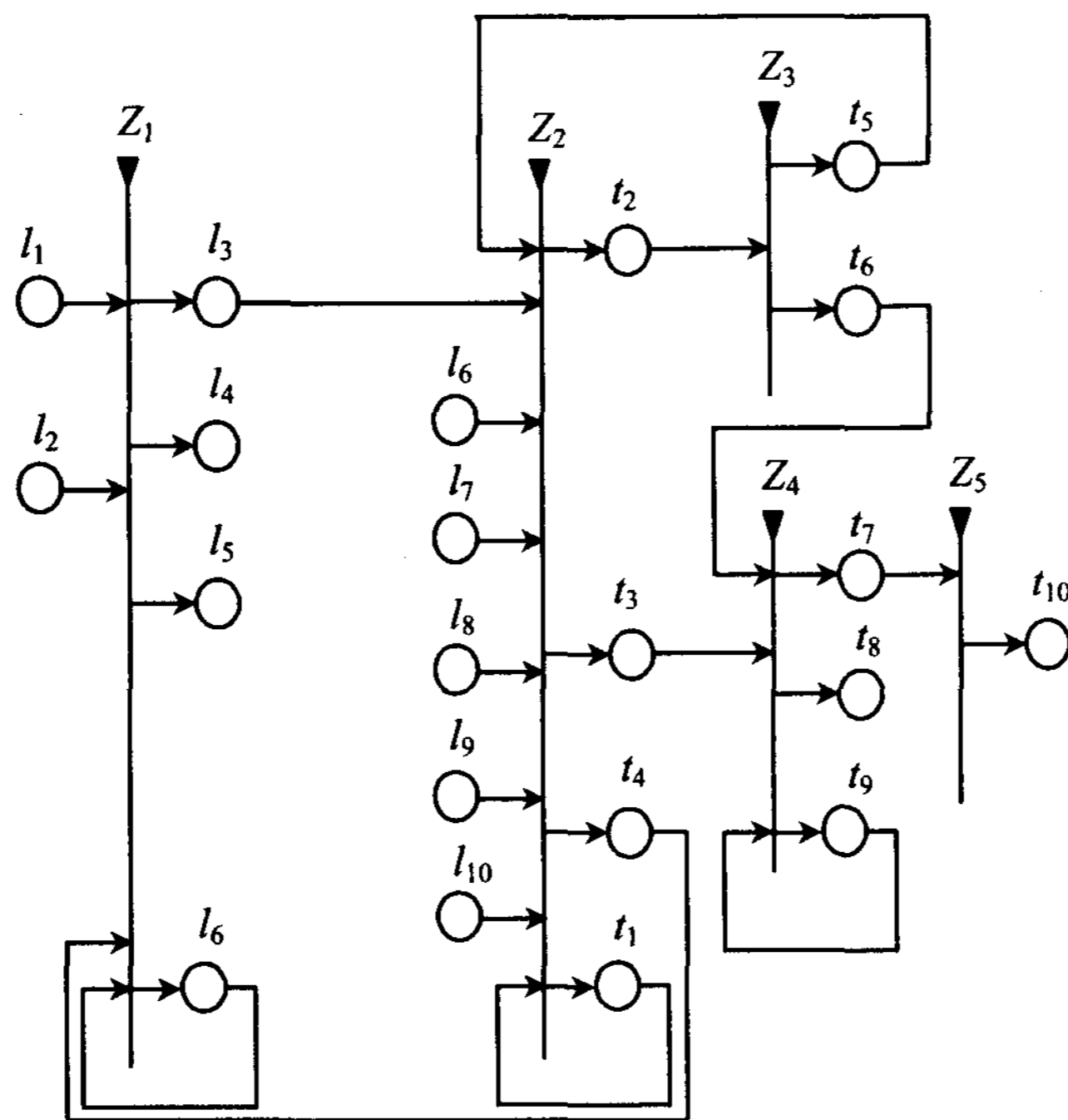

Figure 1: GN model of process of produce course timetable

For brevity, we shall use the notation α - and β -tokens instead of α_i - and β_j -tokens, where i, j are numerations of the respective tokens.

In the beginning β -tokens stay in place t_1 with initial characteristic:
 “Initial (existing) timetable”.

In the next time-moments this token is split into two. One of them, let it be the original β -token, will continue to stay in place t_1 , while the other β -token will move to transitions Z_1, Z_4, Z_5, Z_6 , passing via transition Z_3 .

All tokens that enter transition Z_2 will unite with the original token. All information will be put as an initial characteristic of a token, generated by the original token.

The α -tokens with characteristics
 “Cancelled course data”

and

“Live course data”

enter the net via places l_1 and l_2 respectively.

From place t_5 comes a β -token with information for changing course data.

These data come from a variety of centrally and locally held systems with the University.

The α -tokens with characteristics

“Course requirement”,
 “Student requirement”,
 “Non central rooms available”,
 “Teaching load model”,

and

“Student number information”

enter the net via places l_6, l_7, l_8, l_9 and l_{10} , respectively.

The forms of the transitions are the following.

$$Z_1 = \langle \{l_1, l_2, l_6, t_4\}, \{l_3, l_4, l_5, l_6\}, r_1, \vee (\wedge(l_1, l_2), t_4, l_6) \rangle$$

where:

	l_3	l_4	l_5	l_6	
l_1	<i>false</i>	<i>false</i>	<i>false</i>	<i>true</i>	
$r_1 = l_2$	<i>false</i>	<i>false</i>	<i>false</i>	<i>true</i>	,
l_6	$W_{6,3}$	$W_{6,4}$	$W_{6,5}$	<i>false</i>	
t_4	<i>false</i>	<i>false</i>	<i>false</i>	<i>true</i>	

$W_{6,3}$ = “The course delivery data is updated”,

$W_{6,4}$ = “The first meeting date is sent to Timetab”,

$W_{6,5}$ = “The information is fed into WebCT”.

The α -tokens obtains the characteristics:

“Concrete parameters of the updated course delivery data”

in place l_3 ,

“Concrete information for the first meeting date to Timetab”

in place l_4 , and

“WebCT feed”

in place l_5 .

$$Z_2 = \langle \{l_3, l_7, l_8, l_9, l_{10}, l_{11}, t_1, t_5\}, \{t_1, t_2, t_3, t_4\}, r_2, \vee (\wedge(l_3, l_7, l_8, l_9, l_{10}, l_{11}), l_1, l_5) \rangle,$$

where:

	t_1	t_2	t_3	t_4
l_3	<i>true</i>	<i>false</i>	<i>false</i>	<i>false</i>
l_7	<i>true</i>	<i>false</i>	<i>false</i>	<i>false</i>
l_8	<i>true</i>	<i>false</i>	<i>false</i>	<i>false</i>
$r_2 = l_9$	<i>true</i>	<i>false</i>	<i>false</i>	<i>false</i>
l_{10}	<i>true</i>	<i>false</i>	<i>false</i>	<i>false</i>
l_{11}	<i>true</i>	<i>false</i>	<i>false</i>	<i>false</i>
t_1	<i>false</i>	<i>true</i>	<i>true</i>	<i>true</i>
t_5	<i>true</i>	<i>false</i>	<i>false</i>	<i>false</i>

The α -tokens that enter places t_2 , t_3 and t_4 obtain characteristic
 “The values of the completed timetable”.

$$Z_3 = \langle \{t_2\}, \{t_5, t_6\}, r_3, \wedge(t_2) \rangle,$$

where:

$$r_3 = \frac{t_5 \quad t_6}{t_2 \quad W_{2,5} \quad W_{2,6}}.$$

$W_{2,5}$ = “The timetable is not correct”;

$W_{2,6}$ = “The timetable is correct”.

The α -tokens obtains the characteristics:

“Revision query”

in place t_5 and

“Verified timetable”

in place t_6 .

$$Z_4 = \langle \{t_6, t_3, t_9\}, \{t_7, t_8, t_9\}, r_4, \vee(\wedge(t_6, t_3), t_9) \rangle$$

	t_7	t_8	t_9
$r_4 = t_3$	<i>false</i>	<i>false</i>	<i>true</i>
t_6	<i>false</i>	<i>false</i>	<i>true</i>
t_9	<i>true</i>	<i>true</i>	<i>false</i>

The α -tokens have the characteristics:

“Published final form of the course timetable”

in place t_7 , and

“Concrete tutorial/Lab details”

in place t_8 .

$$Z_5 = \langle \{t_7\}, \{t_{10}\}, r_5, \wedge(t_7) \rangle,$$

where:

$$r_5 = \frac{t_{10}}{t_7 \quad true}.$$

The α -tokens take on the characteristics:

“Initially allocated tutors/demonstrations”

in place t_{10} .

4. Conclusion

The GN-model constructed in this way is the initial one in a series of research exercises which the authors are currently preparing and which are a continuation of the previous ones, collated in [12, 13].

References

- [1] Atanassov, K., *Generalized Nets*. Singapore/New Jersey: World Scientific, 1991.
- [2] Atanassov, K. *On Generalized Nets Theory*. Sofia: Prof. M. Drinov Academic Publishing House, 2007.
- [3] Bode, A., Borgeest, R., Pongratz, H. (2007), The ICT Strategy of the Technische Universität München, EUNIS 2007 “*Innovation for a European ERA*”, June 26-29th.
- [4] Boyer Commission. *Reinventing Undergraduate Education: A Blueprint of America’s Research Universities*, Technical Report, <http://naples.cc.sunysb.edu/Pres/boyer.nsf/>, 1998.
- [5] Clark, B. R.. *Creating Entrepreneurial Universities, Organisational Pathways of Transformation*. Oxford: Pergamon, 1998.
- [6] EUCLID, <http://www.projects.ed.ac.uk/euclid/>
- [7] Moore, M.G. (2003). Preface, in: Moore, M.G. and Anderson, W., Eds. (2003). *Handbook of Distance Education*. Philadelphia: Lawrence Erlbaum Associates, Inc.
- [8] Nikolov, R. (2003), Towards Education and Training as a Meta-Industry, *World Bank Knowledge Economy Forum*, Helsinki, March 25-28, http://www.worldbank.org/eca/helsinki/torstai/ilpotapio/bulgaria/Bulgaria_case_study.doc, <http://www.worldbank.org/eca/helsinki/torstai/ilpotapio/bulgaria/ie.html>
- [9] Nikolov, R., Ilieva, S. (2007), *Building a Research University Ecosystem: the Case of Software Engineering Education at Sofia University*, ESEC/FSE 2007 Conference, Widened Software Engineering track, Dubrovnik, 3-7 September.
- [10] Nikolov, R., Ilieva, S. (2008), A Model for Strengthening the Software Engineering Research Capacity, SEESE Workshop on ICSE 2008 (in press).
- [11] Price, S., et al, Review of the impact of technology-enhanced learning on roles and practices in Higher Education, <http://www.lonklab.ac.uk/kscope/impact/dmdocuments/Reviewdocument.pdf>
- [12] Shannon A., Atanassov K., Orozova D., Krawczak M., Sotirova E., Melo-Pinto P., Petrounias I., Kim T. *Generalized Nets and Information Flow within a University*. Warsaw: Warsaw School of Information Technology, 2007.
- [13] Shannon, A., D. Langova-Orozova, E. Sotirova, I. Petrounias, K. Atanassov, M.Krawczak, P. Melo-Pinto, T. Kim. *Generalized Net Modelling of University Processes*. North Sydney: KvB Visual Concepts Pty Ltd, Monograph No. 7, 2005.
- [14] Improving the Quality of Education at Sofia University through Integration of the Intellectual and Information Resources, internal document.
- [15] Sofia University Electronic Campus (SUECampus), (*Digital University Integrated ICT System*), internal document.