

# Two-Stage Charge Equalization Scheme for Hybrid Electric Vehicle Lithium-Ion Battery Cells

Hong-Sun Park, Chong-Eun Kim, and Gun-Woo Moon  
Division of Electrical Engineering, KAIST

Joong-hui Lee  
Corporate R&D center, SK Corporation,

## Abstract

Two-stage charge equalization scheme for HEV lithium-ion battery string is proposed with the optimal power rating design rule in this paper, where in the first stage the over charged energy of higher voltage cells is drawn out to the single common output capacitor and then, that discharged energy is recovered into the overall battery stack in the second stage. To achieve charge equalization of sort, the conventional flyback DC/DC converters of low power and minimized size are employed. The industrial sample employing both the proposed two-stage cell balancing scheme and the optimal power rating design rule shows good cell balancing performance with reduced size as well as low voltage stresses of the electronic devices.

## 1. Introduction

HEV has become one of the most promising vehicles in the automotive markets due to its ability of energy saving and low emission of CO<sub>2</sub> [1]. This is because a HEV can recover energy from the wheels, which have been wasted in the past, and then reuse it to propel the vehicle at low speeds or boost extra power required in high acceleration. The greater part of HEVs on the streets of these days uses nickel-metal hybrid (Ni-MH) batteries [1]. Recent development of lithium-ion battery and its test result show that the lithium-ion battery has higher power and energy density, lower self-discharge rate, and higher single cell voltage than the Ni-MH battery such that it has the potential of taking the place of Ni-MH battery in the HEVs of the future [2], [3]. However, to realize this possibility, reliability and safety should be first of all ensured; in other words, the lithium-ion battery should be maintained within the ranges of the allowed voltage and current limits to prevent permanent deterioration of characteristics and, in the worst case, explosion or fire in the vehicle [1], [3]. To avoid this critical situation in advance, a charge equalization circuit for series connected lithium-ion battery string is necessary.

## 2. Proposed Two-stage cell balancing scheme

### 2.1 Circuit description

Fig. 1 shows the proposed two-stage charge equalization converter for the HEV lithium-ion battery cells, in which the first stage is for discharge of over charged energy from a few of higher voltage cells and the second stage is for recovery of the discharged energy into the overall battery string. To realize this cell balancing scheme, each cell has its own flyback DC/DC converter of compact size to release the over charged energy into the common output capacitor individually and the second stage employs only one flyback DC/DC converter to recover this discharged energy into the whole battery stack. The proposed two-stage cell balancing scheme has been developed in nature to remove the high voltage stresses of the electronic devices in the equalization circuit

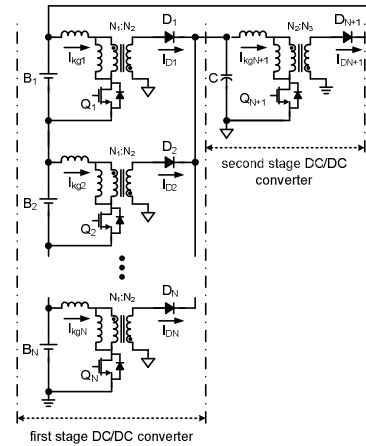

Fig. 1. Proposed two-stage charge equalization converter.

for the HEV battery system while in advance preventing the over voltage problem of the lithium-ion battery.

### 2.2 Operational principles

The operational principles of the proposed charge equalization circuit are very simple and easy. Basically, the circuit operations consist of those of the two flyback DC/DC converters cascaded, where the two DC/DC converters of both stages operate in the different ways; in other words, the first stage DC/DC converter is driven with a fixed duty ratio by the centralized control of a BMS, while the second stage DC/DC converter is automatically self-driven by a close loop to regulate the voltage of the common capacitor.

- Mode 1 ( $t_0-t_1$ ): When  $Q_1$  and  $Q_N$  are turned on at the same time by an intelligent BMS, the primary currents,  $I_{kg1}$  and  $I_{kgN}$ , build up at the magnetizing inductors, respectively, as shown in Fig. 2(a) and Fig. 3.

- Mode 2 ( $t_1-t_2$ ): When  $Q_1$  and  $Q_N$  are synchronously turned off, the primary current of each cell flows into the common capacitor,  $C$ , of which input current consists of sum of  $I_{D1}$  and  $I_{DN}$  through the rectifier diodes,  $D_1$  and  $D_N$ , respectively.

- Mode 3 ( $t_2-t_3$ ): When the voltage of the common capacitor reaches the preset level,  $Q_{N+1}$  of the second stage is automatically turned on, and the primary current of the second stage,  $I_{kgN+1}$ , builds up at the magnetizing inductor as shown in Fig. 2(c).

- Mode 4 ( $t_3-t_4$ ): When  $Q_{N+1}$  is turned off,  $I_{kgN+1}$  is recovered into the overall battery stack as shown in Fig. 2(d) and Fig. 3. This current is called equalizing current or equalizing energy in this paper.

- Mode 5 ( $t_4-t_5$ ): When the equalizing current reaches zero, mode 5 begins. In this mode resonance caused by parasitic components in the circuit occurs, even though not specified in this paper, until the first stage DC/DC converters work again.

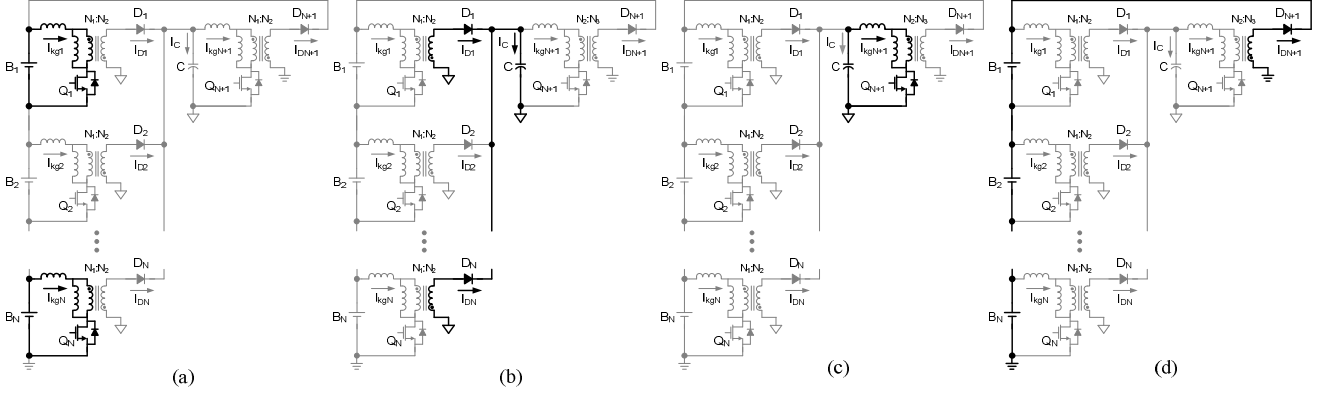

Fig. 2. Operational modes of the proposed circuit. (a) Mode 1. (b) Mode 2. (c) Mode 3. (d) Mode 4.

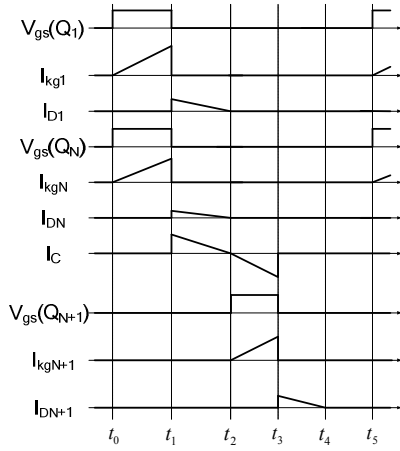

Fig. 3. Key waveforms of the proposed circuit.

The operational modes of this charge equalization circuit are repeated over and over again until the BMS turns off all the switches at the first stage.

### 3. Experimental results

To verify the operational principles of the proposed cell balancing circuit with the power rating design rule of optimum, an industrial sample is implemented and its circuit diagram is shown in Fig. 4 [4]. In this sample, the commercial 7Ah lithium-ion batteries of four cells are used for the HEV battery system and the flyback DC/DC converters, constructed by utilizing the proposed power rating design rule, are in parallel connected with both the battery stack at the first stage and the common capacitor at the second stage, respectively. The parameters used for realization of the industrial sample are described in TABLE I.

In this experiment, the initial SOC difference between the over charged cell and the others is approximately 20%, where only the second cell has the highest SOC among them. In this circuit, the first stage DC/DC converter for release of the over charged energy is driven in pulse width modulation mode with a fixed duty ratio, while the second stage DC/DC converter for recovery of the discharged energy is self-driven in the close loop with a variable duty ratio to regulate the voltage of the common capacitor. In addition, the first stage DC/DC converter is driven by isolation employing an opto-coupled gate driver. In fact, the cell equalization is a part of an intelligent BMS functions, but in this sample the start and the termination of cell equalization is manually controlled temporarily.

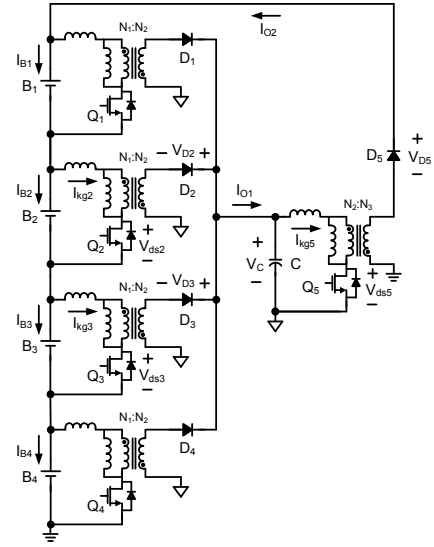

Fig. 4. Circuit diagram of the industrial sample employing the proposed two-stage charge equalization scheme.

Fig. 5 shows the experimental waveforms of the implemented industrial sample, in which the DC/DC converters which are coupled to the second and the third cell, respectively, are simultaneously driven to ensure that the proposed cell balancing circuit works fairly well even in the contemporary discharges of multiple cells. The experimental results show that both the second and the third cell discharge the extra energy to the common capacitor at the same time and then, the stored energy is recovered to the overall battery string. In addition, designing of low voltage of the common capacitor in the first stage, all of electronic components at the first stage have greatly low voltage stresses no matter how large plenty of cells are stacked expect for only the rectifier diode of one at the second stage.

To show the cell balancing performance of the proposed two-stage charge equalization circuit, equalization test cooperated with the lithium-ion battery cells is conducted and its result is plotted in Fig. 6. In this test, to achieve charge equalization within 68 minutes under the SOC difference of 20% between the over charged cell and the other cells, average input current of 1A is designed to flow into the first stage DC/DC converter of the second cell. As shown in Fig. 6, the industrial sample built by the proposed optimal power rating design rule shows the good equalization performance; in other words, equalization time of 70 minutes is consumed to achieve cell balancing. The measured efficiencies of the first and the second stage DC/DC converters of the industrial sample are 84% and 91%, respectively. From the

TABLE I  
PARAMETERS FOR THE TWO-STAGE CHARGE EQUALIZATION CIRCUIT

Parameters		Value	
First stage	Power switch, $Q_1-Q_4$	IRLML2502	
	Opto-coupled gate driver IC	FS9661A	
	Diode, $D_1-D_4$	MBR0540T1	
	Transformer	Core	EP41010
		$N_1:N_2$	12:42
$L_m, L_{kg}$		15 $\mu$ H, 520nH	
Second stage	Power switch, $Q_5$	IRFR1205	
	Diode, $Q_5$	10MQ060N	
	Transformer	Core	EP41313
		$N_2:N_3$	32:36
		$L_m, L_{kg}$	91 $\mu$ H, 2 $\mu$ H
Lithium-ion battery	Capacity	7Ah	
	SOC of $B_1$ at $t=0$	42.0%	
	SOC of $B_2$ at $t=0$	63.6%	
	SOC of $B_3$ at $t=0$	41.8%	
	SOC of $B_4$ at $t=0$	41.6%	

above experimental results, the two-stage charge equalization circuit and the optimal power rating design scheme proposed in this paper show the outstanding cell balancing performance with low voltage stresses of electronic devices and greatly reduced size of the cell balancing circuit while achieving cell equalization within the equalization time under the SOC distribution of imbalance.

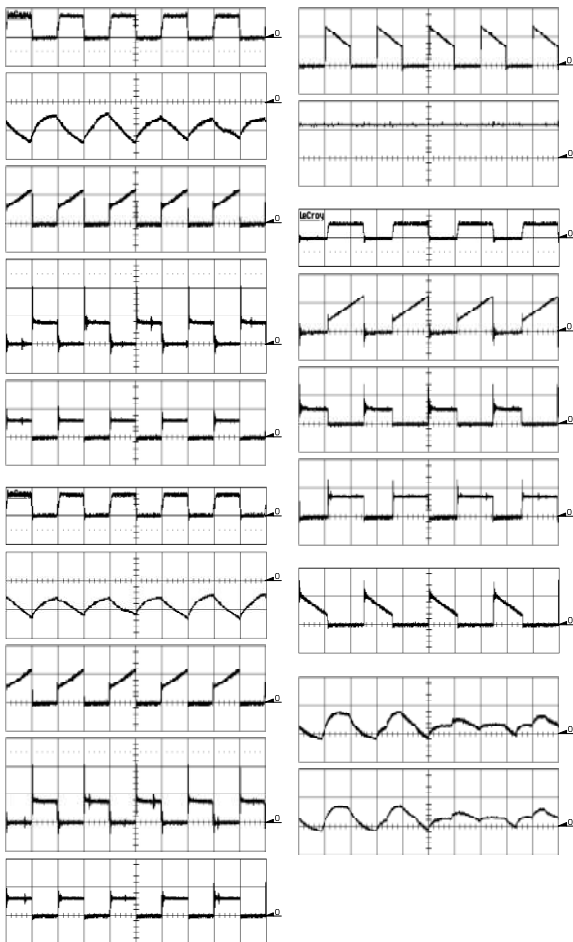

Fig. 5. Experimental waveforms of the industrial sample at the contemporary discharges of the second and the third cells.

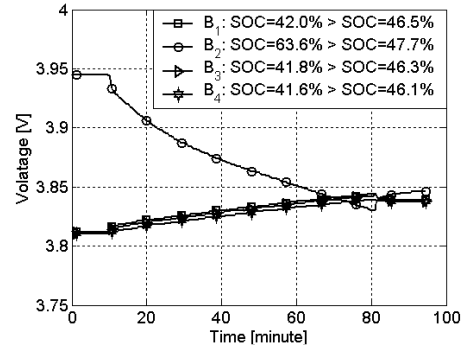

Fig. 6. Charge equalization performance of the proposed two-stage cell balancing circuit.

### 3. Conclusions

In this paper, two-stage cell balancing converter for HEV lithium-ion battery cells in series is proposed with the optimal power rating design scheme considering both equalization time and battery statistics of imbalance. In designing a cell balancing circuit for HEV lithium-ion battery cells, voltage stresses of electronic devices, size of a balancing circuit, and equalization time are considerably important factors. Taking the above factors into account, the proposed two-stage charge equalization circuit constructed by the optimal power rating design scheme has good cell balancing performance with low voltage stresses of all the electronic components except for only one rectifier diode as well as minimized size of the cell balancing circuit. The proposed two-stage cell balancing circuit and the optimal power rating design rule can be widely applicable to the series connected lithium-ion battery cells of HEV or EV.

### Acknowledgment

This work was supported through research fund by SK Corporation, Republic of Korea.

### Reference

- [1] D. S.- Repila and J. E. W. Poxon, "Hybrid electric vehicles: current concepts and future market trends," *J. Barcelona IEEE Student Branch*, vol. 13, pp. 5-30, Mar. 2006.
- [2] M. Inaba and Z. Ogumi, "Up-to-date development of lithium-ion batteries in Japan," *IEEE Electr. Insul. Mag.*, vol. 17, pp. 6-20, Nov./Dec. 2001.
- [3] N. Takeda, S. Imai, Y. Horii, and H. Yoshida, "Development of high performance lithium-ion Batteries for hybrid electric vehicles," *Mitsubishi Motors Technical Review*, pp. 68-72, Jan. 2003.
- [4] H. -S. Park, C. -E. Kim, G. -W. Moon, J. -H. Lee, and J. K. Oh, "Two-stage cell balancing scheme for hybrid electric vehicle Lithium-ion battery strings," in Proc. IEEE PESC '07, Orlando, USA, June 2007, submitted for publication.