

A Design of Wireless Sensor Network Based on ZigBee Technology in Petrochemical Industry

*Song Huang, *Qingsen Zhou, **Ke Zhang, *Heejong Suh

*Chonnam National University, San96-1, Dundok-dong, Yeosu-si, Jeollanam-do 550-749

**Beijing Institute of Petro-chemical Technology, Beijing 102617 China

E-mail : songgoo@gmail.com

Abstract

In this paper, the Wireless Sensor Network (WSN) based on ZigBee technology was devised and developed. Wireless communication was applied to petrochemical domain, like other industries. And sensor network of IEEE 802.15.4 protocol stack diagram was described. Then, by analyzing the protocol, the software systems included the communication protocol and point-to-point network were implemented with Freescale Semiconductor's product MC13192-SARD DSK board. After that, the performance of this design system was evaluated, and finally, by using PC Graphic User Interface (GUI) and IDE CW08 V3.1 programming tool, the real time communication data and the curve function were displayed.

I. Introduction

In this paper, the author proposes to use the advanced and reliable ZigBee™ which is a wireless technology to replace the signal wire and control wire. ZigBee™ technology is a low data rate, low power consumption, low cost, wireless networking protocol targeted towards automation and remote control applications, and it can suit the long-term environment industrial monitoring application.

II. Sensor network of IEEE 802.15.4 protocol stack

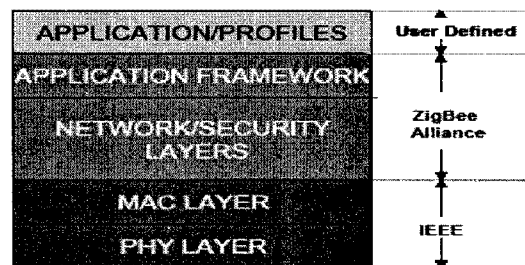

Fig. 1 IEEE 802.15.4 stack.

ZigBee/IEEE 802.15.4 - General Characteristics:

- Dual PHY (2.4GHz and 868/915 MHz).
- Data rates of 250 kbps (@2.4 GHz), 40 kbps (@915 MHz), and 20 kbps (@868 MHz).
- Optimized for low duty-cycle applications(<0.1%).
- CSMA-CA channel access Yields high throughput and low latency for low duty cycle devices like sensors and controls.
- Low power (battery life multi-month to years).
- Multiple topologies: star, peer-to-peer, mesh.
- Addressing space of up to: - 18,450,000,000,000 millions devices (64 bit IEEE address) - 65,535 networks.
- Optional guaranteed time slot for applications requiring low latency.
- Fully hand-shaked protocol for transfer reliability. Range: 50m typical (5-500m based on environment) [1], [2].

III. The system diagram and project scheme

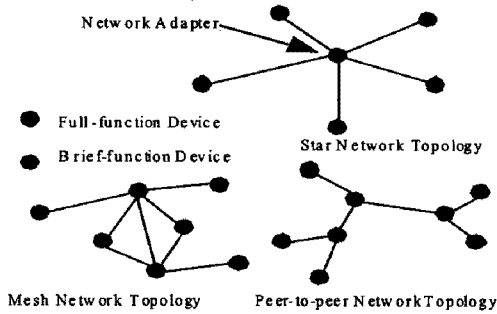

Fig. 2 ZigBee topology.

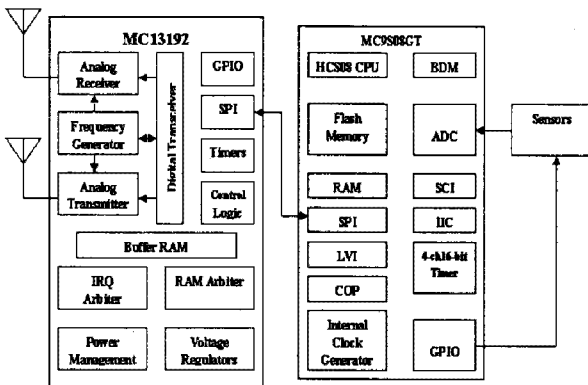

Fig. 3 System diagram of hardware platforms.

IV. Test results

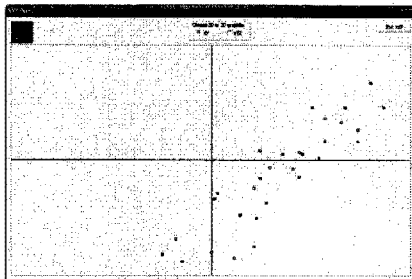

Fig. 4 Two dimensional display module.

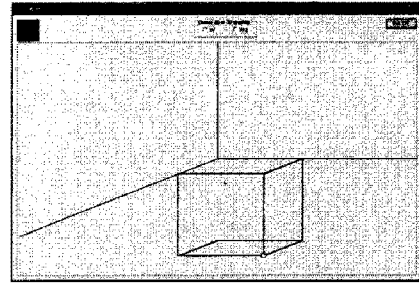

Fig. 5 Three dimensional display module.

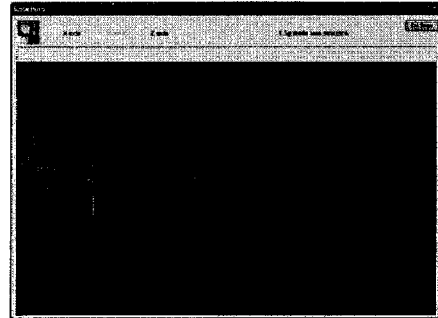

Fig. 6 The test of communication distance.

IV. Conclusions

This paper presents a ZigBee technology based WSNproject used in petrol-chemical industry. The theoretical analysis and the experiments confirm that this project design was reasonable, hardware system works normal, the software procedure compiled for WSN was correct. It implies great practical value. Believed that, with continuous progress of scientific technology, especial the overcoming of some key problems in sensor networks, the application prospect of this design was very optimistic in the petrochemical industry domain.

References

- [1] V-authors, ZigBee Specification, ZigBee Alliance, 14 December 2004.
- [2] ZigBee Alliance, <http://www.caba.org/standard/zigbee.html>.