

3D BUILDING RECONSTRUCTION FROM AIRBORNE LASER SCANNING DATA

Jeong-Ho Lee, Soo-Hee Han, Ki-Yun Yu, Yong-Il Kim

School of Civil, Urban and Geosystem Engineering, Seoul National University, ilome79@snu.ac.kr

School of Civil, Urban and Geosystem Engineering, Seoul National University, scivile2@snu.ac.kr

School of Civil, Urban and Geosystem Engineering, Seoul National University, kiyun@snu.ac.kr

School of Civil, Urban and Geosystem Engineering, Seoul National University, yik@snu.ac.kr

ABSTRACT: The demand for more accurate and realistic 3D urban models has been increasing more and more. Many studies have been conducted to extract 3D features from remote sensing data such as satellite images, aerial photos, and airborne laser scanning data. In this paper a technique is presented to extract and reconstruct 3D buildings in urban areas using airborne laser scanning data. Firstly all points in a building were divided into some groups by height difference. From segmented laser scanning data of irregularly distributed points we generalized and regularized building boundaries which better approximate the real boundaries. Then the roof points which are subject to the same groups were classified using pre-defined models by least squares fitting. Finally all parameters of the roof surfaces were determined and 3D building models were constructed. Some buildings with complex shapes were selected to test our presented algorithms. The results showed that proposed approach has good potential for reconstructing complex buildings in detail using only airborne laser scanning data.

KEY WORDS: Building, Airborne Laser, Building Reconstruction, 3D Building, LiDAR

1. INTRODUCTION

ALS (Airborne Laser Scanning) data has been widely used for generating Digital Elevation Models, detecting building boundaries and making 3D building models. In many cases, ALS data has replaced traditional feature extraction based on satellite imagery or aerial photos. This is because ALS system not only provides data with a very high accuracy but also is active in sensing, allowing for weather-free and time-flexible data collection. Especially ALS data have a high potential for 3D building extraction and reconstruction.

To extract and reconstruct buildings from ALS data, two methodologies can be used. One approach is to reconstruct buildings by using parametric primitives (Brenner, 2000). This method is usually useful in case that we reconstruct simpler buildings such as a rectangular parallelepiped. But the number of primitives is not large and most of them have rectangular footprints, so the level of detail which can be achieved may be reduced by parametric primitives. The other is to classify and segment the data into some planes and to make a polyhedral model by merging them. In the method of constructing polyhedral models, extracting the roof plane boundaries is the greatest problem. Edges where adjacent roof planes intersect can be detected precisely, whereas step edges that occur in case of height-jump or at building boundaries are poorly extracted. Therefore air photos or 2D GIS data such as digital map is often needed with ALS data to compensate such problems (Rottensteiner et al., 2004).

If there exist neither air photos nor digital maps, the roof boundaries must be extracted from ALS data. Approximate boundaries are determined from segmented

buildings points. However, these edges are not correct and in many cases their shapes are ragged or zigzagged. Furthermore, many algorithms assume that buildings have only rectangular corners.(Alharthy and Bethel, 2002, Vosselman, 1999). It degrades the level of detail in which buildings are delineated.

In this paper, we suggest a method which uses both parametric primitives and polyhedral models. The approach consists of three steps: segmentation, step edge determination and intersection edge determination. Using only ALS data, 2D polygons of building footprints which are not always rectangle but may be arbitrary are extracted. To determine more accurate edge, boundary regularization is conducted. Step edges are determined through these processes. Edges where adjacent planes intersect are determined by several parametric primitives. We use three roof types, which are usually seen in urban areas, flat, gable and steeple. And multiple-layer roof of different heights is also considered and determined. Finally parameters of buildings are determined using 2D polygons and roof planes extracted at previous stage.

2. SEGMENTATION

To extract and reconstruct buildings, segmentation of points has to be done in advance of roof modelling. Generally ground points and buildings points are firstly separated from raw ALS data and then segmentation is conducted to classify points into different buildings. In some cases, additional process is required to group points of same building into several parts of different heights.

An algorithm to classify raw ALS points into the points which belong to the same buildings was proposed in our previous research (Han et al., 2007). The

suggested approach is partly similar to region growing and unsupervised classification. The first input point becomes the seed point of the first group. Then the next input point is compared with the points belonging to the first group. If they are adjacent and have similar height, the input point is classified to the first group, or else it becomes the seed point of a new group. In this way, input points become a member of one of the existing groups or the seed points of a new group. Using this segmentation algorithm, it is possible that by only one process raw ALS points are separated into different buildings and moreover points in one building are grouped into several parts of different heights. For the details of the segmentation algorithm we refer to (Han et al. 2007).

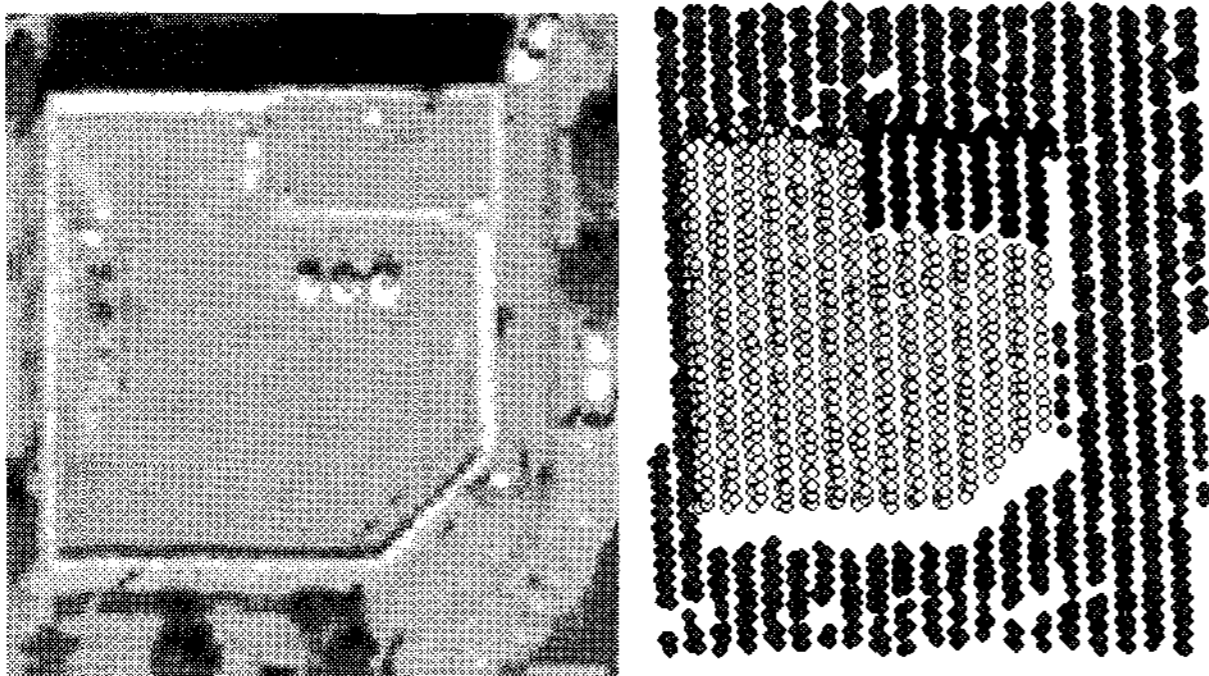

Figure 1. Segmentation Results of a building

It can be seen that building points separated from other points and also points with different heights in one building are segmented. In figure 1, green points and blue points indicate building and different colors of them mean different parts in a building. In the processes from this, different parts in one building will be dealt apart. And then in the final process of finding vertexes they will be considered to belong to one building and used together to find intersection points.

3. BOUNDARY EXTRACTION – STEP EDGE

From segmented points, building boundary and step edges are extracted by boundary refinement. It is conducted through three processes; boundary tracing, boundary generalization and boundary regularization. The algorithm is similar to our pervious research (Lee et al. 2006) except that not only building outlines but also step edges of parts of a building are extracted. Each process and the example of the extracted step edges are given below.

3.1 Boundary Tracing

To trace boundaries, the raw data points have to be segmented in advance. Because many researchers have been working on segmenting raw data points, we do not delve deeply into this topic. Thus, assuming that the data points have already been segmented, the trace begins with an analysis of the convex hull algorithm.

The convex hull algorithm determines the smallest convex set containing discrete points. However, many

buildings with a complicated shape are not convex. Applying the convex hull algorithm directly to these buildings cannot lead to an accurate determination of the shape of the building, nor can it contain all the boundary points.

Therefore, a modified version of the convex hull algorithm is proposed to overcome such problems. We restrict the search space of the convex hull algorithm to a shorter distance by constructing grids for the points in a building. For each grid cell to contain enough number of points, the grid size is set to double the mean distance between two points. Thus, the search space is restricted to the points in the current cell (i.e., that containing the previous detected boundary point) and the next cell.

3.2 Boundary generalization

After tracing the boundary, generalization is conducted to form groups of points belonging to each line segment. Because the edge lengths of buildings can vary, there are limitations in applying the conventional generalization algorithms directly to building boundaries. Therefore, we generalize boundaries using a two-stage procedure based on distance and angle. In the first stage, a conventional Douglas-Peucker algorithm based on orthogonal distance is used. In the second stage, by considering the peculiarity of buildings, we use the constraints of orthogonal distance, angle, and minimum length of edge. It is possible to further remove redundant points from the first corner points selected in the previous stage.

3.3 Boundary regularization

The objective of this step is to determine parametric lines and to find intersecting points of consecutive lines. This is known as regularization. The line segments are classified into one of three classes as they have right angles at their sides. If the angles on both sides of a line segment are far from to being a right angle, then the line segment is classified as Az_3 . If at least one angle is near to being a right angle, then the line segments are classified as Az_1 or Az_2 by applying unsupervised classification method using the azimuth values of the lines

, where θ_i = the azimuth of line segment l_i , θ_{r1} = the average azimuth of Az_1 , θ_{r2} = the average azimuth of Az_2 , and $\tan \theta_{r1} \times \tan \theta_{r2} = -1$:

$$\begin{cases} l_i \in Az_1 & \text{if } |\theta_i - \theta_{r1}| < |\theta_i - \theta_{r2}| \\ l_i \in Az_2 & \text{if } |\theta_i - \theta_{r1}| > |\theta_i - \theta_{r2}| \end{cases} \quad (1)$$

For line segments classified as Az_1 or Az_2 , the least squares method is conducted under the constraint of orthogonal conditions. The equations are given below, and all the unknown parameters in Eq. (2) are solved simultaneously:

$$\begin{cases} ax_{im} + by_{im} = c_i & \text{for } l \text{ of } Az_1 \\ ax_{jm} - by_{jm} = d_j & \text{for } l \text{ of } Az_2 \end{cases} \quad (2)$$

For line segments classified as Az_3 , the simple least squares method is applied individually to each line segments:

$$a_k x_{kl} + b_k y_{kl} = 1 \quad (k = 1, 2, \dots) \quad (3)$$

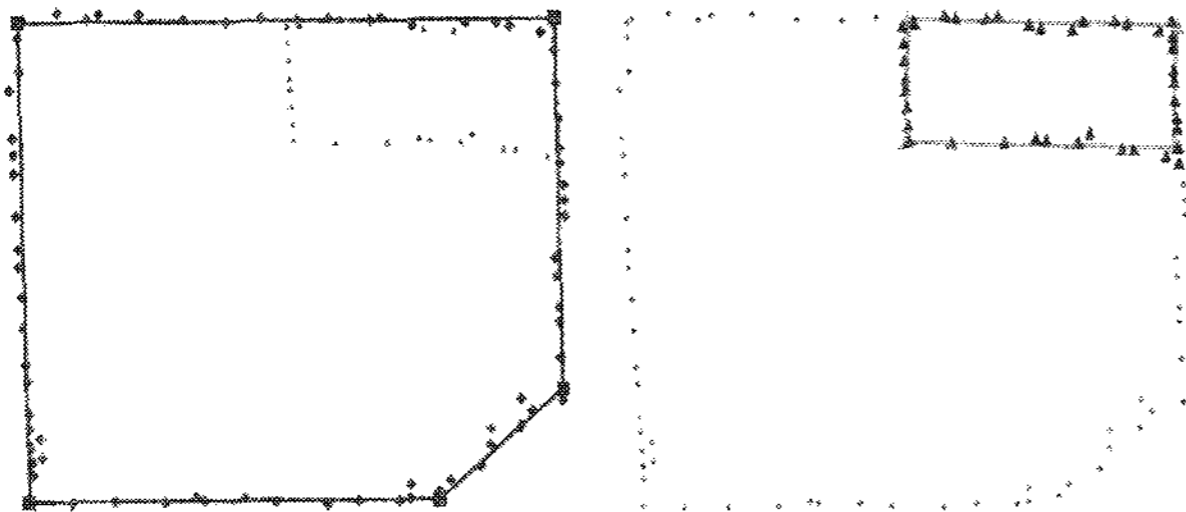

Figure 2. Extracted step edges (green and red lines)

With all the points in a building, set edge which is outline of the building is extracted (left of figure 2) and step edge of other parts is extracted with points belonging to only that parts (right of figure 2).

4. 3D BUILDING MODELING

4.1 Roof Modeling – Intersection Edge

To select roof types and find their parameters, roof points are grouped using 2D polygons determined previously. We here considered three parametric primitives of flat, gable, and steeple. Among these three models, the best fitting model and its parameters are determined by regression. Generally regression is performed about z values in 3D coordinate system. In this study, we used orthogonal distance fitting method to consider the errors of all directions.

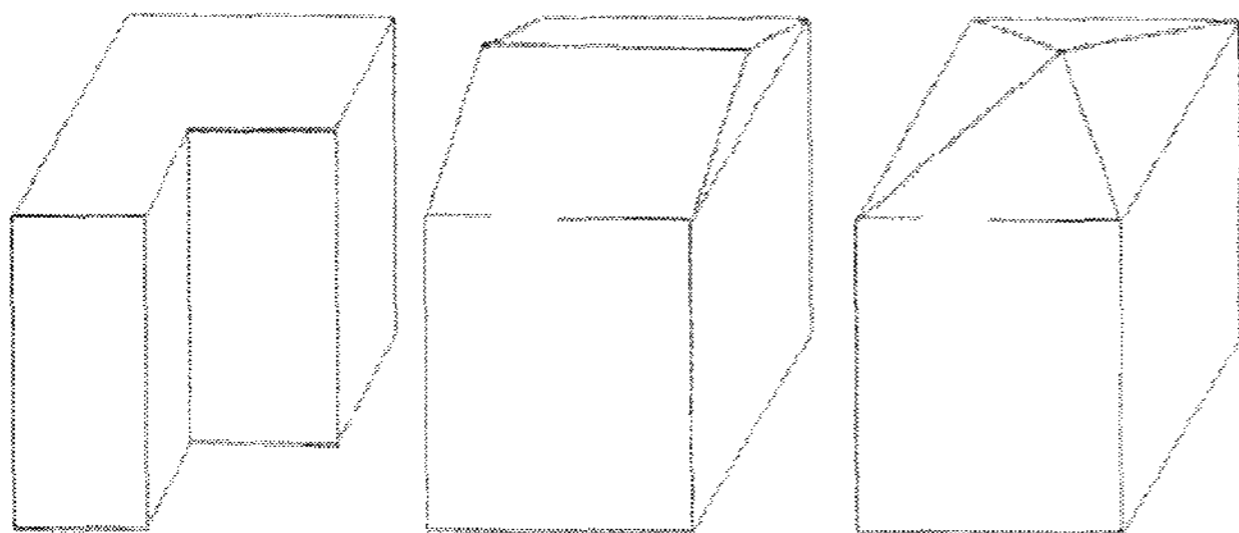

Figure 3. Roof types : flat, gable, and steeple

With all the points of a segment, a plane is determined which best fits the points. And then, the sum of errors, which is orthogonal distance from a point to the determined plane, is compared with threshold. An equation to calculate the sum of errors is as follows.

$$e = \sum \frac{|ax_i + by_i + cz_i + d|}{\sqrt{a^2 + b^2 + c^2}} \quad (4)$$

If the error is less than the threshold, the determined plane is accepted and the roof is considered to be flat, or else it is examined whether the roof is gable.

Points of a segment are classified into two groups by a line which is parallel with longer outline and goes through the centered point of the segment. For points of each group, orthogonal distance fitting method is applied to find planes. If the errors of orthogonal distance between points and the plane, the roof is considered to be gable, or else it is examined whether the roof is steeple.

In this case, points of a segment is classified into four groups by two lines connect the opposite angles. For points of each group best fitting plane is determined and the sum of errors is compared with threshold in the same way as described above.

As roof types are selected and also parameters of roofs are determined, the edges where adjacent planes intersect are extracted. Figure 4 shows an example of extracted intersection edges.

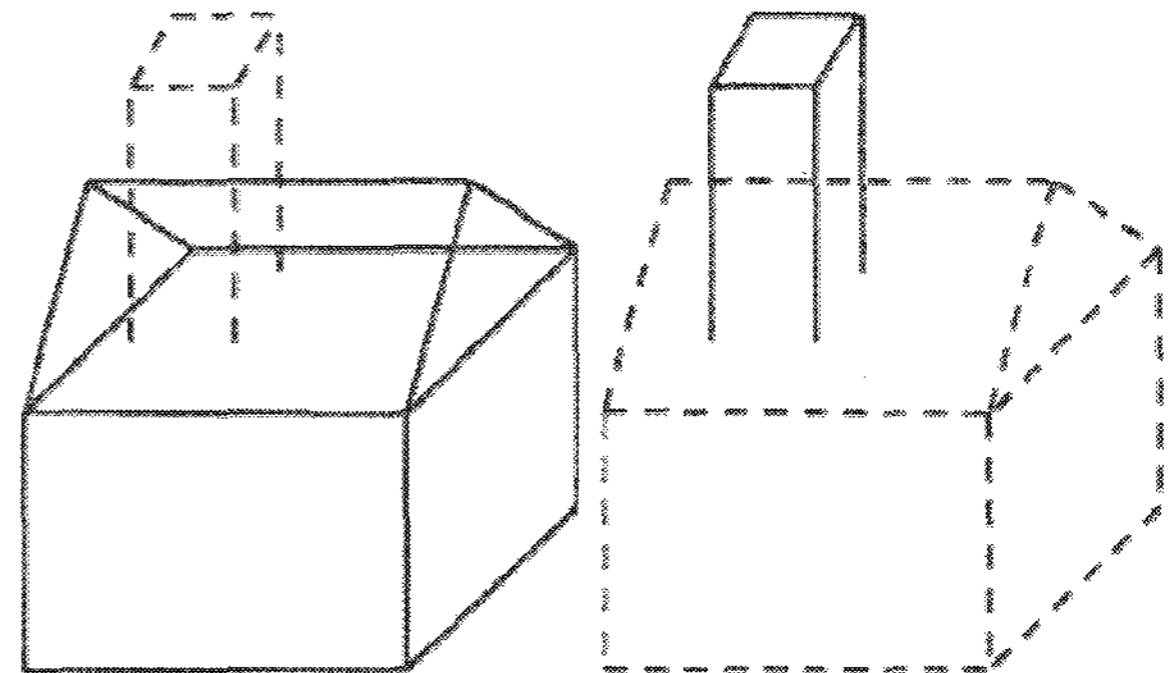

Figure 4. Roof types of parts of a building (left : gable, right : flat)

4.2 Finding Vertices

Now that we determine all step edges and intersection edges in a building, it is possible to make 3D model of the building. 3D modeling is conducted by finding vertices where planes and lines, or lines and lines intersect.

5. EXPERIMENTAL RESULTSTS

To apply our algorithm, we selected four buildings of different types which are common in urban areas. Non-rectangular shapes appear in these examples and buildings which consist of several parts of different heights are also contained. The final 3D models of some buildings are shown with their aerial photos in figure 5. An accuracy assessment was carried out by comparing the resulting 3D models with the aerial photos. From visual inspection, the reconstructed models show a reasonably good match to the photos.

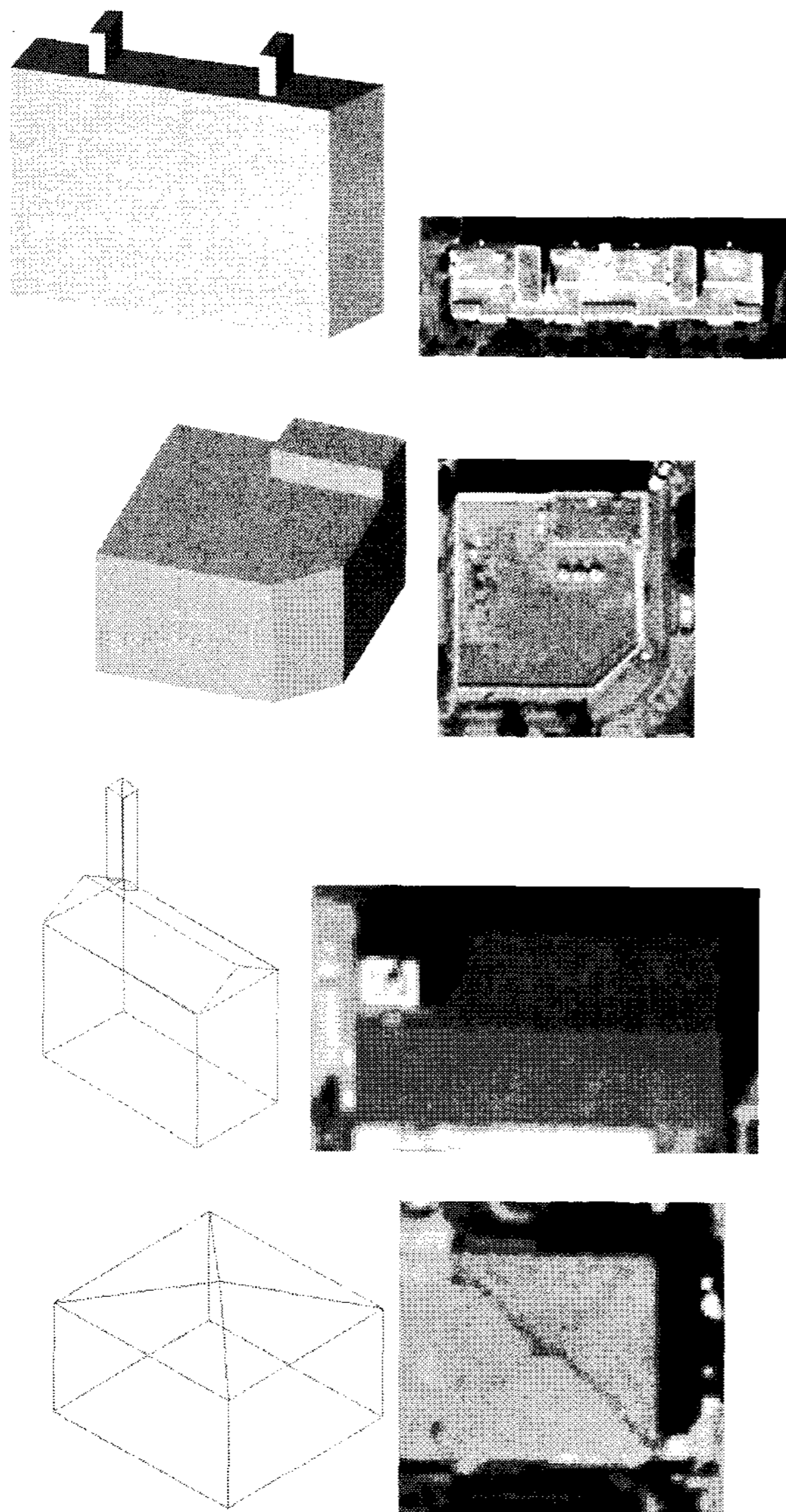

Figure 5. 3D model of some buildings

6. CONCLUSIONS

Raw ALS points were segmented into buildings and some parts of points with different heights in a building. From segmented points we extracted step edges of each part by boundary refinement and found roof types which best fits using orthogonal distance fitting method. Finally all vertexes were found where extracted lines and planes intersect. The results of the test for some buildings showed a good potential of reconstructing buildings only from ALS data. A future study will be focused on revising proposed algorithm to be applicable to buildings of more various shapes. And quantitative assessment of experimental results will have to be done so that our approach can be of practical use.

ACKNOWLEDGMENT

This research was supported by SNU SIR Group of the BK21 research Program funded by Ministry of Education & Human Resources Development.

References from Journals:

Alharthy, A., Bethel, J., 2002. Heuristic Filtering and 3D Feature Extraction from LiDAR Data. *ISPRS Commission III*, September 9-13, Graz, Austria.

Alharthy, A., Bethel, J., 2004. Detailed building reconstruction from airborne laser data using a moving surface method. *IAPRSIS XXXV - B3*, pp. 213-218

Brenner, C., 2000. Dreidimensionale Gebäuderekonstruktion aus digitalen Oberflächenmodellen und Grundrissen. PhD thesis, University of Stuttgart. DGK-C 530

Lee, J. H., Han, S. H., Byun, Y. G., Yu, K. Y., Kim, Y. I., 2006. Extraction and Regularization of Complex Building Boundaries from Segmented LiDAR Data. *WSEAS Transactions on Signal Processing*, 12(2), pp. 1544-1550

Rottensteiner, F., 2003. Automatic generation of high-quality building models from Lidar data. *IEEE CG&A* 23(6), pp. 42-51

Rottensteiner, F., Trinder, J., Clode, S. and Kubik, K., 2004. Fusing airborne laser scanner data and aerial imagery for the automatic extraction of buildings in densely built-up areas. *Proceedings of XXth ISPRS Congress, Commission 3, Istanbul, Turkey*, pp. 512

Vosselman, G., 1999. Building reconstruction using planar faces in very high density height data. *IAPRS XXXII/3-2W5*, pp. 87- 92