

New S-PVA Technology for Advanced LCD Performance

*Yoon Sung Um, Seung Beom Park, Hoon Kim, Hye Ran You, Jae jin Lyu,
Kyeong-Hyeon Kim and Sang Soo Kim*

L Development Center 1, LCD Business, SAMSUNG ELECTRONICS CO. LTD
San #200, Myeongam-Ri, Tangieong-Myeon, Asan-City, Chungcheongnam-Do, Korea
Phone: +82-41-535-5965
E-mail: yoonsung.um@samsung.com

Keywords : TFT-LCD, S-PVA , Wide viewing-angle

Abstract

A New S-PVA which is named as charge-shared super PVA (CS S-PVA) LCD mode is proposed. CS S-PVA controls the voltage ratio of low pixel by sharing system between low pixel and control cap, resulting in improved off-axis image quality and transmittance increase without any side effects. Moreover, the new S-PVA LCD mode is free of image-sticking. Operating schemes and display performance of CS S-PVA are presented.

1. Introduction

Patterned-ITO Vertical Alignment (PVA) technology has the advantage of providing wide viewing angle and high contrast ratio for various LCDs including applications like monitor, TV[1], [2], [3]. Samsung proposed super-PVA (S-PVA) technology to further improve viewing angle and contrast ratio. Until now, two types of S-PVA have been developed: Capacitively-coupled (CC) S-PVA, and two-transistor (TT) S-PVA [4], [5]. S-PVA technologies have overcome the limitations of PVA and have become the most suitable solution to meet the demands for large-area flat panel TVs. In spite of their superior performance, CC and TT S-PVA face some challenges. CC S-PVA has the advantage of pixel structural and driving simplicity, but can suffer from image sticking and imperfect off-axis image quality. TT S-PVA LCD solves these problems, and is so effective for wide angle of view performance that off-axis image degradation is barely detectable [6], [7]. However, TT S-PVA requires either data multiplexing or else twice as many driver ICs. In this paper, a new S-PVA (CS S-PVA) technology is proposed. CS S-PVA, like CC S-PVA, can utilize 1G-

1D driving, which in turn offers high charging time margin for high frame rate driving. Moreover, CS S-PVA improves off-axis image quality and transmittance to a level comparable to TT S-PVA, thereby providing an advantage over existing CC S-PVA technologies.

2. Results

2.1 Viewing angle expansion and limitations of CC S-PVA

The viewing angle of PVA mode LCDs can be expanded by modulating liquid crystal (LC) directors according to different regions, also referred to as sub-pixels, in one pixel. To achieve this, each pixel is divided into multiple sub-pixels, and different voltages are applied to each sub-pixel. S-PVA has two such regions called the A and B sub-pixels. At the mid-gray levels, a higher voltage is applied to the A sub-pixel creating a higher gamma curve, and a lower voltage is applied to the B sub-pixel creating a lower gamma curve. TT S-PVA uses two separate TFTs for individual control of each sub-pixel, while CC S-PVA uses a capacitively coupled structure to create different sub-pixel voltages. Therefore conventional 1G-1D driving can be used for CC S-PVA. With this structure, CC S-PVA can achieve improved off-axis image quality compared to conventional PVA mode. However, the image quality of CC S-PVA is not as good as that of TT S-PVA. The main reason is that in CC S-PVA each sub-pixel voltage cannot be independently controlled, whereas sub-pixel voltage independence is easily achieved with TT S-PVA. Also, due to the capacitive divider, the B sub-pixel cannot be turned on completely. As a result, CC S-PVA has lower transmittance and inferior off-axis image quality compared to TT S-PVA.

2.2 Improvement of transmittance and off-axis image quality

CS S-PVA resembles the CC S-PVA pixel structure at a glance, yet it has a very different operating principle. The additional two capacitors serially linked to the A sub-pixel are connected to the B sub-pixel through a transistor (Figure 1).

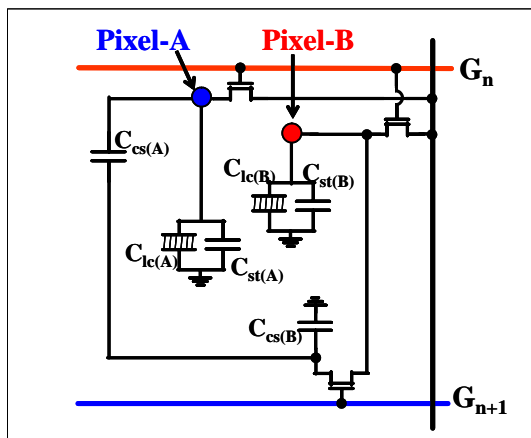

Figure 1. Equivalent circuit for CS S-PVA pixel structure [$C_{cs(A)} = 0\% \sim 40\%$ of $C_{lc(A)}$]
[$C_{cs(B)} = 10\% \sim 50\%$ of $C_{lc(B)}$]

When the N^{th} gate is turned on, the two sub-pixels have same pixel voltage. In inverse proportion to each capacitor size, the pixel voltage gets distributed to the two capacitors, $C_{cs(A)}$ and $C_{cs(B)}$ which are serially linked to sub-pixel A. When the next $(N+1)$ gate line is turned on, the node between $C_{cs(A)}$ and $C_{cs(B)}$ is connected to the B sub-pixel electrode. As a result, $C_{cs(A)}$ charges sub-pixel A and the voltage level of sub-pixel A increases. Therefore the A sub-pixel becomes brighter. Conversely, $C_{cs(B)}$ takes some charge from sub-pixel B to a voltage level between $C_{cs(B)}$ and sub-pixel B, causing the B sub-pixel to become darker.

In this manner the pixel-voltage difference between two sub-pixels can be controlled by the two charge-sharing capacitors, $C_{cs(A)}$ and $C_{cs(B)}$. Individual gamma curves for the A and B sub-pixels are controlled by charge-sharing capacitors such that their luminance sum achieves the target gamma value. The additional capacitors and transistor improve the individual voltage driving to each sub-pixel. Sub pixel B'cap is variable but $C_{cs(B)}$ is constant at all grays so $C_{cs(B)}$ takes constant charge from Sub pixel B. Due to this characteristic CS-SPVA resembles TT-SPVA' characteristics.

Improved voltage driving for each sub-pixel reduces gamma-distortion off-axis, resulting in

enhanced angle of view performance. Peak luminance is also increased relative to CC S-PVA because both sub-pixels can achieve a larger voltage ratio at maximum grey. Figure 2 and Figure 3 shows the increased voltage ratio of the two sub-pixels in CS S-PVA mode, which results in transmittance increase. As a result, CS S-PVA exhibits 10% transmittance improvement over CC S-PVA

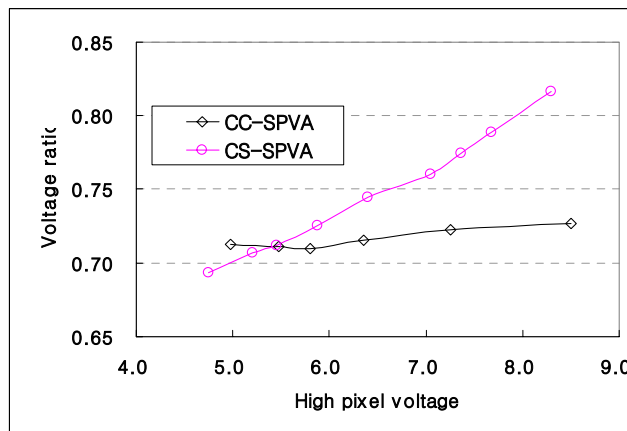

Figure 2. CC and CS S-PVA sub-pixel voltage ratio comparison

Figure 3 shows the off-axis gamma improvement of CS S-PVA mode. As shown in Figure 3, the off-axis gamma curve for CS S-PVA is much closer to the on-axis curve compared to CC S-PVA. This comparison shows that CS S-PVA has significantly reduced off-axis gamma distortion, resulting in minimal deterioration of color and contrast ratio.

To make a quantitative comparison, we use the off-axis image distortion index [$D(\theta, \varphi)$] as

$$D(\theta, \varphi) = \left\langle \frac{|\Delta B_{i,j(\text{on-axis})} - \Delta B_{i,j(\text{off-axis}, \theta, \varphi)}|}{\Delta B_{i,j(\text{on-axis})}} \right\rangle_{i,j=0-255},$$

where $\Delta B_{i,j}$ is brightness difference between gray- i and gray- j , and $\langle \rangle$ is the global average for all possible combinations of gray- i and gray- j . $D(\theta, \varphi)$ can range from 0 to 1. A smaller value means smaller image distortion, that is, better off-axis image quality. At the $(60^\circ, 0^\circ)$ viewing position, CS S-PVA has a D value about 0.20, much smaller than 0.24 which is typical for CC S-PVA monitor.

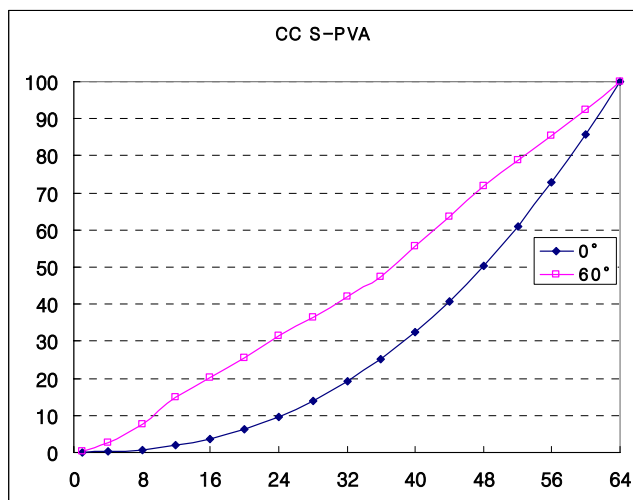

(a)

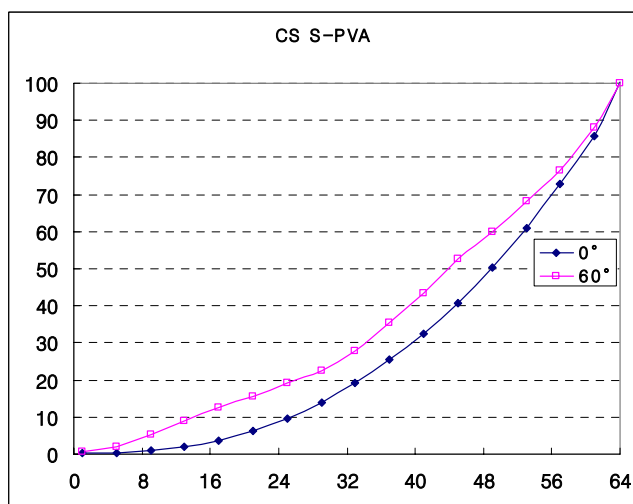

(b)

Figure 3. Off-axis gamma comparison of (a) CC S-PVA and (b) CS S-PVA

2.3 Influence of new pixel structure on image sticking reduction

Image sticking is a condition wherein, after a long period of displaying the same image, a ghost image remains when the display signal is then changed. It is commonly understood that the residual DC voltage is related to image sticking. It has recently been proposed that residual DC voltage of the LCs on the floating electrode layers of CC S-PVA is a possible cause of image sticking. This, however, has not yet been proven experimentally.

In this research, the image-sticking property of CC S-PVA with residual DC voltage on a floating electrode surface was studied. The residual DC voltage was measured indirectly from the voltage shift on the

floating sub-pixel electrode of CC S-PVA. It was found that the residual DC increased after a long period of displaying of static pattern images in CC S-PVA LCDs.

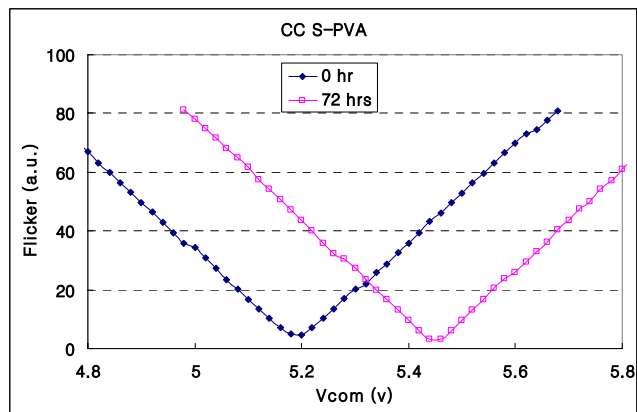

(a)

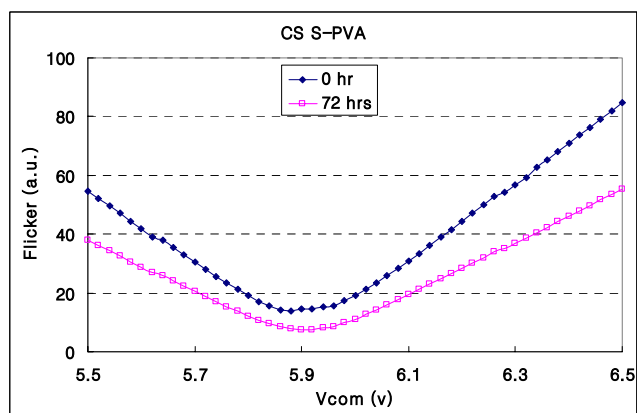

(b)

Figure 4. Comparison of the optimum common-electrode voltage shifts after 72 hours of displaying a static pattern on LCD screen. (a) CC S-PVA and (b) CS S-PVA

We measured median pixel-voltage shifts on the B sub-pixel over time. We found that the optimum common-electrode voltages at which the flicker level could be minimized shifted over time. The pixel voltage shift was significant in CC S-PVA, but the shift did not occur in CS S-PVA. As shown in figure 4, after 72 hours of displaying a static pattern, the optimum common-electrode voltage shifted in CC S-PVA by about 1.26V. But in the case of CS S-PVA, the shift was minimal. This indicates that removing floating electrodes from the pixel structures helps to reduce residual DC, which may improve image sticking properties in our new CS S-PVA LCD panels.

2.4 Self over-driving effect of new pixel structure

CS-SPVA has self over-driving effect, and its effect depends on ΔV between grays. The effect comes mainly from sub pixel B. Figure 5 shows the effect of self over-driving effect without any over driving circuit, but its response characteristic is almost the same as using over-driving circuit. We can notice over-shoot effect at Figure 5 (b). G to G response of VA mode is relatively slower to "In plane switching mode" like IPS or FFS, CS-SPVA can overcome G to G disadvantage with self overdriving effect of CS-SPVA

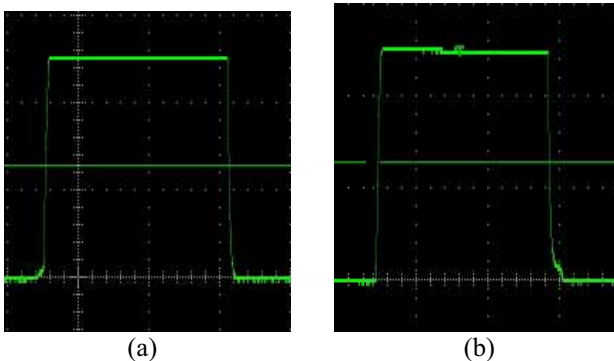

Figure 5. Comparison of the response of CS-SPVA
a) With overdriving circuit (b) Without overdriving circuit

3. Summary

A new SPVA(CS-type S-PVA) has been developed to advance current S-PVA technologies for improved LCD quality using a simplified driving scheme. CS S-PVA enables S-PVA to adopt 1G-1D driving and has the potential for low production cost. Moreover, by introducing charge-sharing capacitors in combination with additional transistors, CS S-PVA achieves a 10% increase in transmittance and better angle of view performance.

Image sticking has been a challenge for achieving maximum productivity with CC S-PVA. Comparison of optimum common-electrode voltage shifts has shown that removing floating electrodes from the pixel structure could be key to delivering image sticking free performance.

CS-SPVA has also self over-driving effect which comes from sub pixel B like CC-SPVA.

4. References

- [1] K. H. Kim, K. Lee, S. B. Park, J. K. Song, S. Kim, J. H. Souk, "Domain Divided Vertical Alignment Mode with Optimized Fringe Field Effect", Proceedings of Asia Display 98, pp. 383-386, 1998
- [2] K. H. Kim, J. H. Souk, "Patterned Vertical Alignment (PVA) Mode for High Performance LCD Monitors", Proceeding of Euro-display 99, pp. 115-119, 1999
- [3] K. H. Kim, S. S. Kim, "Invited Paper: Advance of PVA Technology for Multi-media Applications", SID Symposium Digest, pp.1208-1211, 2003
- [4] S. S. Kim, "Invited Paper: Super PVA Sets New State-of-the-Art for LCD-TV", SID Symposium Digest, pp. 760-763, 2004
- [5] S. S. Kim, "Invited Paper: The World's Largest (82-in.) TFT-LCD," SID Symposium Digest, Vol. 36. pp. 1842-1847, 2005
- [6] S. S. Kim, B. H. Berkeley, J. H. Park, T. S. Kim, "New Era for TFT-LCD Size and Viewing Angle Performance", Journal of the SID, Vol. 14, Number 2, 2006
- [7] S. S. Kim, K. H. Kim, B. H. Berkeley, T. Kim, "Invited Paper: Super-PVA Technology for High-End TV Applications", Proceedings of 26th IDRC, pp. 154-158, 2006