

## External Electrode Fluorescent Lamp Model Based on the Equivalent Resistance and Capacitance Variation

*Kyu-Min Cho\**, *Won-Sik Oh\**, *Gun-Woo Moon\**,  
*Mun-Soo Park\*\**, *Sang-Gil Lee\*\**, *Min-Gyu Kim\*\**

**\*Display Research Center, Korea Advanced Institute of Science and Technology  
373-1 Guseong-Dong, Yuseong-Gu Daejeon, 305-701**

**\*\*Samsung Electronics Co., Ltd**

**Phone: +82-42-869-8528, E-mail: negative@angel.kaist.ac.kr**

### Abstract

*A circuit model simulating the electrical characteristics of EEFL(External Electrode Fluorescent Lamp) is proposed. The model is based on linear approximation that represents the equivalent resistance and capacitance as a function of power. Simulation waveforms and experimental results are presented to verify feasibility of the equivalent model.*

### 1. Introduction

The electron display devices play an important role as an information display for a man-to-machine interface. With the rapid progress in the information industry, there has been a continuous increase in the demand for new electronic display devices with a large size, high resolution, and high information capacity. Generally, display devices are divided into two classes as shown in Fig 1. Non-flat panel display such as a cathode ray tube(CRT) and flat panel display(FPD) such as a liquid crystal display(LCD), plasma display panel(PDP), electro luminescent display(ELD), field emission display(FED) and so on. LCD among these devices has light weight, low profile, high resolution, low power consumption, etc. Therefore it has superior advantage to other display device below 50-inch.

Since LCD panel itself can not emit light, the backlight source that supplies the light from behind is required. So far, CCFL called a cold cathode fluorescent lamp is commonly used. It does not require preheating of the filament and the electrodes at the end of the bulb stay at the low temperature while emitting light unlike HCFL (Hot Cathode Fluorescent Lamp). But as the demand of large LCD panel for digital TV is

increasing, many drawbacks appear in CCFL. The main drawback is the oxidation of the internal electrode due to the collision of gas particle. It induces a short life in CCFL. It must also have ballast capacitor due to negative resistive characteristics. Moreover it has unbalancing current in parallel driving with one inverter. If the size of LCD panel is large, the corresponding inverter and ballast capacitors are needed. (about 20~40 CCFLs in 32-inch LCD TV). To overcome this problem, recently EEFL with external electrode has been suggested. Thank to the structure without internal electrode, the EEFL has longer lifetime, higher power efficiency and higher luminance than CCFL. Moreover a small capacitance by external electrode helps EEFL to operate in parallel like a ballast capacitor. Therefore EEFL is expected quickly to substitutes CCFL in backlight system. But the equivalent circuit model of EEFL has not been investigated until now. The equivalent circuit model is a useful tool to verify the performance of the backlight inverter as zero voltage switching condition, conduction loss, voltage/current stress of active components.

This paper presents equivalent circuit model of EEFL based on a linear approximation that represents the equivalent resistance and capacitance as function of power. Modeling method and numerical equation is presented. Simulation data and experimental results are compared at the end of this paper to verify the feasibility of the proposed model.

### 2. Equivalent Circuit Model

Fig 1 shows structure and equivalent circuit model of CCFL and EEFL. To have long life time,

EEFL has two external electrodes which are capsulated at the both ends of the lamp. When the square wave sustain voltage is applied to EEFL, gas discharge occurs in the lamp. Because there is no internal electrode, exciting gas particles (ions, electrons,...) are accumulated at the ends of the lamp. They are called wall charges, which limit the discharge current. Therefore two external electrodes operate as a capacitor. And gas plasma has electrically high conductive characteristic, which operates as a resistor. Therefore we can assume that EEFL electrically has one resistive and two capacitive components shown in Fig 1 (b).

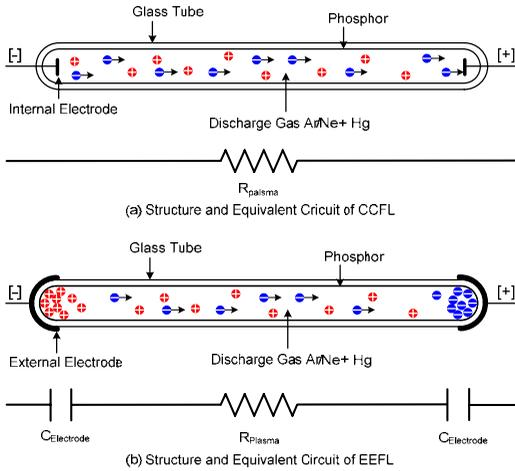

**Fig 1. Structure and Equivalent Circuit of Lamp**  
(a) CCFL (b) EEFL

Fig 2 shows half bridge series resonant inverter for driving EEFL and equivalent circuit of that. Llkg is leakage inductor of transformer. Impedance of EEFL is represented as

$$Z_{Lamp} = Z_r + iZ_i = R_{Plasma} - i \frac{1}{\pi f \times C_{Electrode}}$$

$$= R_s - i \frac{1}{2\pi f \times C_s}$$

(1)

To find the value of Rs and Cs, we should measure rms current of lamp (ILamp,rms), rms voltage of lamp (VLamp,rms) and lamp power (PLamp). From achieved data, Rs and Cs can be calculated by equation (2),(3).

$$R_s = \frac{\frac{1}{T} \int_0^T (V_{Lamp} \times I_{Lamp}) dt}{I_{Lamp,rms}^2} = \frac{P_{Lamp}}{I_{Lamp,rms}^2} \quad (2)$$

$$C_s = \frac{1}{2\pi f_s \sqrt{\left(\frac{V_{Lamp,rms}}{I_{Lamp,rms}}\right)^2 - R^2}} \quad (3)$$

Experimental data were obtained through a LeCroy WaveSuffer 434, employing a half bridge series resonant inverter according Fig 2. The data were acquired to several power levels from 40 watts to 120 watts, and to several switching frequency from 50kHz to 100kHz. The power variation was achieved through the line voltage control maintaining full discharge.

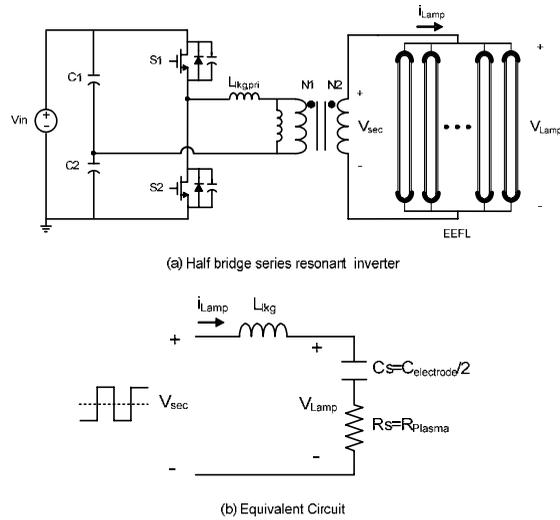

**Fig 2. (a) Half bridge series resonant inverter**  
(b) Equivalent circuit

The value of Rs and Cs is represented in Fig 3. In all driving frequency, Rs becomes smaller and Cs becomes larger as lamp power increases. Physically, the variation of resistance means increase of conductivity in plasma due to increase of the plasma particle. The change of capacitance means decrease of Debye length between external electrode and gas plasma.

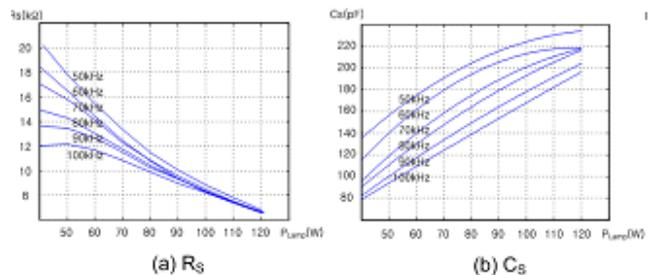

**Fig 3. (a) Experimental data of Rs**  
(b) Experiment data of Cs

These curves can be expressed function of lamp power using linear approximation. Rs and Cs are expressed as equation (4),(5). Each coefficient are listed in Table I.

$$R_S(P_{Lamp}) = a_R P_{Lamp}^2 + b_R P_{Lamp} + c_R \quad (4)$$

$$C_S(P_{Lamp}) = a_C P_{Lamp}^2 + b_C P_{Lamp} + c_C \quad (5)$$

**Table I**

Coefficient of Rs			
fs	a <sub>R</sub> (10 <sup>0</sup> )	b <sub>R</sub> (10 <sup>2</sup> )	c <sub>R</sub> (10 <sup>4</sup> )
50kHz	1.3313	-3.8270	3.3677
60kHz	1.0979	-3.2555	2.9882
70kHz	0.6505	-2.3852	2.5870
80kHz	0.1664	-1.3694	2.0458
90kHz	-0.1305	-0.7436	1.7235
100kHz	-0.3564	-0.1716	1.3661
Coefficient of Cs			
fs	a <sub>C</sub> (10 <sup>-14</sup> )	b <sub>C</sub> (10 <sup>-12</sup> )	c <sub>C</sub> (10 <sup>-11</sup> )
50kHz	-1.2378	3.2179	2.6220
60kHz	-1.7202	4.0478	-1.9542
70kHz	-1.1487	3.3689	-2.1113
80kHz	-0.6816	2.6731	-6.1190
90kHz	-0.3939	2.1569	1.9706
100kHz	-0.0888	1.6159	1.5282

Fig 4 shows experimental data and an approximation using equation (4),(5) in 50kHz. We could know approximation coincident with experimental data.

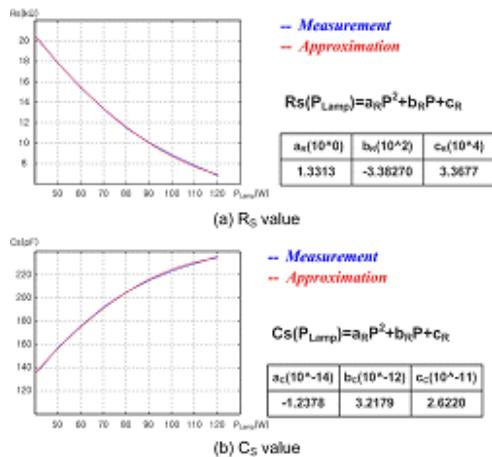

**Fig 4. (a)  $R_S$  versus lamp power  
(b)  $C_S$  versus lamp power**

Fig 6. shows the block diagram of EEFL equivalent circuit model for simulation. The block

diagram is composed by three parts which are power calculation part, equivalent  $R_S$  part, and equivalent  $C_S$  part.

In power calculation part, the instantaneous lamp power  $P_{inst}$  (6) is first obtained multiplying the lamp voltage by lamp current. The lamp power  $P_{Lamp}$  (7) is calculated by averaging instantaneous lamp power.

$$P_{inst}(t) = V_{Lamp}(t) \times I_{Lamp}(t) \quad (6)$$

$$P_{Lamp} = \frac{1}{T} \int P_{inst}(t) dt \quad (7)$$

In equivalent  $R_S$  part, the value of  $R_S$  could be calculated using equation (4) and  $P_{Lamp}$ . The circuit diagram with resistor and dependent voltage source is made to satisfy equation (8).

$$V(R_S) = 1 \times I_{Lamp} + I_{Lamp} \times R_S(P_{Lamp}) - I_{Lamp} = I_{Lamp} \times R_S(P_{Lamp}) \quad (8)$$

In equivalent  $C_S$  part, the value of  $C_S$  could be calculated using equation (5) and  $P_{Lamp}$ . The circuit diagram with capacitor and dependent voltage source is made to satisfy equation (9).

$$V(C_S) = \frac{1}{C_S(P_{Lamp})} \int I_{Lamp}(t) dt \quad (9)$$

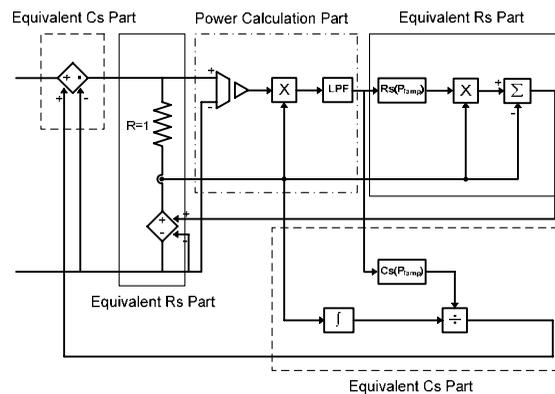
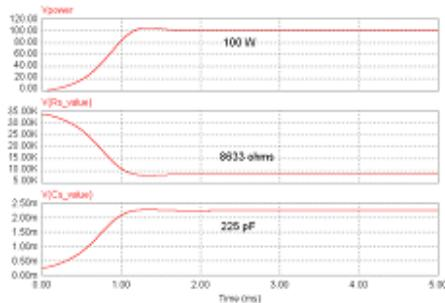

**Fig 5. Block diagram of EEFL equivalent circuit model**

### 3. Simulation and Experimental Results

The simulation results of EEFL equivalent circuit model are shown in Fig 6. The specification for simulation is as same as Table I. Lamp power is obtained to averaging instantaneous lamp power. The value of equivalent resistance and capacitance

is calculated exactly same to experimental data by using lamp power. In Fig 7 shows simulation and experimental waveforms in 80watts and 100 watts. We could know simulation waveforms coincide with experimental results very well.



**Fig 6. Simulation results :**  
Lamp power, Rs value, Cs value

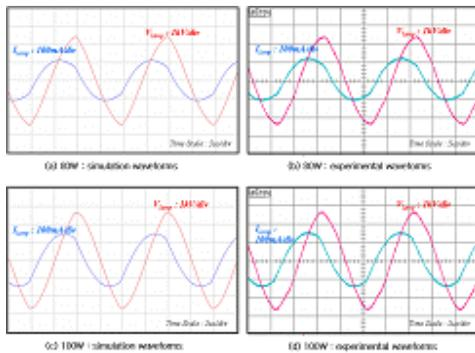

**Fig 7. Current and voltage waveform**  
(a) simulated (b) experimental ( 80 watts )  
(c) simulated (d) experimental ( 100 watts )

#### 4. Conclusion

EEFL with external electrode has many merits compared to CCFL. It seems to be widely used as LCD backlight source. Therefore equivalent circuit modeling of EEFL will be very useful to design LCD backlight system.

Analyzing the simulations, we could conclude that the simulation waveforms are according to the experimental results, Therefore the proposed model becomes a useful tool in design of backlight inverter.

#### 5. Acknowledgements

This work was supported by Samsung LCD Business, Korea, under Display Research Center Program.

#### 6. References

- [1] T. S. Cho : ‘Capacitive coupled electrodeless discharge backlight driven by square pulses’, IEEE Transactions on Plasma Science, Vol. 30, No.5, October 2002.
- [2] N. O. Kwon : ‘Self-discharge synchronizing operations in the external electrode fluorescent multi-lamps backlight’, Asia Display/IDW’01, Proceedings, Nagyoya, Japan, pp625-628
- [3] U. Mader : ‘a Dynamic model for the electrical characteristics of fluorescent lamps’, IEEE-IAS’92, Anais, pp1928-1934
- [4] G. S. Cho : ‘Glow discharge in the external electrode fluorescent lamp’, IEEE Transactions on Plasma Science, Vol.33, No.4, August 2005
- [5] C. G. Kim : ‘Driving cold cathode fluorescent lamps in parallel’, IEE Electronics Letter, Vol41, No.4, February 2005
- [6] R. N. Prado : ‘Fluorescent lamp model employing tangent approximation’, IEEE-ISA’01 Annual Meeting Records
- [7] T. F. Wu : ‘A PSpice model for fluorescent lamps operated at high frequencies’, IEEE IECON’95 Proceedings, Vol.1, pp. 359-364, 1995