

# Modeling of Superficial Pain using ANNs

Nobutomo MATSUNAGA\*, Asayo KUROKI and Shigeyasu KAWAJI\*

\*Department of Computer Science, Kumamoto University, 2-39-1 Kurokami, Kumamoto 860-8555, Japan  
(Tel : +81-96-342-3639 ; Email : matunaga@st.cs.kumamoto-u.ac.jp, kawaji@cs.kumamoto-u.ac.jp)

**Abstract:** In the environment where human coexists with robot, the problem of safety is very important. But it is difficult to separate the robot from the human in time-domain or space-domain unlike the case of factory automation, so a new concept is needed. One approach is to notice sensory and emotional feeling of human, and in this study "pain" is focused, which is a typical unpleasant feeling when the robot contacts us. In this paper, to design the controller based on the pain, an artificial superficial pain model caused by impact is proposed. This ASPM model consists of mechanical pain model, skin model and gate control by artificial neural networks (ANNs). The proposed ASPM is evaluated by experiments.

**Keywords:** Pain model, Gate control theory, Artificial neural networks, Safety system

## 1. INTRODUCTION

Safety concept has been usually progressed in factory automation fields, and safety categories are defined in international organization for standardization (ISO). The concept and principle of basic safety is to separate the human from machine in the sense of space and time. However, according to the advance of robot into home space, it will be difficult to separate them.

Therefore, a new concept of separation of robots and human will be required in their coexistence. Most conservation approach to realize the safety coexistence circumstance is to make the physical regulations to the output power, working velocity, size or weight of robots and so on. Some studies have been investigated to make the criterion based on somatic pain. However these had focused on upper limit based on the pain tolerance [1],[2],[3] or safety equipments for robot[4], and there have been no discussion about the dynamic model of pain.

In international association for the study of pain (IASP), pain is defined as "An unpleasant sensory and emotional experience associated with actual or potential tissue damage, or described in terms of such damage". From the view point of neurotransmission of pain, mathematical modeling of the pain has been tried in molecular biology [8], and focused on the ion receptors and ion generation. Pain model using artificial neural networks (ANNs) has been studied in neurophysiology [7] without experiments and application aspects. From the view point of industrial applications, controllers are designed based on the physical variables, e.g. impact or static force. However, there have been no studies using pain that is subjective feeling. It is well known that the human learning ability of human is improved by causal linkage between action and subjective feeling, e.g. pain and pleasure. Therefore, embedding subjective feeling into robot controller is highly significant from the subjective of realization of an advanced learning system. Also, from the view point of safety system design, it will be key of the new safety index to make robot realize the essence of subjective pain in coexisting environment with human and robot.

Our study aims at realization of safety robot and machine

embedded the pain model and its application to anthropomorphic machine. As most of the pain caused by physical interaction between robots and humans is the superficial pain caused by impact damage, we focus on the superficial pain in this paper. Artificial superficial pain model (ASPM) caused by impact is proposed. Based on features of the superficial pain, ASPM is constructed by three blocks; mechanical pain model using two mass system, skin model using elastic model and ANNs based on gate control theory.

## 2. EXPERIMENTS OF SUPERFICIAL PAIN

Superficial pain caused by impact damage is quantified by simple experiment. In the experimental system shown in Fig.1. The weight is made to fall freely on the fingertip. The experimental conditions are shown in Table.1.

Table 1. Experimental Conditions

Point of stimulation	middle finger, right hand
Weight	0.45kg
Free fall displacement	70mm
Contact area	0.85mm <sup>2</sup>
Maximum impact force	150N

It is pointed out [8] that measurement data of pain has susceptibility to the influence of emotional modification, and remove of emotional modification from the sensory stimulus is difficult. Therefore, it is required to announce for the subjects to keep the algetic level and relax without muscle tone. The subjective pain level is recorded by modified visual analog scale method (VAS) [5]. In the following, experimental results are compared with two subjects (20 ages, male). First, in order to quantify the sensation of pressure, the sensation caused by intensity of pressure is formulated. The sensation of pressure is expressed by Steven's power function [5],

$$I = k(S - S_0)^n \tag{1}$$

where  $I$ ,  $S$  and  $S_0$  indicate the sensation intensity, pressure level and threshold, respectively.  $k$  and  $n$  are the proportional and power series parameters depending on the peoples.

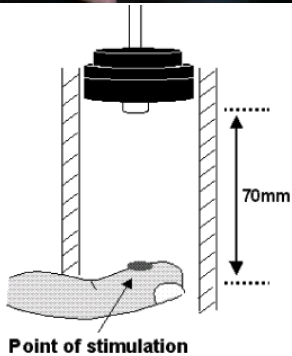
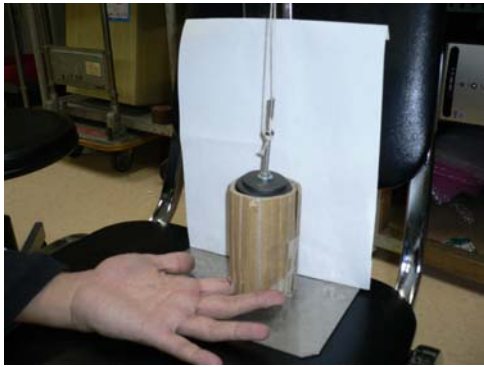

Fig. 1. Experiment for pain measurement

Fig.2 and Fig.3 show the relationship between the intensity of pressure and sensation of pressure. From these figures, the parameters of Steven's power function are different not only in peoples but also on trials. And subject B is more sensitive than subject A in terms of pressure sensation.

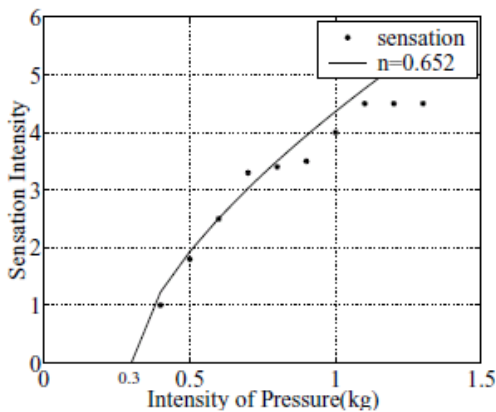

Fig. 2. Sensation of pressure (Subject A)

Secondly, the subjective pain level is measured by contact sensor. Note that some training of the contact sensor presser and the max pain is carefully memorized so as to indicate the correct level before experiments. The range of pain level is set as 0 to 10 for quantification. As pain is generally subjective sensation, not only experimental conditions but also personal difference of subjective sensation should be considered [8]. Experimental results for subject A and B are shown in Fig.4 and 5, respectively.

From these figures, it is obvious that there are two peaks in

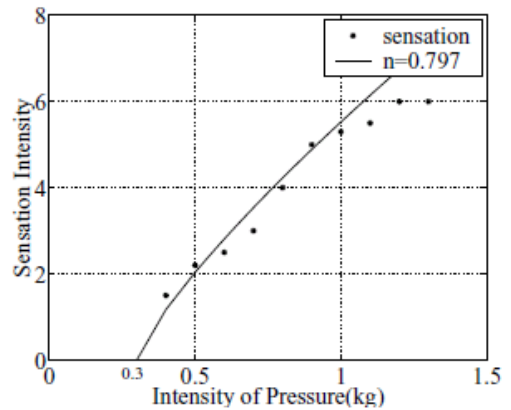

Fig. 3. Sensation of pressure (Subject B)

response of pain. First peak of pain indicates the fast pain detected on the skin surface, and second one indicates the slow pain detected in the deep area of the fingertip. It is observed that fast peak can be detected at the impact damage and the level is normalized as maximum, but the amplitude and the timing of the second peak are depending on subjects. Also, pain durations of two subjects are almost 45[s] after impact damage. Table 2 summarized the parameters of pain comparing two subjects where stimulation is applied three times for every person. Second peak level and time of the pain is depending on the personality.

Table 2. Variance of pain characteristics

characteriscs	Subject A	Subject B
First pain level	$9.8 \pm 0.1$	$9.8 \pm 0.1$
Second pain time	17 ~ 22[s]	19 ~ 20[s]
Second pain level	$6 \pm 2$	$6 \pm 0.5$
Pain duration	43 ~ 50[s]	43 ~ 49[s]

It is summarized that the superficial pain has three features; twin peaks, level and timing of 2nd peak depends on personal sensation and the pain lasts for a while depending on the magnitude of impact damage.

### 3. GATE CONTROL THEORY

The neurotransmission of pain has been studied in medical science, and the details has not cleared yet. But, gate control theory was proposed by Melzack and Wall in 1965 [5]. The concept of gate control theory is simple, and conduction of pain is expressed as a simple model as shown in Fig.6.

It is well known [8] that stimulus in peripheral nerve is translated via two afferent paths, i.e. large nerve fiber(L fiber) and small nerve fiber(S fiber) to nerve center. Stimulus from L fiber restrains the pain from S fiber so as to lessen the pain. In vivo response to head banging, it is observed that pain is lessened in case of stroke the skin around damaged point because the L fiber is activated by stroke signal.

In Fig.6, activation of SG and T cells can be expressed as follows.

1. In case that strong stimulation is added on the skin,

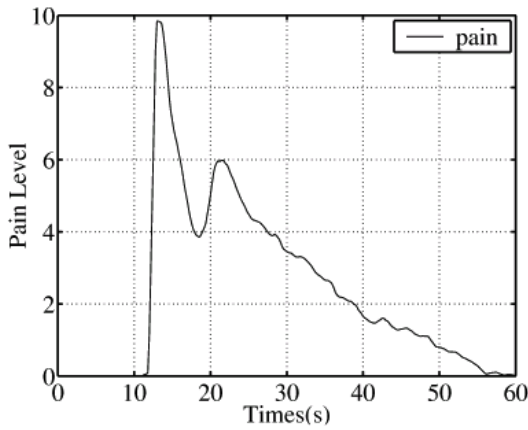

Fig. 4. Measured pain level (Subject A)

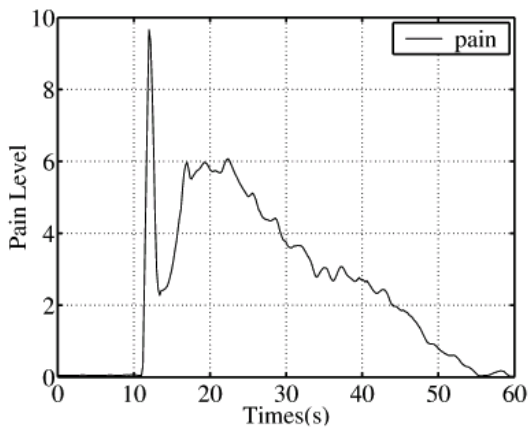

Fig. 5. Measured pain level (Subject B)

impulse from S fiber excites the T cell. Gate of S fiber is opened so as to lessen the activation of SG neuron. As a result, pain signal to T cell is increased.

- In case that the weak stimulation, i.e. touch signal, is added in peripheral nerve, gate of S fiber is closed and impulse from L fiber is opened because impulse from L fiber excites the T cell and SG neuron simultaneously. Impulse from L fiber translated to cerebral cortex via dorsal column of spinal code. After then impulse modified emotionally by affect, recognition, think, memory, circumstantial judgment and so on, is translated from cerebral cortex to spinal dorsal horn, and gate of S fiber is closed.

Consequently, control cells concerned with pain is activated in case that the impulse level to T cell exceeds the critical level.

#### 4. ARTIFICIAL SURFICIAL PAIN MODEL (ASPM)

In this section, we will propose a new artificial superficial pain model (ASPM) using the concept of gate control theory. In order to construct the ASPM, three blocks should be considered, i.e. pain model connected to S fiber, external stimulation model of skin connected to L fiber and gate control block.

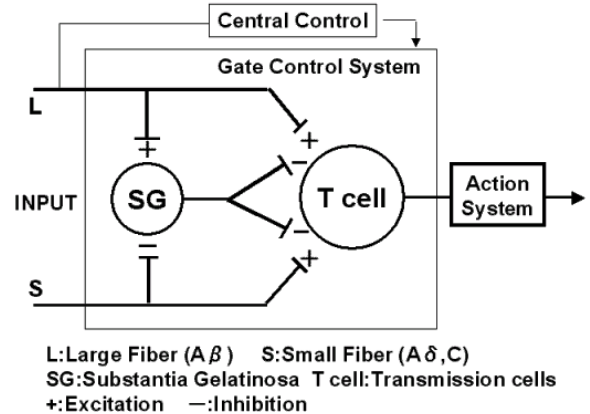

Fig. 6. Gate Control Model

#### 4.1. Mechanical Modeling of Continuous Pain

Response of the superficial pain has twin peaks, and lasts for a while. Mechanical modeling of such superficial pain is considered focused on these features.

Continuous pain with two peaks, i.e. fast pain and slow pain, can be described by two mass system shown in Fig.7. In the model, the pain level is expressed by the position of  $m_2$ .

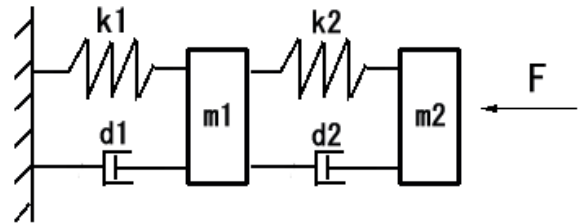

Fig. 7. Pain model by two mass model

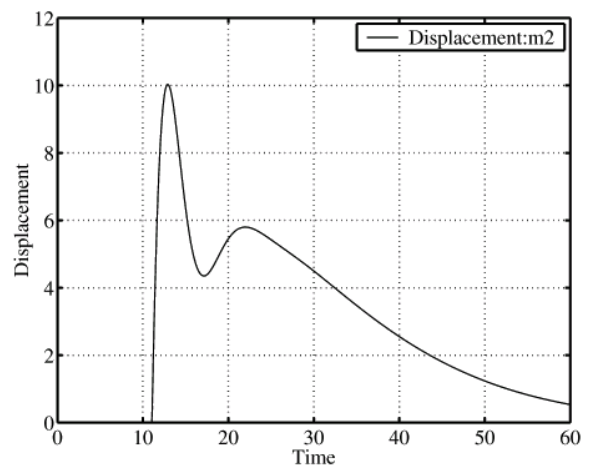

Fig. 8. Response of pain model (displacement  $m_2$ )

As pain is subjective sensation, it does not have a objective criterion. So we let the output of the model be normalized between 0 to 10 for the arbitrary impact. Model outputs are given in Fig.8 where the model parameters are adjusted so as to close to the response of subject A shown in Fig.4.

As shown in Fig.8, fast pain is caused by impulse input at  $t = 10[s]$  and slow pain occurs at  $t = 22[s]$ . Comparing with Fig.8 and Fig.4, it is concluded that the simple two mass system can express the continuous pain response of subject A.

#### 4.2. Elastic Skin Model for External Stimulation

Dynamic skin model for touch signals added to L fiber is considered. It is well known that the collagen in the skin is deformed by small force [10]. Kinoshita et.al. proposed the skin model such that the output is proportional to the external force, assuming skin is isotropic elastomer [9]. In this paper, we assume that skin is made by isotropic elastomer and expressed as Fig.9.

Simulation result is shown in Fig.10 when object touches on the skin from 2.5[s] to 7[s], where the parameters  $k_{s1}, k_{s2}, d_{s2}$  are set to the same value in literature [9].

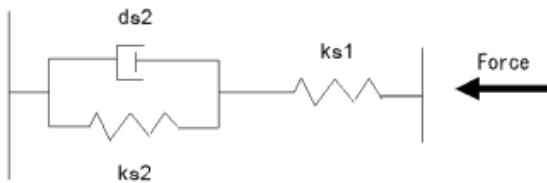

Fig. 9. Mechanical model of skin

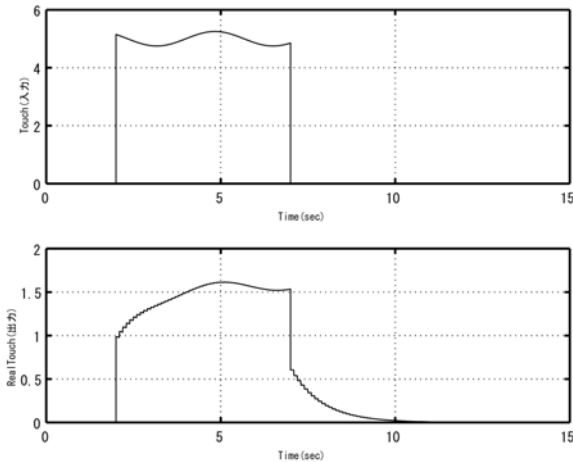

Fig. 10. Simulation results of deformed skin

#### 4.3. Gate Control using ANNs

Gate control theory is simple and easily understandable, but it is pointed out that this model is not correct in medical science because of no consideration about neurotransmitter to repress the pain. Schematic diagram of pain transmission system is described in Fig.11 [11]. In the figure, "brain" indicates the midbrain, cortex and thalamus and affects to transmission rate of affects.

There is some studies on neurotransmission model of pain in medical science, but it has not been cleared yet. Also, from the view point of molecular biology, mathematical model of the pain has been studied. They focus on the ion receptors and ion generation [6]. From the view point of neurophysiology, pain model using artificial neural networks (ANNs) has been studied, but there are no experiments and aspects

about industrial applications. As the affects of pain neuro-transmission from the brain is nonlinear and depends on individuals, we describe the gate control model by using ANNs with three layers as shown in Fig.12. Number of neurons in hidden layer is four, and moment method is applied.

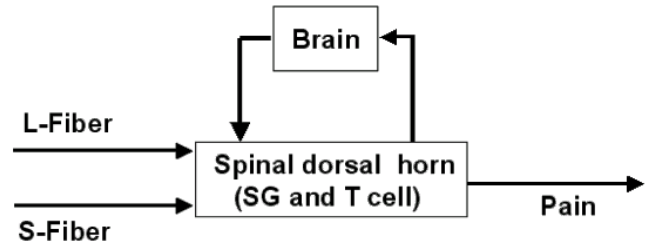

Fig. 11. Construction of pain transmission with the brain and spinal code

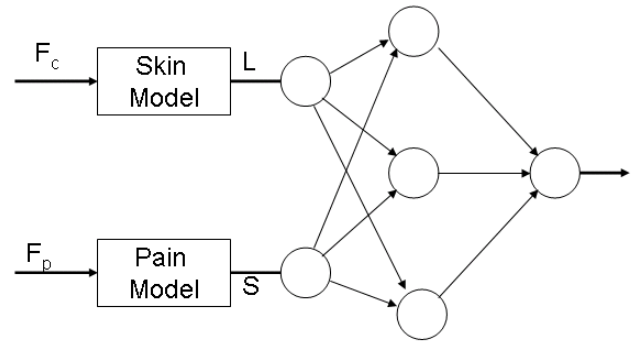

Fig. 12. ASPM using ANNs

For ANNs to learn the input/output relations, proper teaching signals are required. To get the teaching signals, we made the experiment shown in Fig.13.

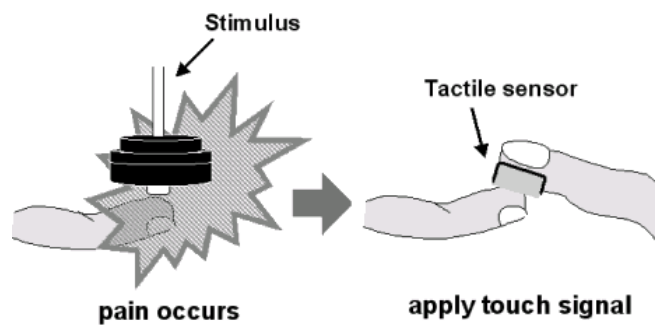
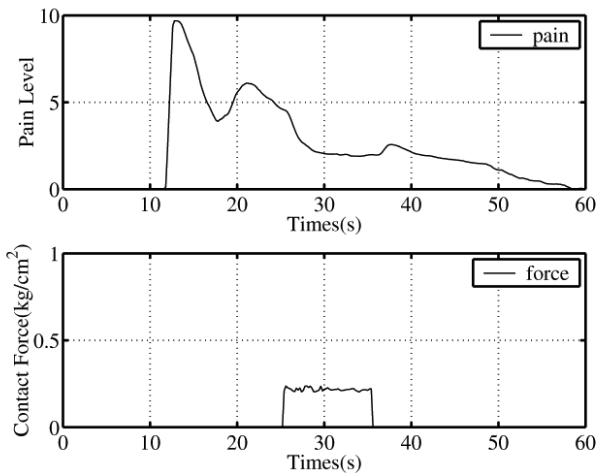
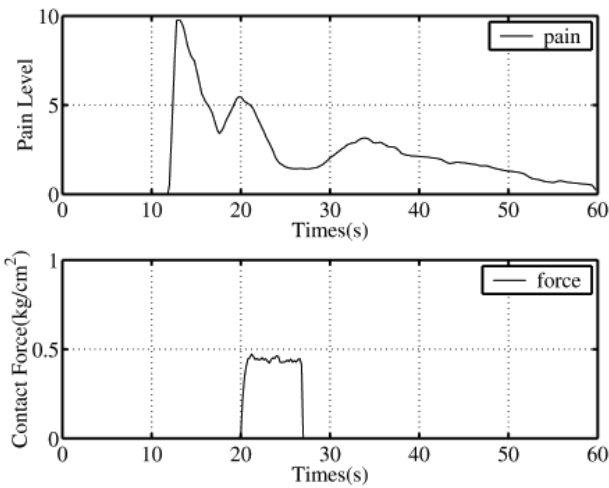

Fig. 13. Experiments for gate control (lessen of pain)

In the experiment, the skin around impact point is touched after impact damage, and change of pain level is measured. The figures (a) and (b) in Fig.14 show the experimental results when the skin is touched with arbitrary force around impact point. Fig.(a) and (b) show the pain level where small ( $0.25kg/cm^2$ ) and large ( $0.45kg/cm^2$ ) stimulation are added after second peek of pain, respectively. From these figures, we found that pain is lessened in case of touch the skin around impact point. Simulation results with the proposed ASPM are shown in Fig.15 to Fig.18. The output of ASPM



(a) Teacher signal 1



(b) Teacher signal 2

Fig. 14. Example of teacher signal (experiments)

without contact is shown in Fig.15. Fig.16 shows the simulation results with  $600g/m^2$  stimulation before second peak (20[s]). Fig.17 and Fig.18 show the simulation results with  $200g/m^2$  stimulation and  $600g/m^2$  stimulation after second peak (30[s]), respectively. Comparing with the teaching signal shown in Fig.14, it is summarized that the output of ASPM is closed to the experimental result, and ASPM can emulate the pain response of subject A.

## 5. CONCLUSION

In this paper, focusing on superficial pain caused by impact damage, we have proposed a new artificial superficial model (ASPM). Superficial pain and contact to the skin were modeled using two mass mechanical model and elastic model, respectively. Furthermore, control of pain transmission based on the gate control theory is constructed using ANNs.

The effectiveness of the proposed ASPM is evaluated with some experimental data. As the proposed model can express the personal pain characteristics, the anthropomorphic machine or robot that has the human's subjective pain will be realized.

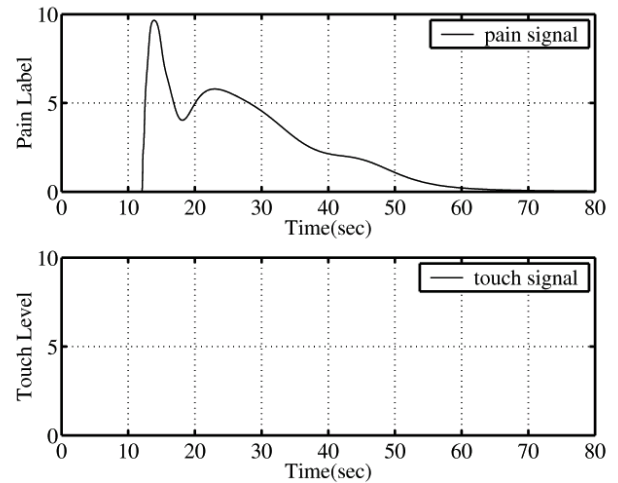

Fig. 15. Output of Neural Network: contact force  $0g/m^2$

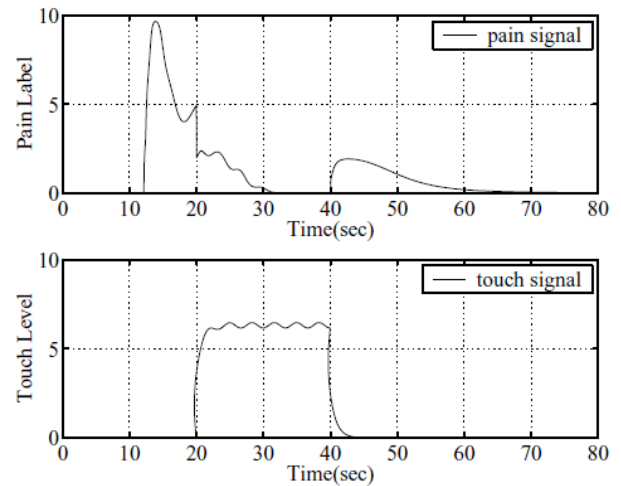

Fig. 16. Output of Neural Network: contact force  $600g/m^2$

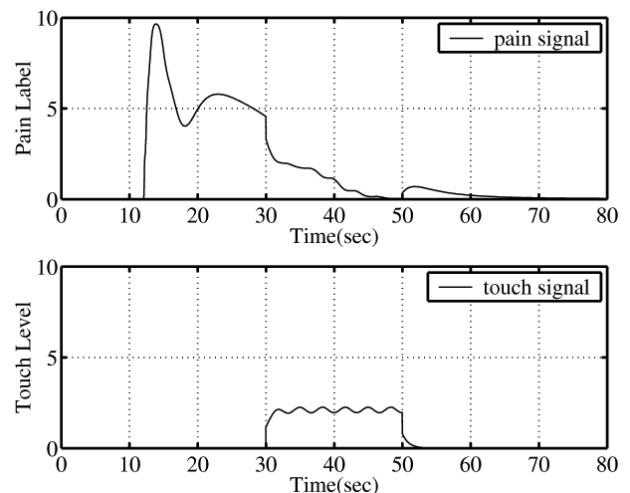

Fig. 17. Output of Neural Network: contact force  $200g/m^2$

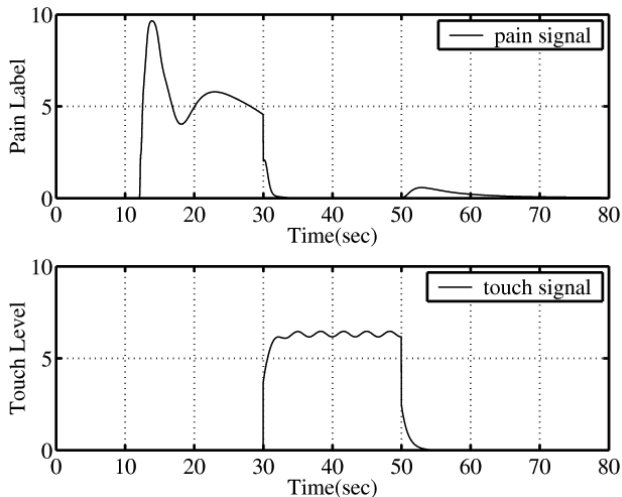

Fig. 18. Output of Neural Network: contact force  $600g/m^2$

Nominal pain model depending on the configuration or work condition of human and extend to other type of pain, e.g. chronic-pain, should be considered to generalization of the proposed model. Furthermore, learning method using the pain model and its application to robot are future investigations.

### References

- [1] K.Ikuta and M.Nonaka; "General Evaluation method of Safety Strategy for Welfare Robot", Journal of the robots society of Japan, Vol.17,No.3,pp363-370,1999 (in Japanese)
- [2] Y.Yamada, et.al.; "A Robot System with Safe Contact Detection and Stopping Capabilities Based on Human Pain Tolerance", Journal of the Japan society of mechatronics engineering, Vol.63, No.614, pp232-237,1997 (in Japanese)
- [3] Y.Yamada and N.Sugimoto; "Evaluation of Human Pain Tolerance", Journal of the robots society of Japan, Vol13, No.5, pp.639-642, 1995 (in Japanese)
- [4] T.Morita et.al.; "Anti collision Safety Design and Control Mythology for Human-Symbolic Robot Manipulator", Journal of the robots society of Japan, Vol.16, No.1,pp.102-109, 1998 (in Japanese)
- [5] Robert F.schmidt: "Fundamentals of Sensory Physiology", 2nd edition, Springer, 1986
- [6] D.Andrew, J.D.Greenspan; "Peripheral Coding of Tonic Mechanicoo Cutaneous Pain; "Comparison of Nociceptor Activity in Rat and Human Psychophysics", The American Physiological Society,pp.2641-2648,1999
- [7] M.Haeri, D.Asemani, S.Gharibzadeh; "Modeling of Pain Using Artificial Neural Networks", Journal of Theoretical Biology, Vol.220, pp.277-284, 2003
- [8] N.F.Britton, S.M.Slevington, "A mathematical model of the gate control theory of pain", Journal of Theoretical Biology, Vol.137, pp.91-105, 1989
- [9] G.Kinoshita and M.Mori; "An Elastic Model of Skin and Some Properties on the Variable Threshold Pro-

cessing of an Artificial Tactile Sence", Journal of the society of instrument and control engineering, Vol.8, No.4, pp10-17, 1972 (in Japanese)

- [10] H.Silver, M.Siperko, P.Seehra; "Mechanobiology of force transduction in dermal tissue", Skin Research and Technology, Vol.9, pp3-23, 2003
- [11] Kelly D.Young; "Pediatric Procedural Pain", Annals of Emergency Medicine", 2005