

A Backlight Feedback Control System with Integrated Color Sensor on LCD

**Ki-Chan Lee, Yun-Jae Park, Hyunseok Ko, Seung-Hwan Moon,
Jin-Hyeok Park, Brian Berkeley and Sang-Soo Kim**
LCD Development Center, Samsung Electronics, Co., Ltd.,
Myungam-ri, Asan-si, Chungnam-do, Korea

Abstract

In this paper, to improve the well-known photo conductivity degradation of amorphous silicon, a new LASER immersion treatment has been applied. The optical feedback control LED backlighting system with integrated LCD panel sensor increased the color variation less than 0.008 $\Delta u'v'$ compared to 0.025 for a non-feedback system.

1. Introduction

TFT LCD's have the largest market share of all digital flat panel displays. A three color RGB LED LCD backlighting system is very attractive considering wide color gamut, tunable white point, high dimming ratio, long lifetime and environmental compatibility [1]. However, the high intensity LED has thermal and time-based dependencies[1][2]. Color and white luminance levels are not stable over a wide range of temperature due to inherent long term aging characteristics.

In this paper, we present for the first time the feasibility of an optical color sensing feedback system for an LED backlight by integrating the amorphous silicon color sensor onto the TFT LCD panel. A new LASER immersion treatment has been applied in this paper to improve the well-known photo conductivity degradation of amorphous silicon[3].

2. Integrated Sensor on LCD

In order to minimize color point and brightness differences over time, optical feedback control is a key technology for any LED backlighting system. The amorphous silicon photoconductive sensor in Figure 1 was integrated onto a 17" SXGA LCD panel.

The fabricated sensor in Figure 2 has an inter-comb structure to maximize photo-detection area and electron drift channel width. The sensor electrode gap is 10 μm with a channel width of 9000 μm and total area of 1 x 3 mm².

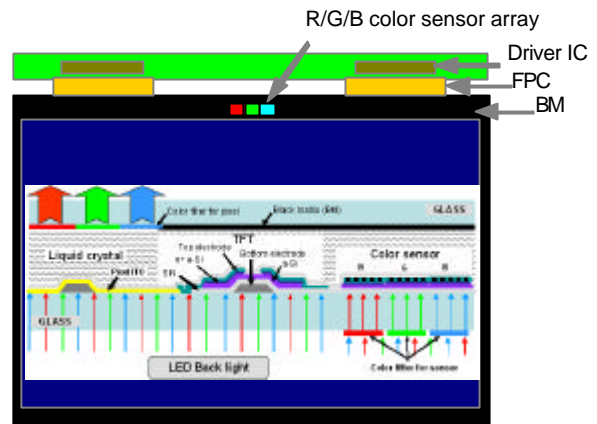

Figure 1. Amorphous silicon photoconductive color sensor integrated onto TFT LCD panel

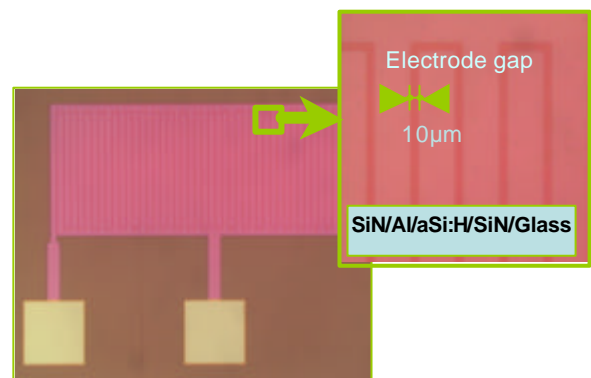

Figure 2. Photograph of amorphous Si photoconductive sensor fabricated using TFT LCD process

A new approach for improving long term photo stability using high energy LASER immersion is investigated in this paper. This instant light immersion process helps a-Si:H reach the saturated state of photo-induced dangling bond. At this state, the a-Si:H photo sensor in Figure 3 shows significant improvement in repeatability, approximately 98 %, in contrast to 82% without the laser treatment.

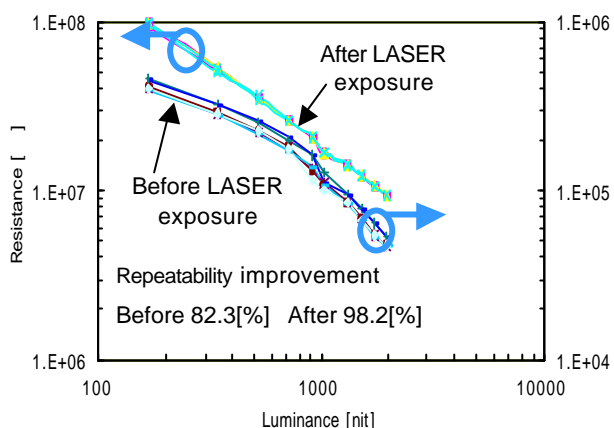

Figure 3. Measured photo-stability improvement after LASER treatment of the optical sensor

Measured spectral sensitivity on the back and front side of the optical sensor covers the entire visual light spectrum. To measure color, RGB color filters were placed at the back side the fabricated optical sensor. The measured relative spectral sensitivity of the sensor is suitable for the mixed R/G/B light of LED spectrum.

3. Optical Feedback Control

The 17" LCD LED backlight optical feedback control system utilizes the fabricated color sensor, signal averaging amplification module (G_S), analog operation block, PWM generator and feedback amplification (G_F) as shown in Figure 4. In this system, the color sensor detects the luminance of each RGB LED and provides an electrical signal to the analog controller for comparison between initial set values (V_{set}) and the measured values. If there is a difference between the set and measured values, the controller compensates the PWM signal to the LED power driver.

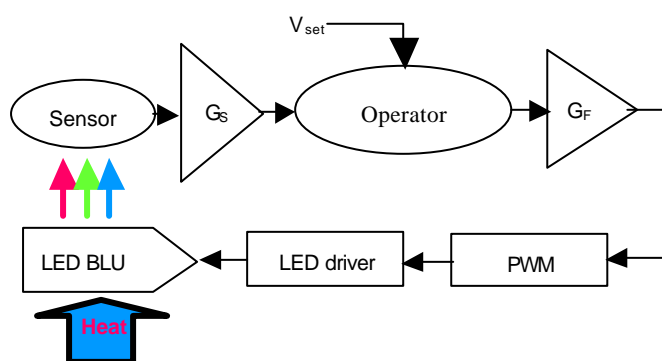

Figure 4. Schematic block diagram of optical feedback control system for LED backlight system

The compared color stability between the non-feedback (open loop) and the optical feedback (closed loop) control systems is shown in Figure 5. The optical feedback LED backlighting system with integrated LCD panel sensor increased the color variation less than $0.008 \ u' \ v'$ compared to 0.025 for a non-feedback system. Additionally, white luminance level variation is controlled to less than 5 nits over temperature range of 42 to 76 .

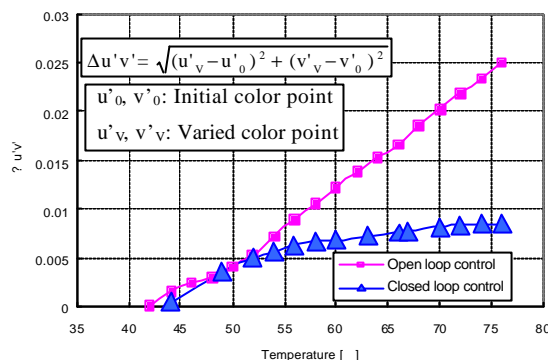

Figure 5. Measured color point difference from initial set value comparing open loop and closed loop LED backlight color stability performance

4. Conclusion

To improve photo conductivity degradation of amorphous silicon as an optical sensor, a new LASER immersion treatment has been applied. The integrated color sensor optical feedback controlled LED backlighting system improved the color variation significantly compared with an open loop system over temperature.

5. References

- [1] G. Harbers, and C.G.A. Hoelen, High Performance LCD Backlighting using High Intensity Red, Green and Blue Light Emitting Diodes, SID Intl. Symp. Digest Tech. Papers, pp. 702-706 (2001).
- [2] Subramanian Muthu, Frank J. Schuurmans, Michael D. Pashley, Red, Green, and Blue LED based White Light Generation: Issues and Control, IEEE, J. on selected topics in quantum electronics, Vol. 8, No. 2, pp. 327-332 (2002).
- [3] D.L. Staebler and C.R. Wronski, Optically induced conductivity changes in discharge-produced hydrogenated amorphous silicon, Journal of applied physics, Vol. 51, No. 6, pp. 3262-3268 (1980).