

상용전원을 제어하는 CO2레이저의 출력 조절에 관한 연구

정종진, 이임근, 박성진, 김희제
부산대학교 전기공학과

A study on the adjusting output energy of the CO2 laser controlled directly in AC power line

Jong-jin Jeong, Jin-young Choi, Sung-jin Park, Gun-ju Song, Hee-je Kim
Department of Electrical Engineering, Pusan National University

Abstract

We demonstrate a simple CO2 laser by controlling firing angle of a TRIAC switch in ac power line. The power supply for our laser system switches the voltage of the AC power line (60Hz) directly. The power supply does not need elements such as a rectifier bridge, energy-storage capacitors, or a current-limiting resistor in the discharge circuit. In order to control the laser output power, the pulse repetition rate is adjusted up to 60Hz and the firing angle of TRIAC gate is varied from 45 to 135. A ZCS(Zero Crossing Switch) circuit and a PIC one-chip microprocessor are used to control the gate signal of the TRIAC precisely.

The maximum laser output of 40W is obtained at a total pressure of 18Torr, a pulse repetition rate of 60Hz, and a TRIAC gate firing angle of 90.

Instruction

A CO2 laser system designer is usually interested in maximizing the laser output power subject to a variety of restrictions such as size, cost, efficiency, and stability. In earlier report, we introduced a 60Hz AC discharge for pumping the gas mixture of a low-power CO2 laser with output power below 100W[1,2]. The power supply does not need electronic elements such as a rectifier bridge, an energy-storage capacitor, or a current limiting resistor in the discharge circuit because of the direct use of the ac (60Hz) power line and the inner impedance of the leakage transformer. Thus, this has many profits in cost, size and efficiency comparing with typical DC power supply for CO2 laser[3].

However, in that laser system, the laser output power could be only adjusted by a slide type-voltage regulator. This was very difficult to control laser output power precisely. In order to solve this problem, in this paper, we introduce a simple CO2 laser system using a TRIAC semiconductor switch which is connected with the transformer primary instead of the voltage regulator. We can obtain desirable laser output power by varying the number of pulse and a firing angle of the AC line voltage switched on the transformer primary. Also, in this power supply, there is no need of a rectified bridge, an energy storage capacitor, and a current-limiting resistor.

Experiment and result

The type of lasers that we are investigating are sealed water-cooled devices made of Pyrex™ glass. The experiment is equipped with a plano-concave. The optical resonator is formed by a totally reflecting Mo mirror with a radius of curvature of 10 m and a 90 % reflecting ZnSe flat output coupler separated by 95 cm. The length of discharge tube is about 80 cm.

As shown in Fig. 1, a power supply for exciting the gas molecules is composed of two main circuits, a TRIAC control circuit and a discharge circuit. The former includes a ZCS(Zero Crossing Switch) circuit and a PIC one-chip microprocessor. The latter includes a TRIAC(Sanrex:TG35C) , a leakage transformer.

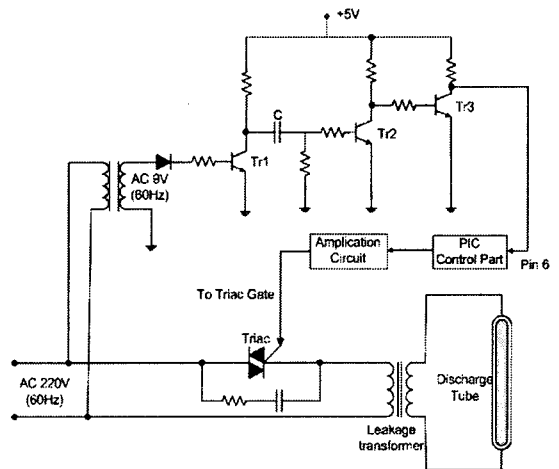

Fig. 1 The electrical circuit consisting of three major components : a ZCS circuit, a PIC one-chip microprocessor, and a discharge circuit.

The ZCS circuit detects the zero voltage of the AC line and then transfers the information to the PIC one-chip microprocessor. As shown in Fig. 2, the ZCS circuit makes 60 pulses per second at the zero voltage of the AC line. 60 pulse signals per second from Tr3 in ZCS are applied to pin 6 called RTCC(Real Time Clock Count) in PIC16F877. The desirable trigger pulse repetition rate of the TRIAC gate is given by the ratio of input pulses in pin 6 versus output pulses in pin 15, 16 of

PIC. The PIC also controls the firing angle of a TRIAC from 45 to 135 in order to investigate the influence of the initial value of the input voltage on the laser output power. Fig 2 shows the voltage waveform of the AC line, pulse signals generated from the ZCS circuit, and the gate trigger signals with trigger pulse delay angle of 90 at 60Hz.

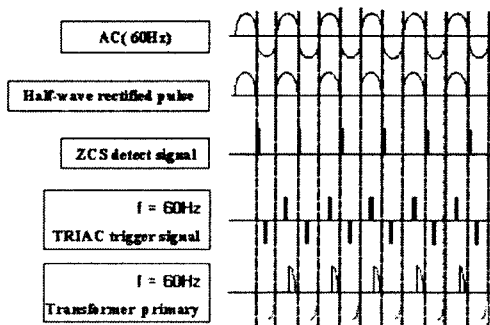

Fig. 2 The voltage waveform of the AC line, pulse signals generated from the ZCS circuit, and the gate trigger signals with trigger pulse delay angle of 90 at 60Hz.

As shown in Fig. 1, a leakage transformer (also called a neon transformer) is employed in the power supply. The transformer produces a peak voltage pulse of up to 25 kV and its rating capacity is 300 VA.

Neon-sign transformers have a large leakage reactance that serves to limit the high current in the secondary circuit due to the sudden impedance drop of the load[4]. Thus, this prevents glow discharges from transition to arc discharges in the neon-sign tubes. The same benefit can be obtained when using as transformer to drive discharge in the CO₂ laser because the discharge tube characteristics for the low-pressure CO₂ laser are very similar to that for neon-sign tubes. Also, in the proposed circuit, no energy storage elements like capacitors are needed since the AC power line is directly switched on the transformer primary.

The experiment has been conducted with a CO₂/N₂/He = 1/9/15 gas mix. When considering the relationship between the laser output power and the filling pressure, the best condition of the filling pressure was 18 Torr. And we measured the average output power using an energy meter(Gentec:PS-1k).

In Fig. 3, the laser output power versus the various TRIAC gate firing angle is plotted for the separate pulse repetition rate. The TRIAC trigger pulse is delayed from 45 to 135 by the PIC program in order to investigate the influence of the initial values of the input voltage on the laser output power. From these experimental data, it is found that the maximum laser power is obtained when the trigger pulse is applied to TRIAC gate with a firing angle close to 90 and the pulse repetition rate of 60Hz, that is at the time of the peak voltage of the AC line. As a result, we found that the magnitude of the input peak voltage is more important than the discharge time length.

Fig. 4 shows laser output vs. separate pulse repetition rate with trigger pulse delay angle of 90. It means that the laser output we

want can be obtained by Varying the number of pulse.

In summary, we described a simple CO₂ laser system by

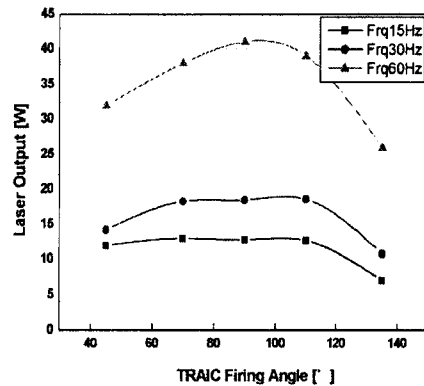

Fig. 3 Laser output power vs. TRIAC gate firing angle at separate pulse repetition rate.

controlling the firing angle of a TRIAC which is connected with the transformer primary. As a result, we can obtain a desirable laser output power by varying the number of pulse and controlling the firing angle in the power supply. It also offers some advantages to the cost and size compared to a typical pulsed power supply for CO₂ laser because it doesn't require a charging element and a current-limiting device.

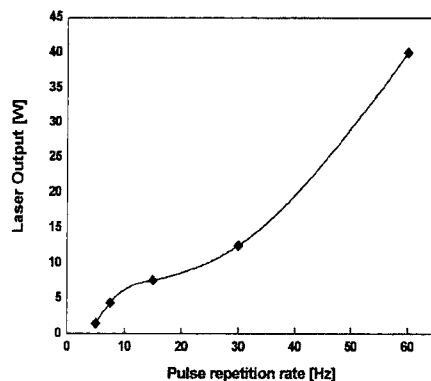

Fig. 4 The laser output vs. separate pulse repetition rate with trigger pulse delay angle of 90.

[Reference]

- [1] Dong-Hoon Lee, Hyun-Ju Chung, and Hee-Je Kim. Comparison of dc and ac excitation of a sealed CO₂ laser, Review of Scientific Inc; 2000, Feb, P.577-578
- [2] Dong-Hoon Lee, Hyun-Ju Chung, and Hee-Je Kim. Effect of leakage transformer on laser power and mode pattern of CO₂ laser excited by 60Hz AC discharges, Optics and Lasers in Engineering 32(1999) 49-53
- [3] W Koechner. Solid-State Laser Engineering Springer Berlin 1996; 330-338
- [4] T. Wildi, Electrical Machines, Drives, and Power System, Prentice-Hall, Englewood Cliffs, NJ, 1997