레이저를 이용한 분무 가시화

Spray Visualization Using Laser Diagnostics

윤 영 빈 교수
서울대학교 기계항공공학부

분무를 정량적으로 측정하는 것은 노즐의 설계와 개발을 위해서 뿐만 아니라 연소 시스템 전반의 효율 및 불안정성의 제거, 공해 저감 등의 요구 조건을 만족하기 위해서 중요하다. 이를 위해 이전에는 분무장 내에 수집관을 삽입하는 기계적 패터네이터(Mechanical Patternator)와 같은 삽입식 측정 방식을 이용하여 왔으나, 최근에는 고속카메라, Malvern particle analyzer, PDPA, 광학 패터네이터(Optical Patternator)와 같은 분무장을 교란 시키지 않으면서도 빠른 측정이 가능한 가시화 기술들이 적용되고 있다. 특히 광학 패터네이터는 레이저 평면광을 이용하여 분무를 측정하는 비삽입식 기술로 단시간 내에 분무장 내 액체 연료의 질량 및 액적 크기의 단면 분포를 동시에 얻어낼 수 있는 장점을 갖고 있다. 그러나 분무 액적들의 수밀도가 증가하는 경우에는 이들 액적에 의한 입사광 및 신호 감쇠, 다중 산란 등에 의한 오차가 심하게 발생하여, 기존의 PDPA, PLIF 등의 광학 기법으로는 충분히 신뢰할 만한 결과를 얻기가 어렵게 된다. 이러한 분무를 정량적으로 측정하기 위해서는 입사광의 감쇠뿐만 아니라 분무장 내 액적들에 의한 신호의 감쇠 과정에 대한 고려가 필요하다. 주변 액적들의 영향을 최소한으로 줄이기 위해서는 레이저 평면광을 사용하는 광학 패터네이터와 달리 레이저 광선을 분무장에 조사하여 고압에서 나타날 수 있는 다중 산란에 의한 오차를 최소화할 수 있다. 이러한 이미지 처리 기법을 이용하는 광학 선형 패터네이터(Optical Line Patternator)를 이용하여 기존 레이저 계측기법으로 측정이 곤란하였던 고압 환경 하에서의 스월 동축형 인젝터의 분무 특성을 해석할 수가 있다.



레이저 계측법을 이용한 분무 가시화
Spray Visualization Using Laser Diagnostics

윤영빈

서울대학교 기계항공공학부

Seoul National University Rocket Propulsion Lab.



Part I. Introduction

Seoul National University Rocket Propulsion Lab.

Mechanical Patternator



- ❖ measure **mass-flux** collected in each segment

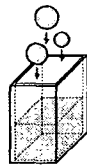

collected mass
per unit area & unit time

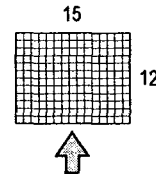

- ❖ Disadvantages:
 - ✓ spray-field perturbation
 - ✓ limited spatial resolution
 - ✓ slow measurement and intensive labor

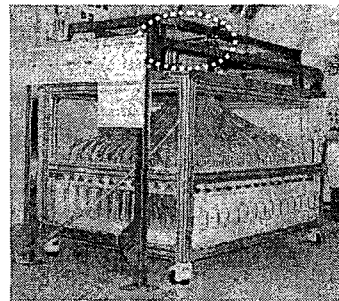

Optical Patternator



- Non-intrusive method
- Using Mie-scattering or Laser Induced Fluorescence
- 2-D Planar measurement
 - High spatial resolution
 - Rapid characterization
- Measurement parameter
 - Patterning
 - SMD
 - Relative mass distribution
 - Mass flux

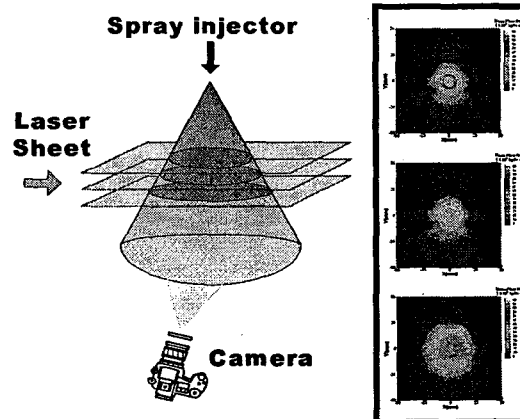

Previous Work



- Planar Laser Techniques
 - Extensively used in gas flows since early 1980s
 - Exiplex(Melton et al.,1985) : both gas and liquid concentrations
- Planar Liquid Laser Induced Fluorescence : UC Irvine (1995)
 - Mass distribution of fuel using the fluorescence signal
 - Experimental correction for the attenuation of the incident beam
- Laser Sheet Dropsizing : Cranfield Univ. (2000)
 - Uncertainty analysis of SMD measurement
- Commercial system
 - TSI : Optical Patternator
 - LaVision : Spray Master
 - En'Urga : SETscan Optical Patternator(*Statistical Extinction Tomography*)

Seoul National University Rocket Propulsion Lab.

Optical Patternator (TSI)

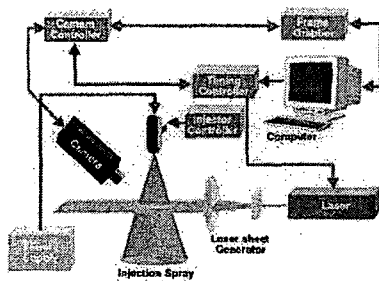

Light sheet in the horizontal plane

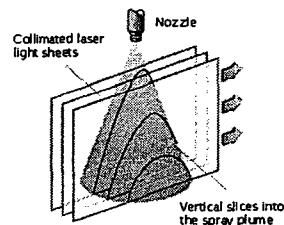
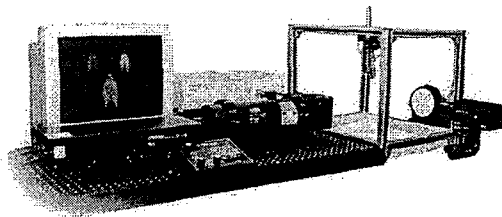

Seoul National University Rocket Propulsion Lab.

Measurement Principles (1)



Mie scattered Light Intensity $\propto d^2$

$$G_s(x, y) = I_o(x, y) c_s \sum N_i(x, y) d_i^2(x, y)$$

incident laser intensity / diameter of drops

scattering signal intensity at (x,y) point / num. of drops

Fluorescence Light Intensity $\propto d^3$

$$G_f(x, y) = I_o(x, y) c_f \sum N_i(x, y) d_i^3(x, y)$$

incident laser intensity / diameter of drops

fluorescence signal intensity at (x,y) point / num. of drops

Seoul National University Rocket Propulsion Lab.

Measurement Principles (2)



Mass Distribution

Proportional to the mass density of the dispersed phase, ρ

$$\Rightarrow G_f = C_f' I_o \delta m = C_f I_o \rho$$

Mass Flux, \dot{m}''

$$\dot{m}''(x, y) = \frac{G_f(x, y)}{S(z)} \frac{\dot{m}_{nozzle}}{A}$$

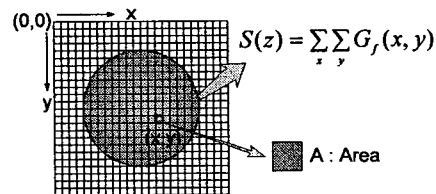

SMD(Sauter Mean Diameter)

$$\frac{G_f(x, y)}{G_s(x, y)} = \frac{c_f}{c_s} \left[\frac{\sum N_i(x, y) d_i^3(x, y)}{\sum N_i(x, y) d_i^2(x, y)} \right] = K D_{32}(x, y) \Rightarrow D_{32}(x, y) = \frac{1}{K} \left(\frac{G_f(x, y)}{G_s(x, y)} \right)$$

Seoul National University Rocket Propulsion Lab.

Characteristic of Dye Material



Emission spectrum

- Ar+ laser (514.5 nm)
- Dye : Fluorescein
(Aldrich F245-6,
 $C_{20}H_{12}O_5$)

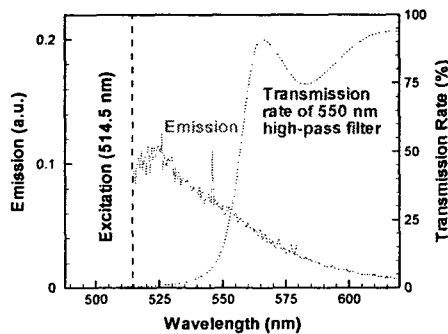

Index of fluorescence

$$G_f = 1.48 \times 10^{-6} \cdot D_p^{3.0006}$$

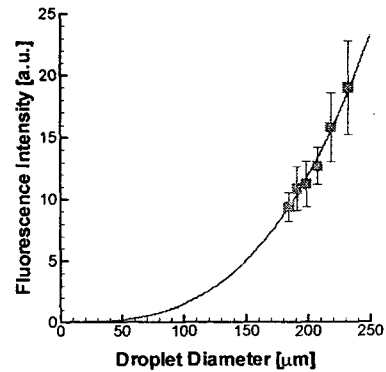

Seoul National University Rocket Propulsion Lab.

Error Sources



Laser Sheet Intensity Variation

- Gaussian beam
- Sheet beam optics

⇒ Quartz Cell Calibration

Perspective Error

⇒ Affine Transformation

Laser Sheet Extinction

⇒ Sequential illumination
(Talley et al. 1996)

Signal Attenuation

⇒ Objectives of this study!

Secondary Emission

- Emission from molecule(s) outside the plane by scattered energy
- Multiple scattering

⇒ Not Easy to quantify

Seoul National University Rocket Propulsion Lab.

Perspective error



❖ Grid image for calibration

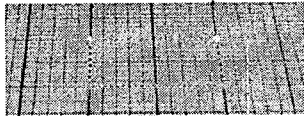

❖ Spray image

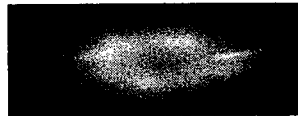

Affine Transformation

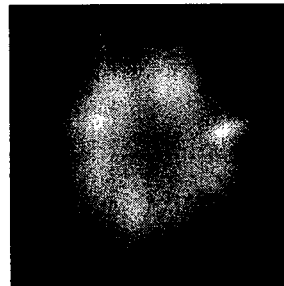
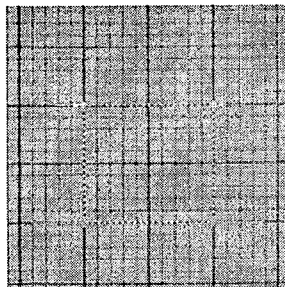

Seoul National University Rocket Propulsion Lab.

Laser Sheet Extinction

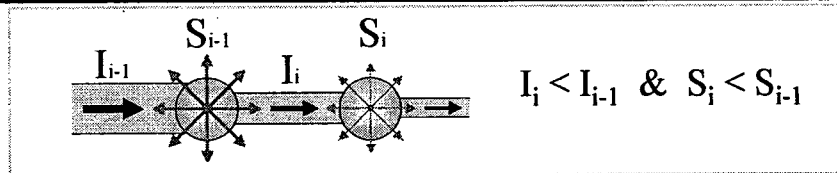

❖ Talley et al. (US Air Force, 1996)

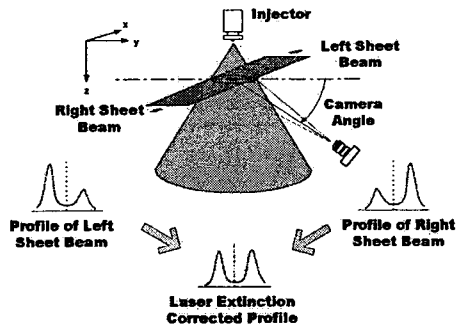

❖ Sellens et al. (Queen's Univ., 2000)

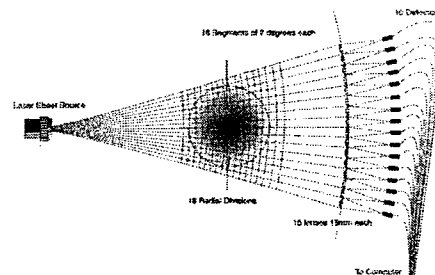

Seoul National University Rocket Propulsion Lab.

Signal Attenuation

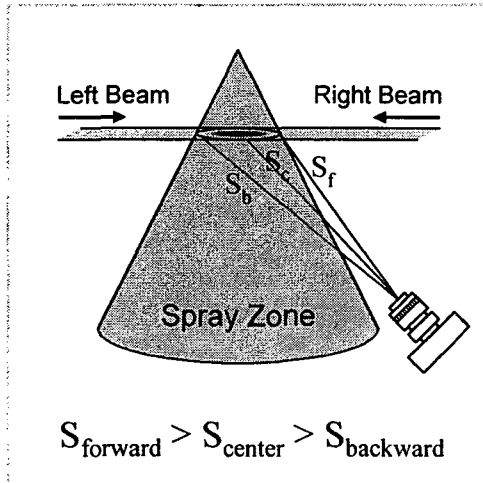

❖ Sankar et al. (Aerometrics Inc., 1999)

: SMD is not affected by attenuation

❖ Present Study (using 2 cameras)

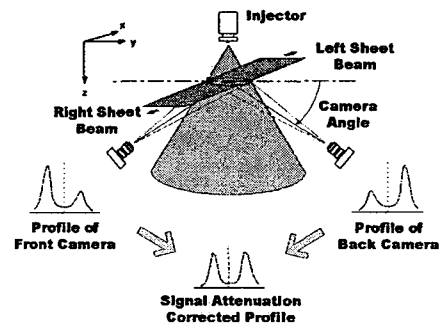

Seoul National University Rocket Propulsion Lab.

Secondary Emission

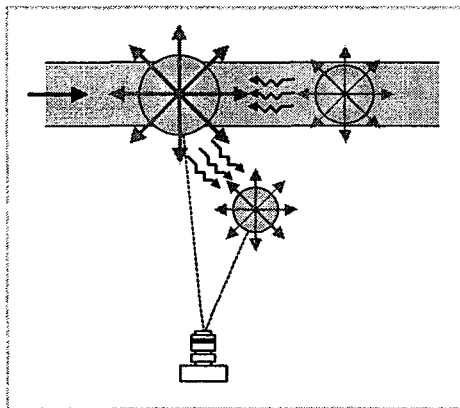

❖ Brown & Talley (2002)
: single beam sweeping

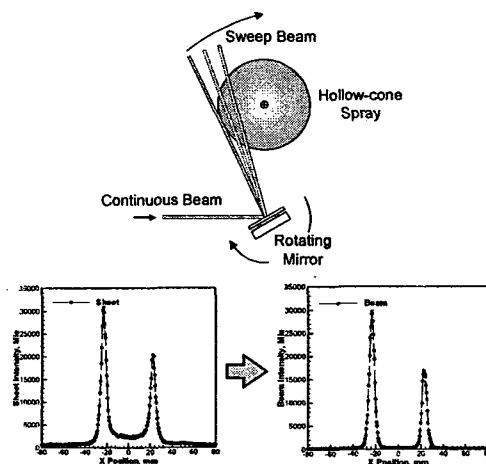

Seoul National University Rocket Propulsion Lab.



Part II. Correction of Laser/Signal Attenuation in Dense Spray

Seoul National University Rocket Propulsion Lab.

Correction of Signal Attenuation



❖ Beer's law

$$\begin{aligned} G_t &= G_0 \exp[-\tau] \\ &= G_0 \exp\left[-\int_0^L \gamma(s) ds\right] \end{aligned}$$

G_0 : original intensity
 G_t : transmitted signal
 τ : optical depth
 γ : attenuation coefficient
 s : signal path

- ❖ If the optical depth (τ) is constant throughout the spray, the attenuated intensity can be restored by **geometrical average using 2 cameras**.

$$\sqrt{G_1 G_2} = G_{real} \exp\left[-\frac{1}{2} \gamma (L_1 + L_2)\right] \approx K_{ext} G_{real}$$

$$G_{real} \approx \frac{1}{K_{ext}} \sqrt{G_1 G_2}$$

- ❖ Is optical depth $\gamma (L_1 + L_2)$ constant?



Errors are dependent on

- (i) **Sum of attenuation length**
 (ii) **Inhomogeneity of medium**

Seoul National University Rocket Propulsion Lab.

3-D Geometry for Signal Path

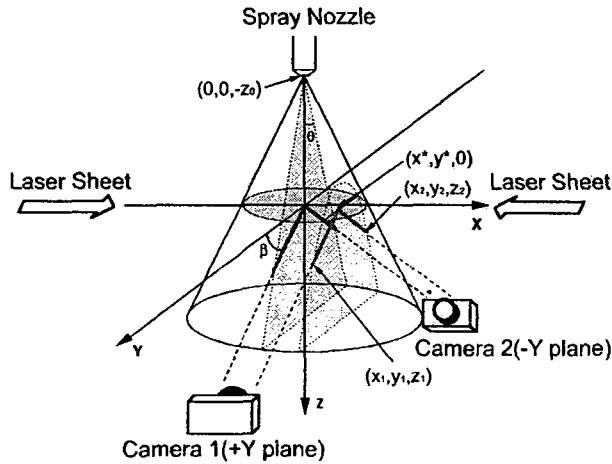

❖ Spray Cone Equation

$$x^2 + y^2 = (z + z_0)^2 \tan^2 \theta$$

❖ Signal Path Equation

- Meas. Pt. ~ Camera 1

$$s_1: (x^*, y^*, 0) \rightarrow (x_1, y_1, z_1)$$

$$\begin{cases} (x^*)^2 + y^2 = (z_1 + z_0)^2 \tan^2 \theta \\ z_1 = (y_1 - y^*) \tan \beta \end{cases}$$

- Meas. Pt. ~ Camera 2

$$s_2: (x^*, y^*, 0) \rightarrow (x_2, y_2, z_2)$$

$$\begin{cases} (x^*)^2 + y^2 = (z_2 + z_0)^2 \tan^2 \theta \\ z_2 = (y_2 - y^*) \tan \beta \end{cases}$$

Seoul National University Rocket Propulsion Lab.

Cross-section of Signal Path

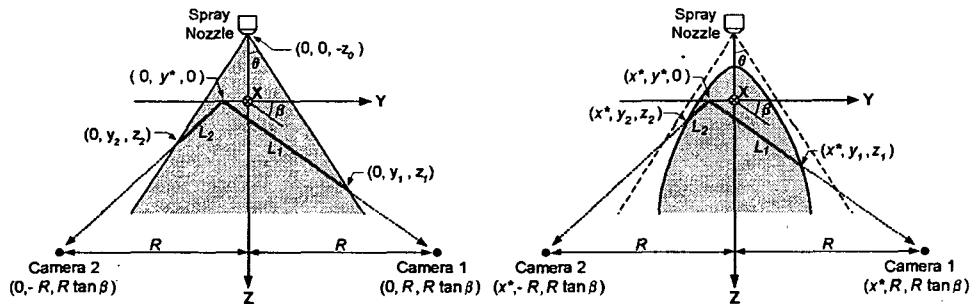

$x^* = 0$
(Straight Line Edge)

$x^* \neq 0$
(Hyperbola Edge)

Seoul National University Rocket Propulsion Lab.

Signal Path of x=0 plane



- ❖ Assumption
 - 2-D planar Analysis (X = 0 plane)
 - $\beta = \text{const.}$ (camera viewing angle)
 - $\theta = \text{const.}$ (spray cone angle)

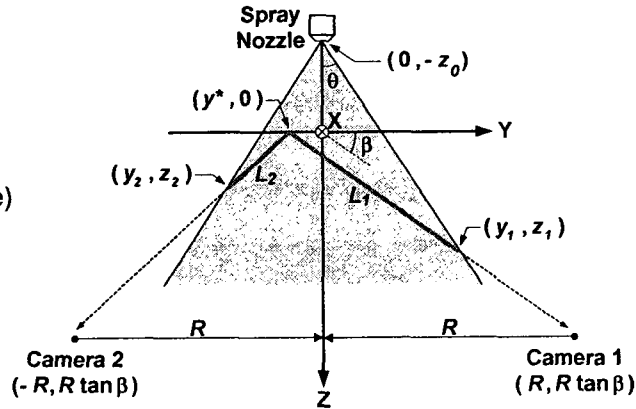

$$\sqrt{y^2 + z^2} = \sqrt{(1 + \tan^2 \beta) \left(\frac{1 - \tan^2 \beta}{2 \tan \beta} \right)^2} = \text{const.}$$

Attenuation Length (Signal Path)

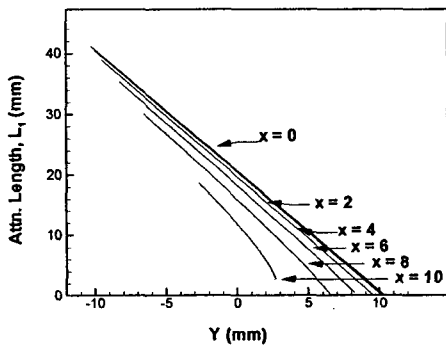

Single camera detection

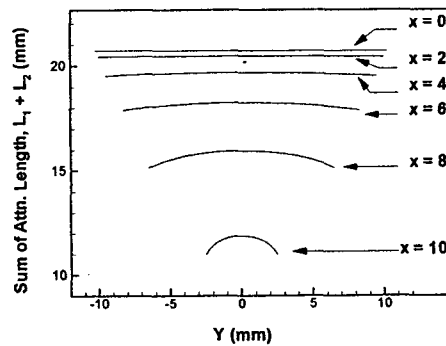

Two cameras detection (Sum of two length of signal path)

Attenuation Coeff. Measurement

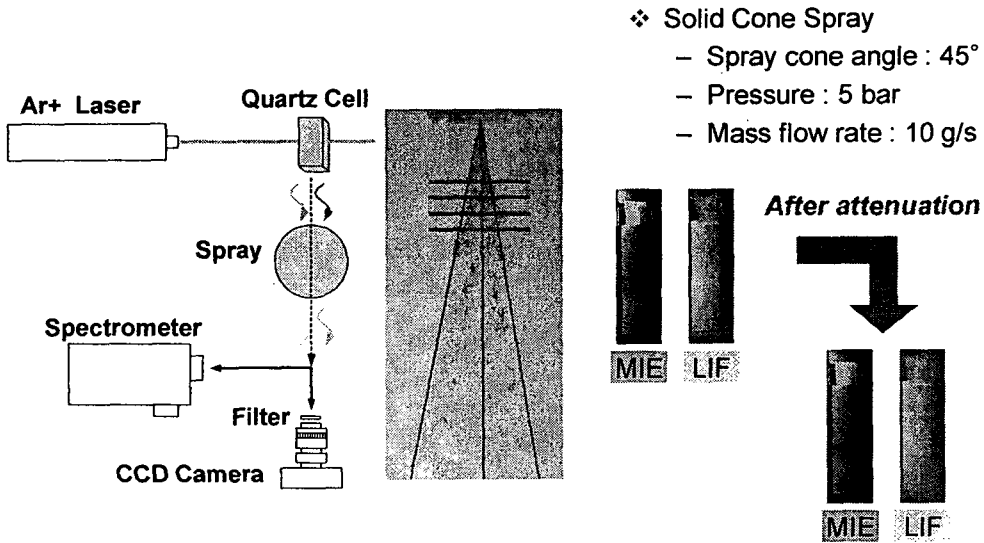

Seoul National University Rocket Propulsion Lab.

Attenuation Coefficients (γ_s, γ_f)

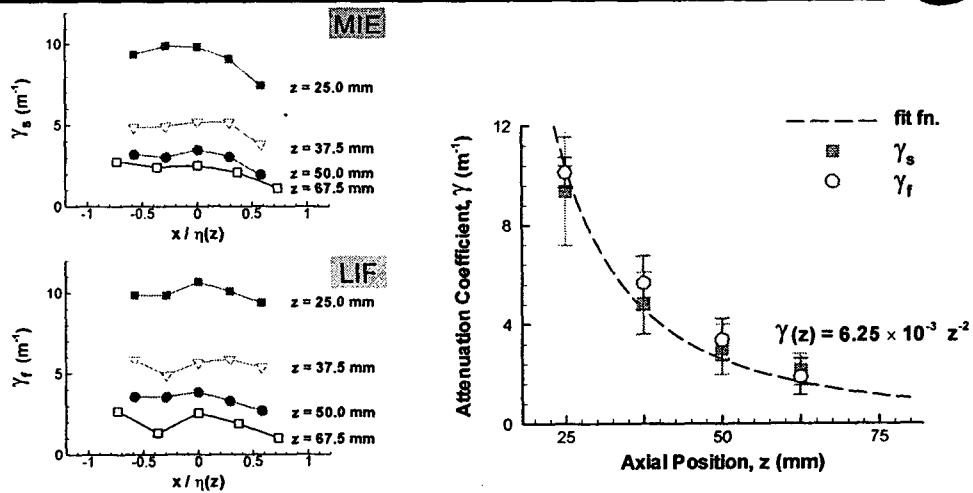

❖ Radial Variation : $\gamma = \gamma(x,y) \approx \text{const.}$

❖ Axial Variation : $\gamma = \gamma(z) \neq \text{const.}$

Seoul National University Rocket Propulsion Lab.

Calculation of Optical Depth



❖ Optical Depth (τ) = Attenuation Coeff. (γ) \times Signal Path (L)

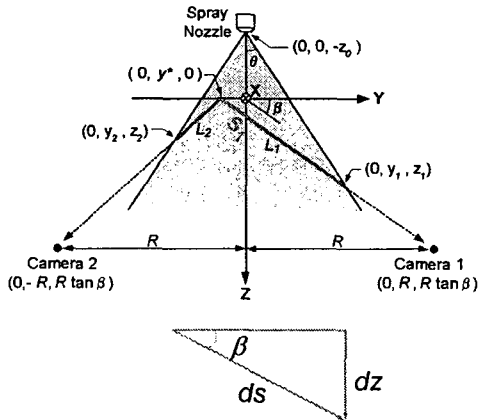

$$\gamma(z) = 6.5 \times 10^{-3} / (z + z_0)^2$$

$$ds = \frac{dz}{\sin \beta}$$

- Single camera detection

$$\tau = \int \gamma(s) ds$$

- Two camera detection (Geometrical Average)

$$\tau = \frac{1}{2} \left\{ \int_0^{L_1} \gamma(s_1) ds_1 + \int_0^{L_2} \gamma(s_2) ds_2 \right\}$$

Seoul National University Rocket Propulsion Lab.

Variation of Optical Depth

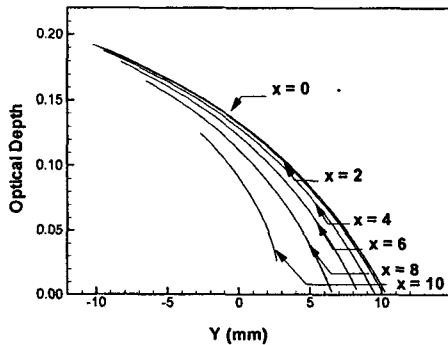

❖ Single camera detection at Z = 25 mm

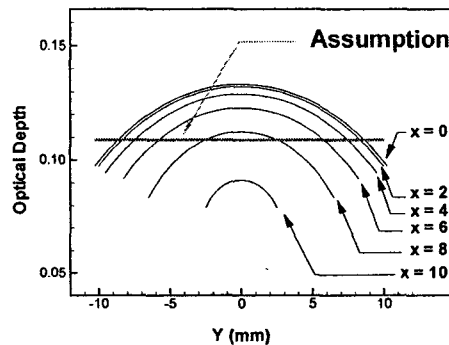

❖ Two camera detection at Z = 25 mm (Geometrical Average Method)

Optical depth is not constant.

➡ Errors due to Signal Attenuation

Seoul National University Rocket Propulsion Lab.

Estimated Attenuation Rate (Two Camera Detection)



The attenuation rate (ϵ) represents a measurement error due to signal attenuation: $\epsilon = (G_{\text{real}} - G_{\text{meas}}) / G_{\text{real}}$

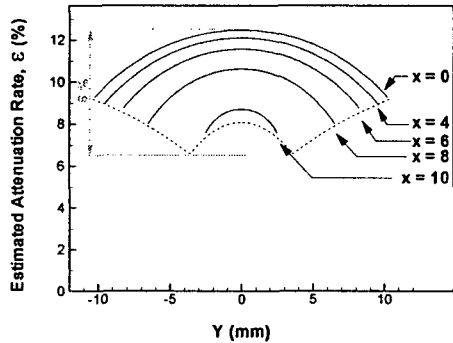

❖ $Z = 25 \text{ mm}$

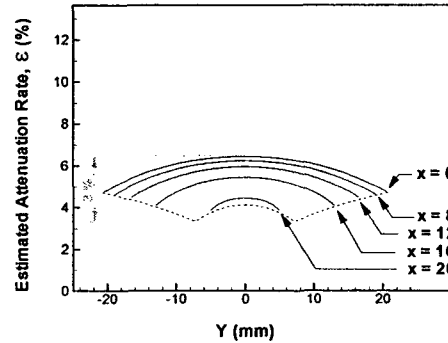

❖ $Z = 50 \text{ mm}$

Seoul National University Rocket Propulsion Lab.



Part III. Spray Visualization Using Optical Patternator

Seoul National University Rocket Propulsion Lab.

Patternation (Z=50mm)

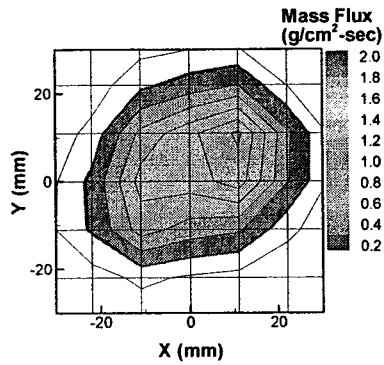

Mechanical Patternator

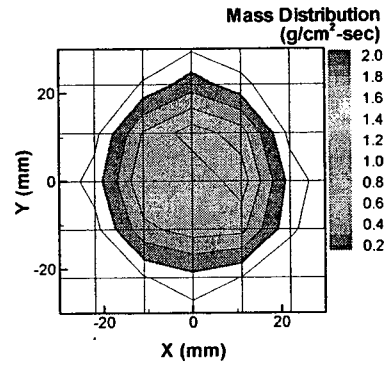

Optical Patternator

Seoul National University Rocket Propulsion Lab.

Mass Distribution and Mass Flux

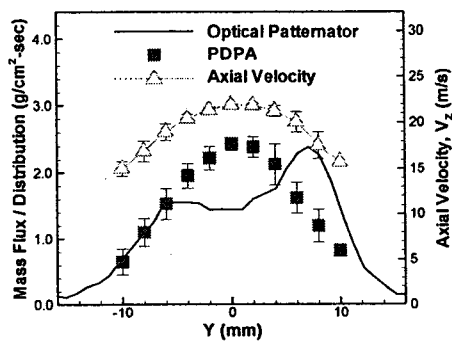

Z = 25 mm

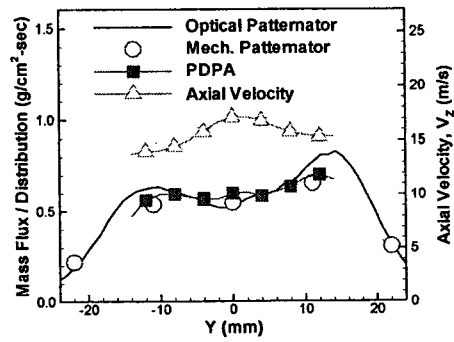

Z = 50 mm

Seoul National University Rocket Propulsion Lab.

Comparisons of SMD Meas.

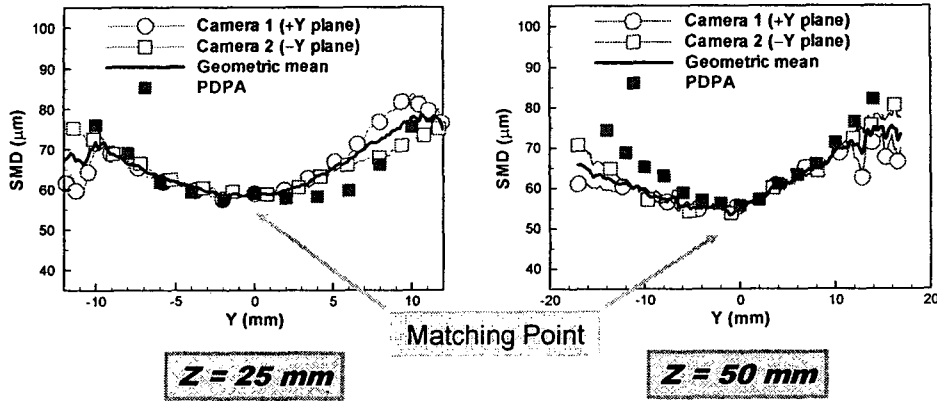

- Correction factor, K , was calculated to match a value with PDPA at the spray center ($x = 0$).

Seoul National University Rocket Propulsion Lab.

Measurement of Mixing Rates (Rocket Injector: KSR-III)

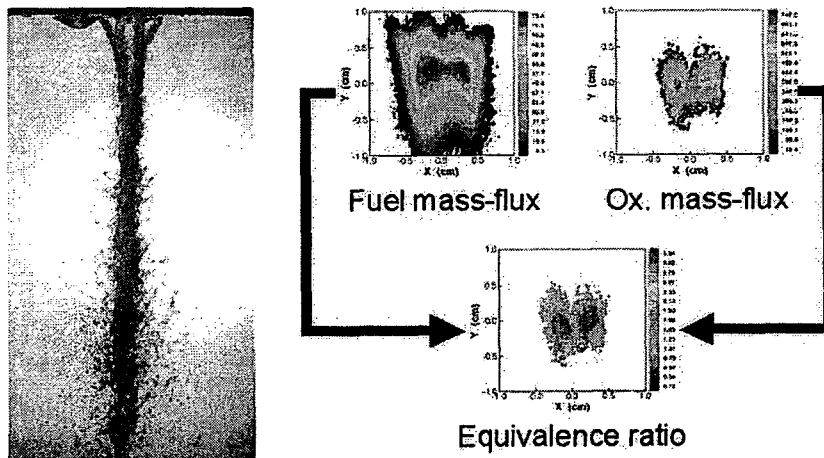

Seoul National University Rocket Propulsion Lab.

FOOF & FOF Injectors

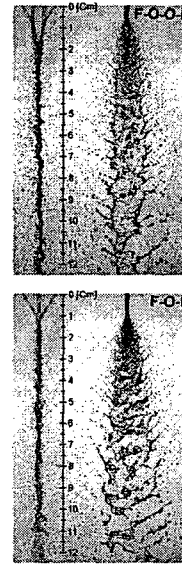
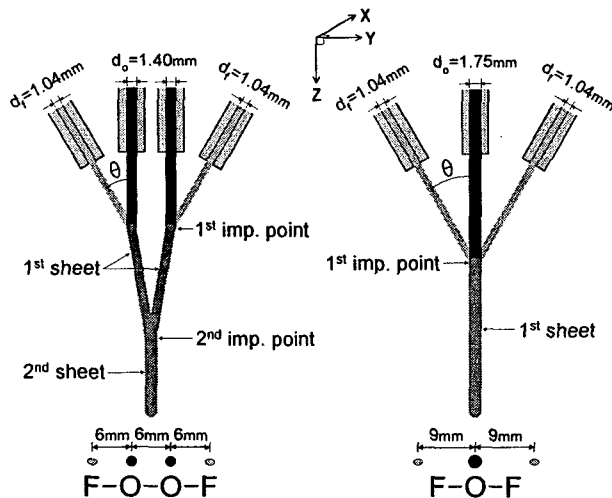

Seoul National University Rocket Propulsion Lab.

Mixing Process (F-O-O-F, F-O-F)

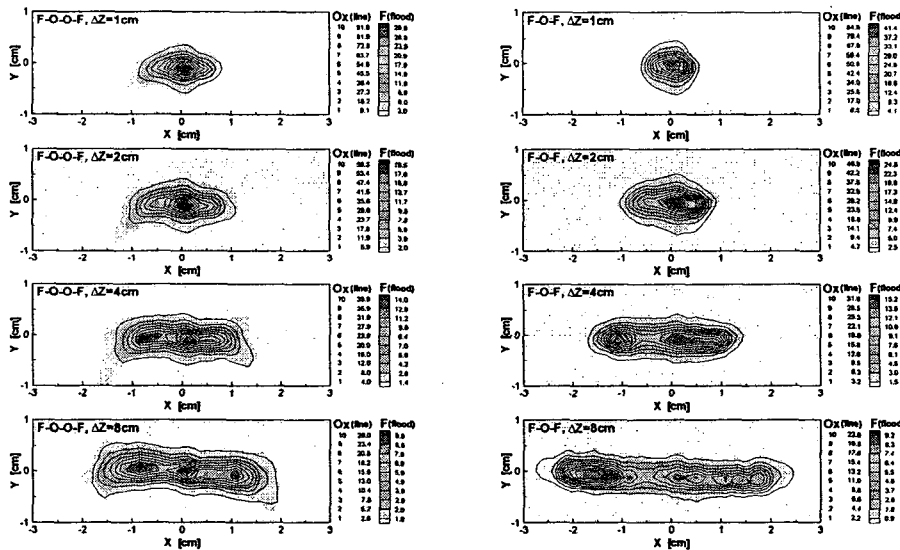

Seoul National University Rocket Propulsion Lab.

Mixing Efficiency



$$E_m = 1 - \frac{1}{n\bar{x}_o} \left[\sum_0^n (n\bar{x}_{o,i} + n\bar{x}_{y,i})(R-r) \right] - \frac{1}{n\bar{x}_y} \left[\sum_0^n (n\bar{x}_{o,i} + n\bar{x}_{y,i})(\bar{r} - R) \right]$$

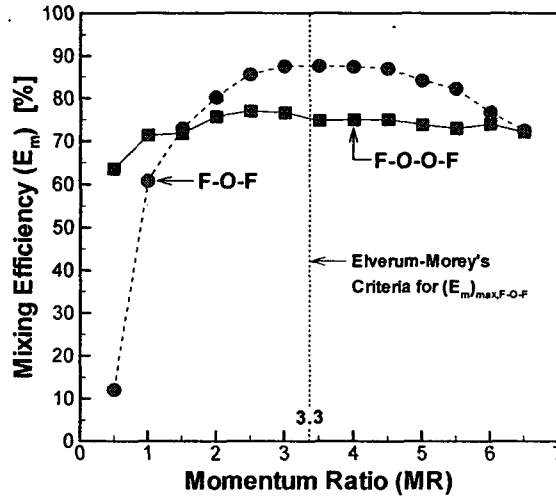

Seoul National University Rocket Propulsion Lab.

Model Gas Turbine Combustor

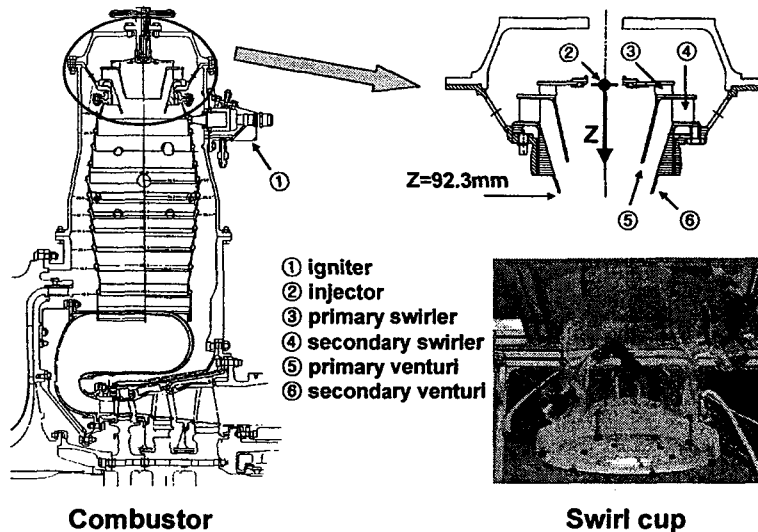

Combustor

Swirl cup

Seoul National University Rocket Propulsion Lab.

Relative Axial Mass Distributions

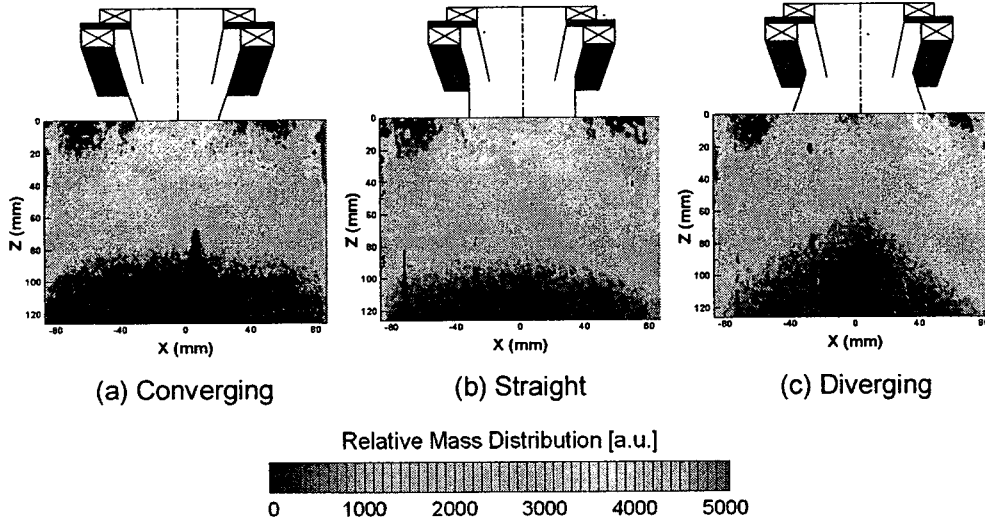

Seoul National University Rocket Propulsion Lab.

Simultaneous Measurement (Mass Distribution & Velocity)

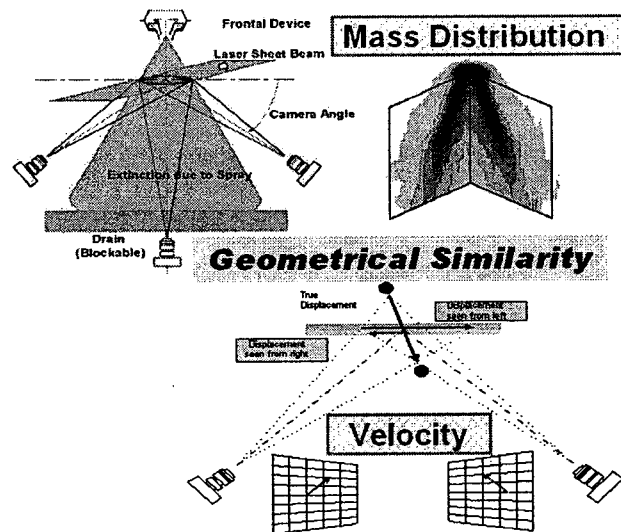

Seoul National University Rocket Propulsion Lab.



Part IV. Spray Visualization at High Ambient Pressure

Seoul National University Rocket Propulsion Lab.

Swirl Coaxial Injector Spray



❖ Breakup mechanism of swirl injector ❖ Liquid-liquid swirl coaxial injector

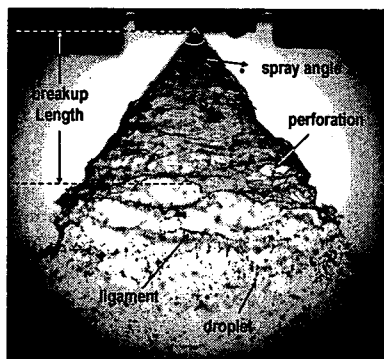

- Centrifugal force (thinning of sheet)
- Aerodynamic force

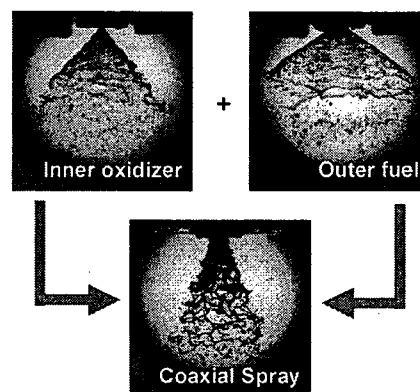

- Impact force (emulsion injection)

Seoul National University Rocket Propulsion Lab.

Spray in High Pressure

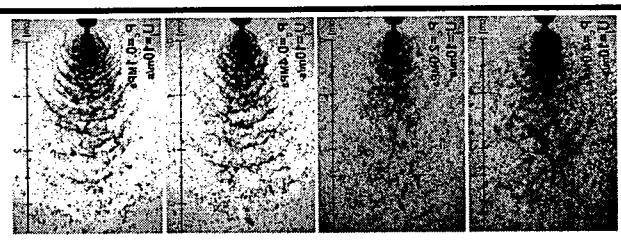

Increasing ambient gas pressure, P .

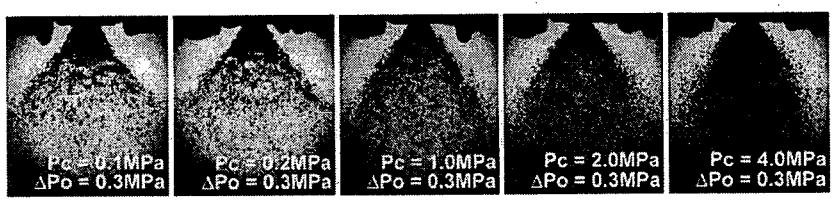

➔ In high pressure, spray become extremely dense.
Therefore, noise signals caused by error factors become strong.

Beer's Law



❖ Beer's law

$$G_k = G_{k-1} \exp[-\gamma_k L_k]$$

$$G_n = G_0 \exp[-\tau]$$

$$= G_0 \exp\left[-\sum_{k=1}^n \gamma_k L_k\right]$$

- G_0 : original intensity
- G_n : transmitted signal
- τ : optical depth
- γ : attenuation coefficient
- L : signal path

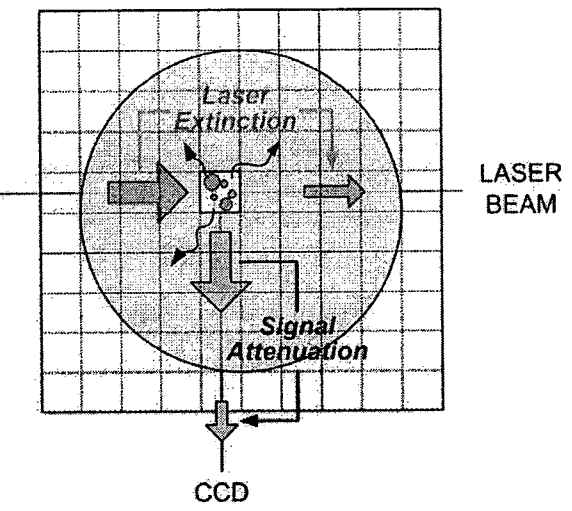
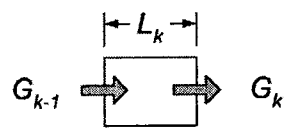

Laser & Signal Attenuation



❖ Laser Extinction

- Transmission (Tx) : measured by a photo detector

$$Tx = \frac{I_n}{I_0} = \exp\left[-\sum_{i=1}^n \gamma_i L_i\right]$$

Laser extinction

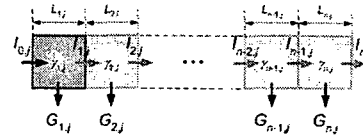

❖ Signal Attenuation

\tilde{G}_k : measured intensity by CCD

$$G_k = \tilde{G}_k \exp\left[\sum_{j=1}^{k-1} -\gamma_j L_j\right]$$

Signal attenuation

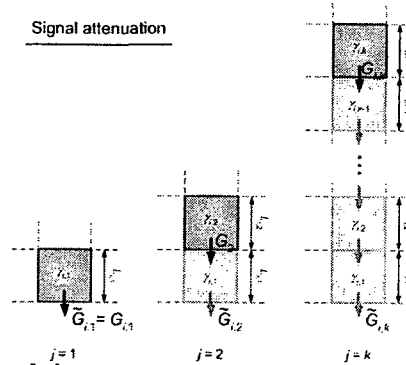

Mie-scattering Signal



❖ Mie-scattering Signal

- For large droplets ($D \gg \lambda$)

Lim and Sivatharu, 2002 (SETScan Optical Patternator)

$$- I/I_0 = \tau = \exp(-\kappa\Delta) = \exp(-\pi C_n D_{20}^2 \Delta/2)$$

$$\Rightarrow \gamma_k \propto ND_{20}^2$$

Mie scattered Light Intensity $\propto d^2$

$$G_{k,0} = c_s I_k \sum_i N_i D_i^2 = c_s I_k ND_{20}^2 \quad \text{where,} \quad D_{20} = \left[\sum_i N_i D_i^2 \right]^{1/2}$$

Experimental Setup for Test Experiment



- ❖ Experimental Setup for the atmospheric pressure circumstances
 - Solid cone spray (swirl in inside of injector): $Z = 25$ mm
 - Algebraic Reconstruction Technique (ART) : mentioned at the formal page.

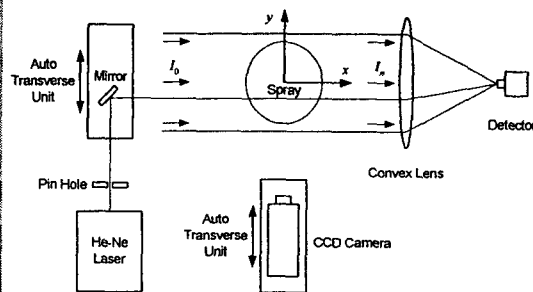
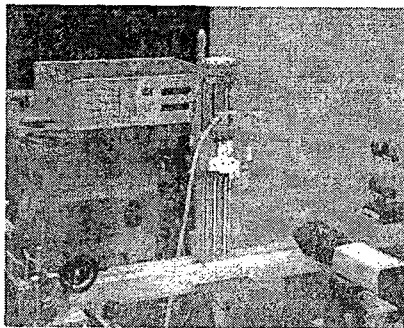

Seoul National University Rocket Propulsion Lab.

Mie-scattering Image Correction ($P_c = 1$ atm)



- ❖ Raw image reconstructed from line profile

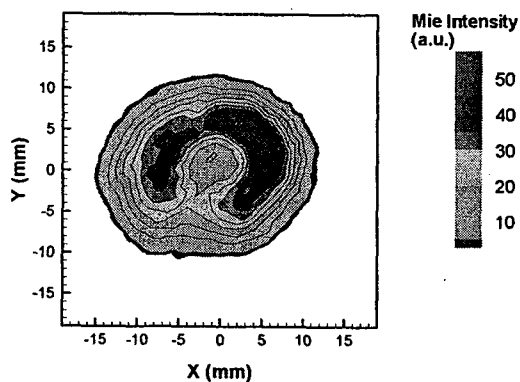

- ❖ Processed Image (attenuation corrected)

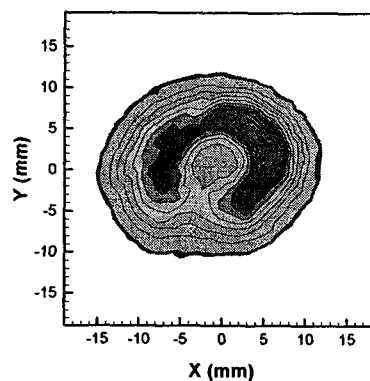

Seoul National University Rocket Propulsion Lab.

Patternation Index



❖ Patternation Index (P.I.)

$$P.I.(%) = \sum_{i,j} \left| \frac{1}{N} - \frac{r\mathcal{L}(i,j)}{\sum_{i,j} r\mathcal{L}(i,j)} \right| \times 100$$

❖ Spray Uniformity Index (S.U.I.)

$$S.U.I. = \sqrt{\frac{\sum_{i,j} (y(i,j) - \bar{y})^2}{N}}$$

where, $y \equiv \frac{r\mathcal{L}(i,j)}{\sum_{i,j} r\mathcal{L}(i,j)}$

$$\bar{y} \equiv \frac{\sum_{i,j} y(i,j)}{N} = 1$$

- N : # of grids
- m : mass of liquid or droplets (pixel Intensity in image)

— Seoul National University Rocket Propulsion Lab. —

Test Patternation Result



❖ Optical Patternator

Mie Image : Surface

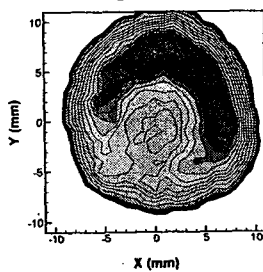

LIF Image : Mass

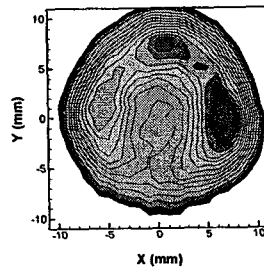

❖ Optical Line Patternator

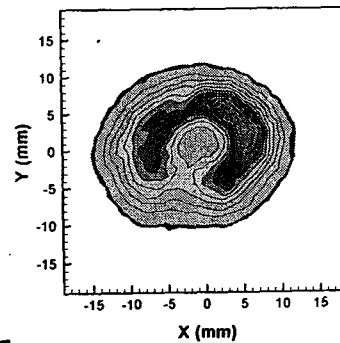

	Optical Line Patternator	Optical Patternator	
		Mie	LIF
P.I. (%)	50.49	50.21	48.02
S.U.I.	0.6030	0.5593	0.5456

— Seoul National University Rocket Propulsion Lab. —

Experimental Setup for High Ambient Pressure Condition

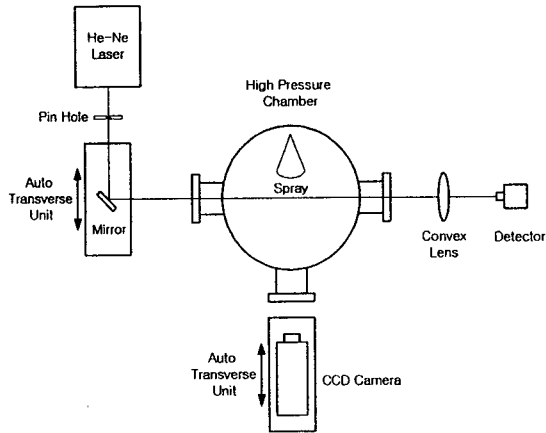
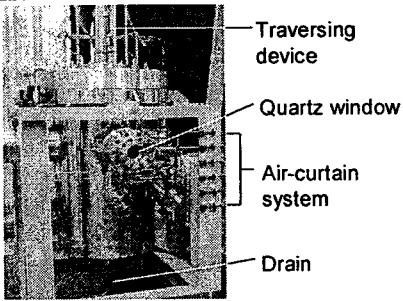

chamber diameter	500mm
window size	80mm×4
window material	quartz
operating limit pressure	6MPa
spray simulant	water
pressurizing gas	nitrogen

Seoul National University Rocket Propulsion Lab.

Experimental Condition



❖ Injector Parts

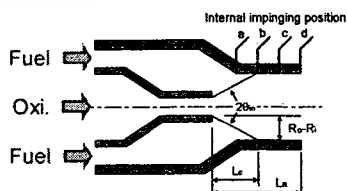
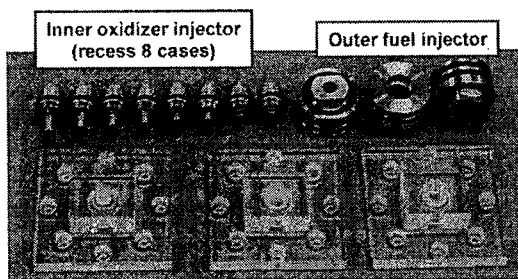

❖ Operating Conditions

Swirl Coaxial Injector
 - $d_0 = 1\text{mm}$
 - Oxidizer flow rate: 25.6 g/s
 - Fuel flow rate: 10.76g/s
 - $P_c = 1, 5, 10, 20, 40\text{bar}$
 - Round-edged inlet

Measurement position :
 $Z = 20\text{ mm}$ downstream
 From the end of injector

Seoul National University Rocket Propulsion Lab.

Patternation Results

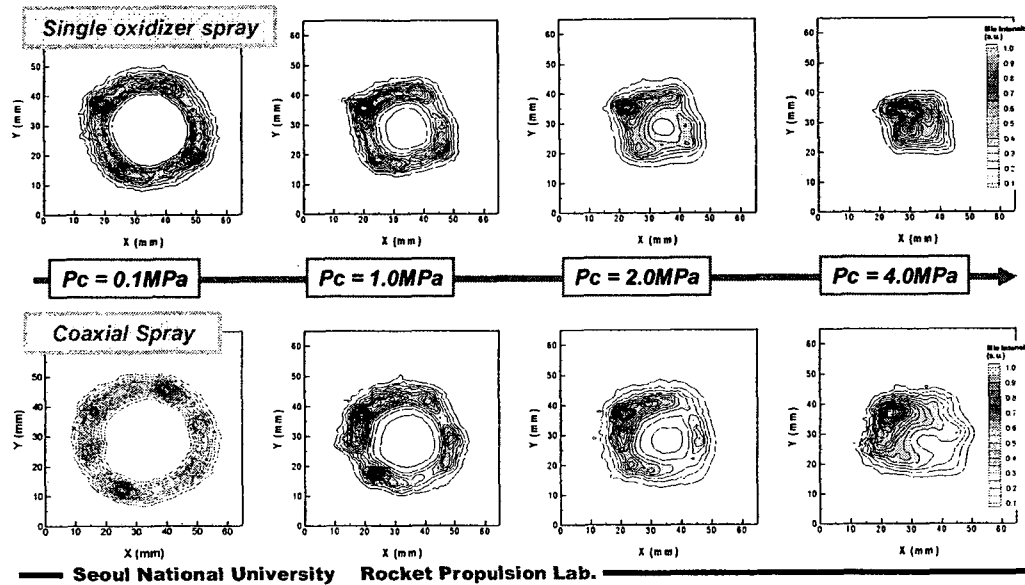

Seoul National University Rocket Propulsion Lab.

Conclusion



- ❖ **Optical Patternator can measure spray and flow parameters.**
 - Patternation, local mass distribution, drop size(SMD)
- ❖ **For quantitative measurement, the method for correcting signal extinction and determining correction factor, K must be considered.**
 - In order to correct the signal attenuation on the path through the dense spray, the method to find the geometric mean of the intensities obtained from the two cameras was evaluated.
- ❖ **Optical Line Patternator is a reliable diagnostics method for spray.**
 - Major error factors, laser extinction, signal attenuation can be corrected by Optical Line Patternator.

Seoul National University Rocket Propulsion Lab.