

A New Type of MR Sensor-Based Vehicle Detector with High Performance and Reliability

Moon-Ho Kang

Department of Control and Measurement Engineering, Sunmoon University, Asansi, Chungnamdo, Korea
(Tel : +82-41-530-2339; E-mail: mhkang@sunmoon.ac.kr)

Abstract: This paper proposes a vehicle detector with a magnetoresistive (MR) sensor. The detector consists of a MR sensor and mechanical and electronic apparatuses. Composed of six magnetically variable resistors, the MR sensor senses disturbance of the earth's magnetic field caused by a moving vehicle over itself and then produces an output indicative of the moving vehicle. Experiments have been carried out with three stages. At the first stage, the outputs of the sensor have been analyzed to show the validity of the detector's circuit and the detecting method. At the second stage, the detector has been tested on a local highway in Korea. Through the field tests, the outputs of the detector in response to various kinds of moving vehicles have been collected and analyzed. At the final stage, to verify the performance of the detector, traffic volumes on the highway have been measured with the detector and compared with the exact traffic volumes in a highly congested traffic.

Keywords: Vehicle detector, MR sensor, Earth's magnetic field, Traffic volume

1. INTRODUCTION

This paper proposes a new type of vehicle detector based on a magnetoresistive (MR) sensor, and addresses its characteristics and performance on the basis of experimental results. The detector consists of a MR sensor and mechanical and electronic apparatuses [1-3]. The MR sensor is composed of six magnetically variable resistors. Four of the resistors are shaped into a Wheatstone-bridge for sensing vehicles and biased with a dc voltage [3]. If resistance in one or more of the resistors is altered by the disturbance of the EMF caused by a moving vehicle over the sensor, the sensor produces an output indicative of the vehicle [4,5]. Mechanical apparatuses are built for sensor's mechanical stability, waterproof, and easy maintenance. Electronic apparatuses include sensor-output amplifiers, compensating circuits for the various local magnetic conditions adjacent to the detector, a flipping-current generating circuit, comparator circuits, and a microprocessor and a communication interface. Functions of these circuits will be described in the chapter 4 of this paper.

Experiments have been executed in three stages. In the first stage, the outputs of the sensor were analyzed thoroughly and the validity of the proposed compensating circuits and detecting schemes were confirmed. In the second stage, the proposed detector was tested on a local highway between Mishiryong and Sokcho in Korea. The results of the field tests show that the outputs of the detector take on different aspects according to the vehicle types. In the final stage, to show the performance of the detector, traffic volumes in a congested traffic situation were measured with the detector and then compared with the exact values.

2. STRUCTURE OF A MR SENSOR

The MR sensor, KMZ51, used in this research consists of six magnetically variable resistors which are made of a nickel-iron (permalloy) thin film deposited on a silicon wafer and patterned as resistive strips. All the resistors are packaged in a solid-state body as shown in Fig. 1 [3]. Biased with a dc

voltage (V_{cc}), an applied magnetic field changes the resistance of the permalloy. This change in the resistance causes a corresponding change in the output voltage of the resistor bridge ($+V_o -V_o$), which is termed the magnetoresistive (MR) effect. Fig. 2 shows the MR effect in the permalloy. Assume that, when no external magnetic field is present, the permalloy has an internal magnetic field (H_{in}), parallel to the current flow caused by the V_{cc} . If an external magnetic field (H_{ext}) is applied, parallel to the plane of the permalloy, the resultant magnetization vector of the permalloy will rotate by α to be a vector, H_{tot} . This makes the resistance (R) of the permalloy change as a function of the rotation angle, α , as follows:

$$R = R_0 + ? R_0 \cos^2 \alpha \tag{1}$$

where R_0 and $? R_0$ are material parameters.

During manufacture, the sensitive axis (or easy axis, the preferred direction of the external magnetic field, H_{ext}) is set to one direction along the length of the permalloy film. Magnetic field variation along the easy axis makes the maximum change in the resistance of the permalloy. When MR sensors are exposed to a magnetic disturbing field, the sensor elements are broken up into randomly oriented magnetic domains. In this case the output voltage of the sensor would not return to its normal level accurately and has a little offset. To restore the sensor's normal output, a large amplitude flipping current should be applied into a resistive strip ($+I_F -I_F$).

3. EXPERIMENTAL ANALYSIS OF A MR SENSOR

Fig. 3 shows the amplified outputs of a MR sensor (KMZ51) while a ferromagnetic object (magnet) moves over the sensor. In Fig. 3 (a), lower curve represents a sensor output while the magnet moves along the sensitive axis of the MR sensor (see Fig. 4(a)). As the magnet moves, the sensor output increases above an initial value, and then decreases to the same level as the initial value when the magnet is placed above the sensor, then decreases below the initial level. But, while the magnet moves perpendicularly to the sensitive axis

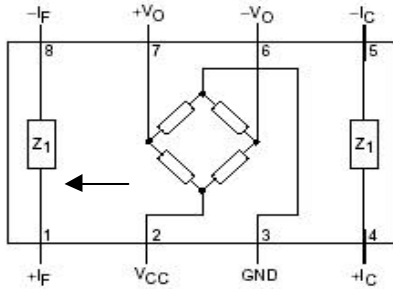

Fig. 1. Internal circuit of a KMZ51, where the arrow indicates the direction of the sensitive axis.

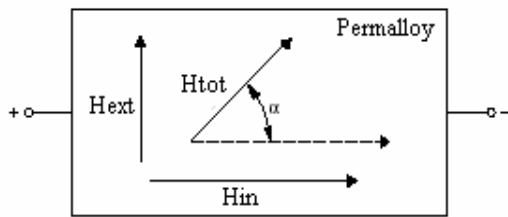
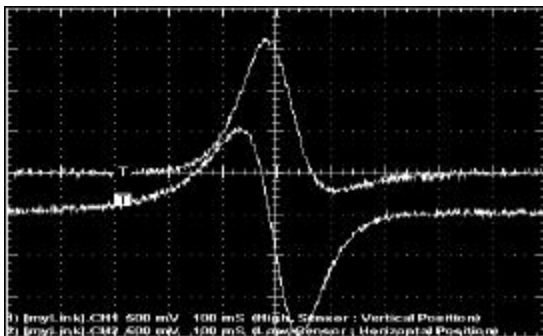

Fig. 2. Magnetostrictive (MR) effect of a permalloy, where H_{in} is an internal magnetic field, H_{ext} is an external magnetic field and H_{tot} is a resultant magnetic field.

of the sensor (see Fig.4 (c)), the sensor output is quite different from the lower curve (see the upper curve in Fig.3 (a)). Namely, when the moving magnet is placed directly above the sensor, the sensor's output increases to be the maximum and then decreases to the initial level. Also, it is shown that the upper curve (the case of the sensitive axis perpendicular to the moving magnet, see Fig.4 (c)) increases and decreases quite sharply than the lower curve (the case of the sensitive axis being along the moving magnet, see Fig.4 (a)). This sharpness can be a desirable effect on the discrimination of two closely and successively moving objects. Fig. 3 (b) shows the sensor's outputs in the case of reversing the moving direction of the magnet alternately, left to right, then right to left with the sensor centered. When the magnet moves perpendicularly to the sensitive axis (see Fig.4 (d)), the two successive sensor outputs are quite irrelevant to moving direction (see the upper curve), but in the case of moving along the sensitive axis (see Fig.4 (b)), successive sensor output is reversed according to the reversal of moving direction (see the lower curve).



(a) Amplified sensor outputs

(x : time, 100 [msec]/div. y : output, 500 [mV]/div.)

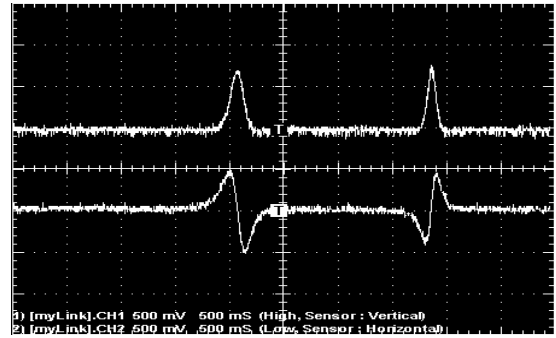

(b) Amplified sensor outputs with moving direction reversed alternately

(x : time, 500 [msec]/div. y : output, 500 [mV]/div.)

Fig. 3. Comparison of the amplified outputs of the MR sensors (KMZ51) while a magnet moves over the sensors. (upper curves in (a), (b) : moving perpendicularly to the sensitive axis, lower curves in (a), (b) : moving along the sensitive axis, see Fig.4.)

4. CONFIGURATION OF VEHICLE DETECTOR

Fig. 5 shows hardware configuration of the proposed vehicle detector. The vehicle detector consists of a MR sensor and mechanical and electronic apparatuses. The MR sensor used in this paper is described in the chapter 2. The flipping circuit in the Fig. 5 makes the flipping current and flows it through the compensating resistor in the MR sensor. Hardware includes circuits that make the detector's initial state stable at any adjacent environments. Because of the various local magnetic conditions of the detector's installation place, the outputs of the sensor are just different in quiescent condition. Furthermore, the outputs can be saturated to be not tunable if they are amplified monotonously without considering the local magnetic conditions around the detector. This is the most critical problem to be solved for the stable operation of the vehicle detector. After power-on of the detector, an initial adjusting process is carried out to make the amplified output of the sensor a constant predetermined value irrelevant to the various local magnetic conditions adjacent to the detector.

The sensor's output is amplified in two stages with Amp.1 and Amp.2 (see Fig. 5). The output of Amp.2 is used for vehicle detecting and initially tuned to be a constant predetermined value as mentioned above. An ad-converter, ADC, monitors the outputs of the Amp.2. Vehicle detecting algorithms are programmed in the microprocessor to count the volume of moving vehicles. In counting process a vehicle is simply detected with two comparators, Com1 and Com2, by comparing the output of the Amp.2 with two reference values. The microprocessor is equipped with a RS485 communication port and a flash memory to send the collected vehicle data to a local data-logger or to store them in the memory

5. FIELD EXPERIMENT

The developed detector has been tested on a local highway between Mishiryong and Sokcho in Korea. Fig. 6 shows a photograph of the experimental site. Tested field was set-up, firstly to measure the detector's output voltage waveforms for different moving vehicles. In multi-lane highway, a MR sensor

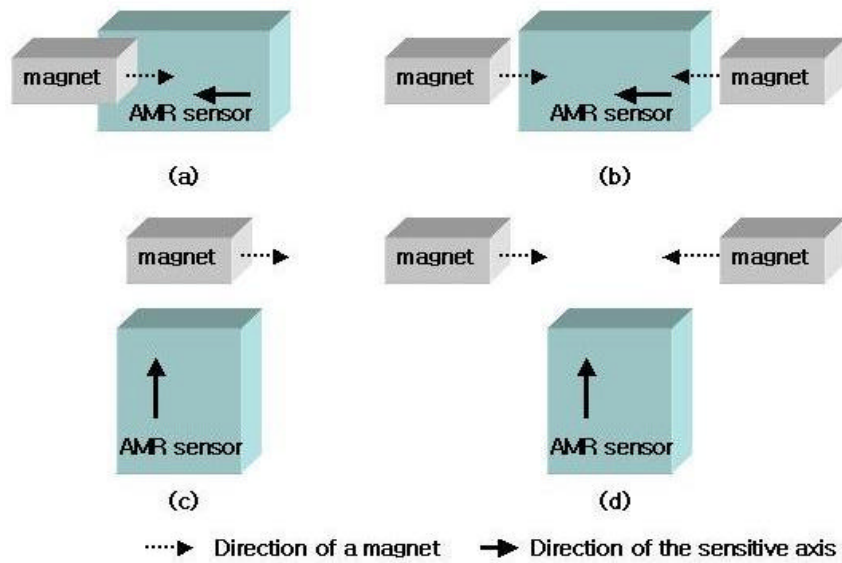

Fig.4. Arrangement of a magnet and an MR sensor for the experiments of the Fig. 3.

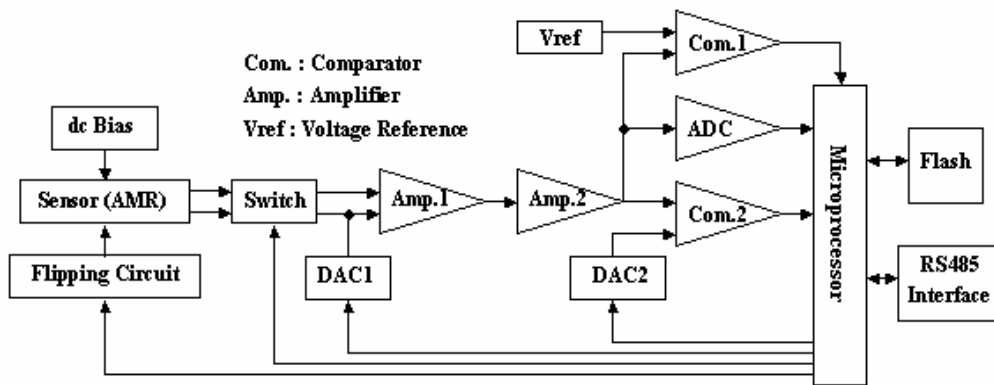

Fig. 5. Hardware configuration of a vehicle detector

in a vehicle detector buried in a lane could be affected with the ferromagnetic vehicles driving on other lanes, which gives incorrect information. Fig. 7 shows the detector's output curve when the sensitivity axis of the MR sensor in the detector is set along the moving direction of vehicles. In the figure, the second large and the third small hollows of the curve represent that detector's output are seriously interfered with the vehicles running on other lanes. In this case the detector may count a vehicle though there is no vehicle on its own lane, actually. The sensitivity of the MR sensor according to the distance is reduced deeply when the sensor's sensitive axis is perpendicular to the moving ferromagnetic object. Therefore, in this research experiments were accomplished with the sensor's sensitivity axis perpendicular to the surface of the road, namely, with the head of the sensitivity axis pointing to the vehicles moving on its own lane. With this arrangement any notable interferences, hollows of the sensor output as shown in the Fig. 7, were not found during the field test.

Fig. 8 shows the output curves of the vehicle detector according to the various vehicles driving over the detector on the highway. When a vehicle passes over the MR sensor in the detector, the sensor detects earth field variations caused by all the different dipole moments of the various parts of the

vehicle. Namely, the curves indirectly reveal a very detailed magnetic signature of the vehicle. From the curves of Fig. 8, it is shown that the outputs of the detector are substantially different from each other according to the types of the moving vehicles, such as, for example, sedans, vans, trucks, buses and special trucks.

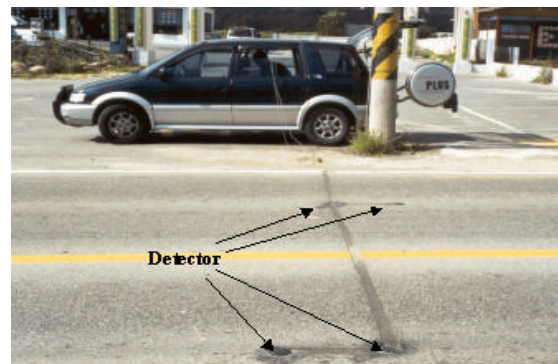
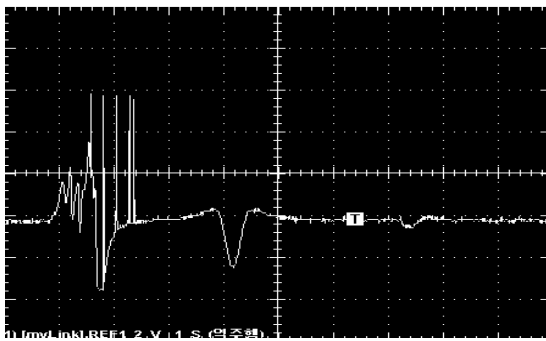
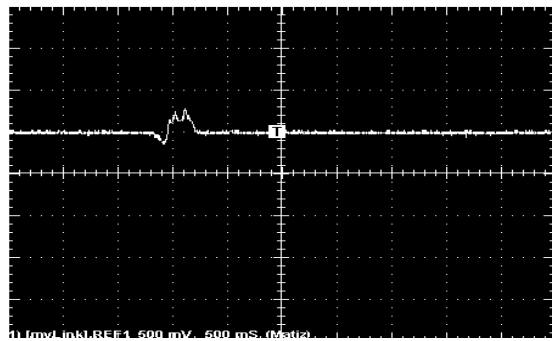

Fig. 6. Photograph of experimental site.



(x : time, 1 [sec]/div. y : output, 2 [V]/div.)

Fig. 7. Output hollows of the detector on a lane caused by the interferences with the vehicles driving on other lane. (The sensitive axis of the MR sensor is set along the moving vehicles. See Fig.4 (a))



(d) A light-weight passenger car

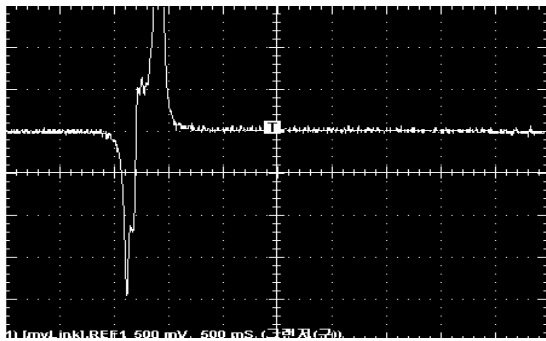

(a) A large size sedan

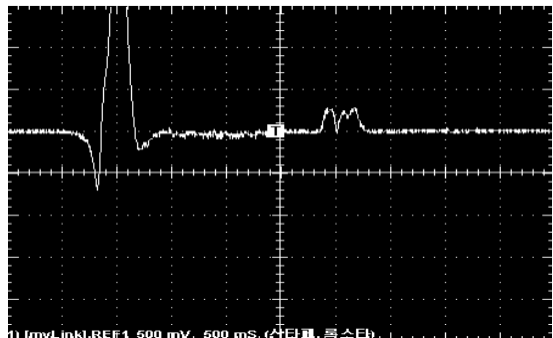

(e) Two RVs (van and jeep)

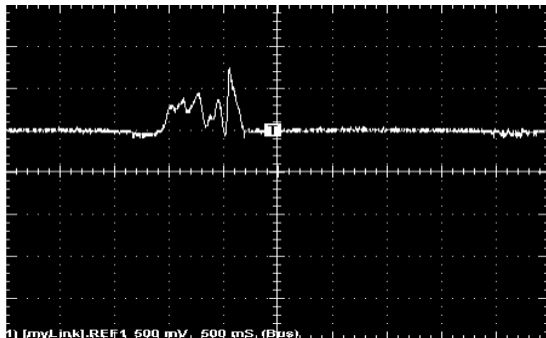

(b) A bus

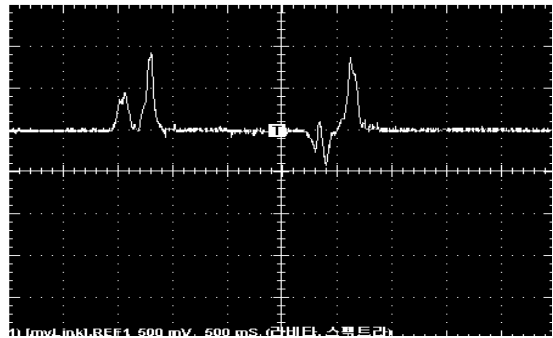

(f) A small size passenger car (hatchback) and a small size sedan

(x : time, 500 [msec]/div. y : output, 500 [mV]/div.)

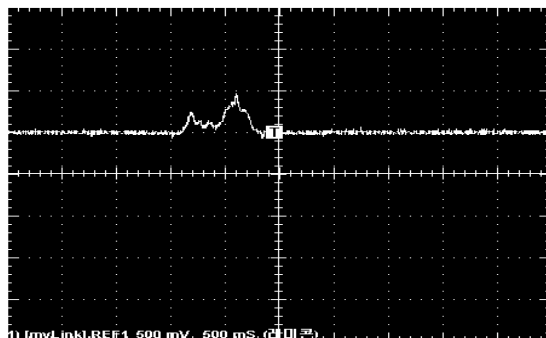

(c) A special truck (remicon)

Fig. 8. Output curves of the vehicle detector according to various vehicles driving over the detector on the highway.

Counting of a vehicle is simply realized by comparing the output of the detector (the output voltage of Amp.2) with the two reference values (see Fig. 5). Count and time-elapse data are updated for a new passing vehicle in the microprocessor and then sent to a notebook pc via a communication port.

Fig. 9 shows three experimental results obtained from a low speed congested traffic, about below 10 [km/h] averagely. Generally, vehicle detectors have the difficulty in discriminating between vehicles moving bumper-to-bumper in congested traffic and may count a larger number of vehicles than the exact number [6]. Three curves in the Fig.9 show the number of the vehicles according to the time-elapse on a lane of a local highway in Korea, Mishiryong to Sokcho. A ratio of the exact number of vehicles (set to 100) to the measured number of vehicles with the detector, exact-count/measured

-count, is noted under the each curve. Three curves show that counting error is 0.3% on average and proposed vehicle detector with a MR sensor has good performance in low speed traffic.

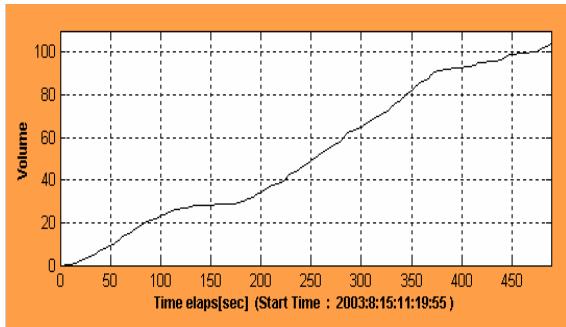

(a) exact-count/measured-count : 100/104

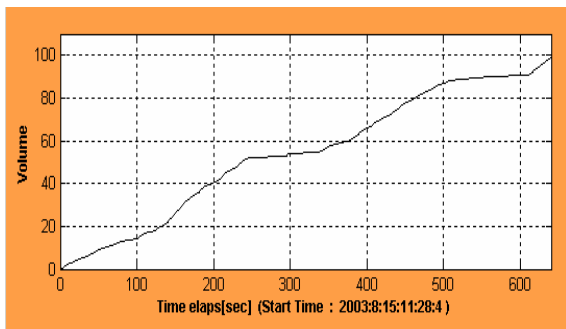

(b) exact-count/measured-count : 100/99

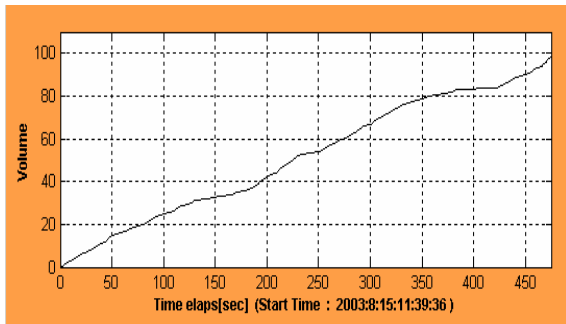

(c) exact-count/measured-count : 100/98

(x : time elapse [sec] y : vehicle volume [count])

Fig. 9. The number of passing vehicles (volume) according to the time-elapse on a lane of a local highway in Korea, Mishiryong to Sokcho,.

6. CONCLUSION

This paper proposes a new type of vehicle detector with a MR. Experimental analyses for characteristics of the sensor have done thoroughly, and the validity of the proposed compensation circuits and detecting methods were confirmed. The detector has been tested on a local highway between Mishiryong and Sokcho in Korea. Through extensive field tests, the output of the detector in response to various kinds of vehicles have been collected and analyzed. The analyses show that the outputs of the detector take on different aspects according to the vehicle type. The experimental results obtained from the low speed congested traffic show that the vehicle detector with a MR sensor has good performance in low speed traffic with counting error of 0.3% on average. Future research will be focused on the measuring of the vehicle speed.

REFERENCES

- [1] Michal Vopalensky, Pavel Ripka, Antonin Platil, Precise magnetic sensors, *Sensors and Actuators A: Physical*, Vol. 106, Issues 1-3, 15 September (2003) 38-42.
- [2] P. Ripka, M. Tondra, J. Stokes and R. Beech, AC-driven AMR and GMR magnetoresistors, *Sensors and Actuators A: Physical*, Vol. 76, Issues 1-3, 30 August (1999) 225-230.
- [3] Philips Semiconductors, General Magnetic field sensors, *Datasheet*, Jun 12, 1998.
- [4] M. H. Kang, Development of a traffic volume measuring device using AMR sensor, *Proc. of the KIEE Summer Annual Conf.*, Vol. D, Jeju, Korea, Jul., 2002, pp. 2385-2387.
- [5] Herry R. Sampey, Method and apparatus for analyzing traffic and a sensor therefore, *United State Patent*, Patent Number 5,877,705 Mar. 2, 1999.
- [6] J. I. Ko, A new loop detector for improving low speed performance, *Master's thesis*, Seoul Nat. Univ., Jan., 2000.