

압전소자를 이용한 음향 진동 박판에 대한 제어 기법

Reduction Method of Acoustic Vibrating Plate Using Piezo Electric Material

정도희*·박신옥**·김우영***

Dohee Jung , Seenok Park and Wooyoung Kim

Key Words : Corner-pinned Plates(코너 지지된 박판), Piezoelectric Actuator(압전소자).

ABSTRACT

Acoustic response control of a corner-pinned plate using piezoelectric wafers was studied, both theoretically and experimentally. Three different sizes of aluminum alloy plates were used and available ball joints were employed to hold the plate at the four corners. The plate with the largest aspect ratio showed the largest and most clear responses to the acoustic excitation in the range of frequencies (0~200Hz), and sound pressure levels (80~100dB) as predicted. The reduction of the acoustic response of the plate by piezoelectric actuator was very significant, more than expected, but abatement of the sound transmission through the plate was only slightly altered by the piezoelectric actuator. This work is an original work extending earlier work with doors excited by acoustic fields. The important difference is the used of ball joints to simulate the joints.

1. Introduction

As aircraft, automobile and other types of vehicles become faster, they make more noise as well as vibration. Noise and vibration can cause a very serious problem for the comfort of the passengers as well as structural fatigue problems [1]. Some of the serious noises can come from the mechanically induced vibration such as fretting that is periodical touching of parts. In this application, the plate and base part may accidentally touch since all sides of the corner-pinned plate are not supported between the joints. Fatigue is possible result of acoustic loading or vibration in general. It is aggravated by any physical damage which can trigger or exaggerate fatigues. Any types of four corner-jointed structures, like many of the doors of the vehicles, some of the surface plate parts of the vehicle bodies, or the covers of the machinery, etc. can be good examples where large response can occur, hence fatigue can occur.

The goal of this research was to reduce the vibration amplitude of a rectangular plate with corner supports caused by acoustic excitation by placing one piezoelectric actuator on the central position which has maximum deflection of plate. The range of the frequency and sound pressure level of the acoustic excitation was selected from the region of annoying noise environments. There is only a small amount of general literature on the vibration of corner-pinned plates [7, 11].

Analytical methods, kept as simple as possible, were used to size the panels, to design experiments, and to develop the controller concepts. It was also necessary to try to define plate frequencies to match the range of the speakers. It was necessary also to produce response large enough to be measured. These two opposing requirements drove the design. Three different sized rectangular plate models were used. Vibration control equipment was used to attempt to reduce the acoustic and mechanical responses of the vibrating plate. With these models, the frequencies and bending properties of the corner-pinned plates were calibrated, and finally, the control of the piezoelectric wafer was designed. A comparison of the experimental data with the theoretical results was also made.

* 신영중공업(주) 기술연구센터
E-mail : dhjung@syhico.com
Tel : (061) 462-3700, Fax : (061) 462-3709

** VOICEPIA

*** 조선대학교

2. Theoretical Analysis for the Vibration of a Corner-pinned Rectangular Plate

There are many different methods to get the natural frequencies of the corner-pinned plate vibration. Although the tradition PDE (partial derivative equation) method is valid here, the Rayleigh method was used more extensively here. The motion of rectangular plate was analyzed and then boundary conditions for the corner-pinned plate are applied to it [5]. The basic equation of motion for a vibrating rectangular plate:

$$D \nabla^4 w(x, y, t) + \rho_a \frac{\partial^2 w(x, y, t)}{\partial t^2} = 0 \quad (1)$$

where

$$D = \text{Flexible Rigidity} = \frac{Eh^3}{12(1-\nu^2)} \text{ (in-lb)}, \quad (2)$$

E = Young's Modulus (lb/in²),

h = plate thickness (in)

ν = Poisson' ratio

ρ_a = mass density per unit area (slug/in²)

t = time (sec)

w(x, y, t) = deflection (in)

$\nabla^4 = \nabla^2 \nabla^2$ (∇^2 = Laplacian operator)

For the free vibration, the motion is expressed as

$$w = W \cos(\omega t) \quad (3)$$

Substituting equation (3) into equation (1) yields

$$\begin{aligned} (\nabla^4 - k^4)W &= 0 \\ \text{where } k^4 &= \frac{\rho_a \omega^2}{D} \end{aligned} \quad (5)$$

By the theory of linear differential equations, the complete solution to (4) can be obtained by superimposing the solutions to the equations

$$\begin{aligned} (\nabla^2 + k^2)(\nabla^2 - k^2)W &= 0 \\ \nabla^2 W_1 + k^2 W_1 &= 0 \\ \nabla^2 W_2 - k^2 W_2 &= 0 \end{aligned} \quad (6)$$

Applying to equation (1) with the boundary conditions of a corner-pinned plate as equation (7), and from the Rayleigh's energy method for the frequency of mode shape 'i' [13], it yields,

$$\begin{aligned} w(0, 0, t) &= w(0, 0) = 0 \\ w(0, b, t) &= w(0, b) = 0 \\ w(a, 0, t) &= w(a, 0) = 0 \\ w(a, b, t) &= w(a, b) = 0 \end{aligned} \quad (7)$$

$$\omega_n = \frac{\lambda_i^2}{a^2} \sqrt{\frac{D}{\rho_a}} \text{ (cycle/sec) or } f_n = \frac{\omega_n}{2\pi} \text{ (Hz)} \quad (8)$$

Equation(8) is identical to the exact solution formula except for λ_i^2 (frequency parameter). The exact solution gives lower values in the lower modes.

The inclusion of ball joint mass, piezoelectric wafer mass stiffness will complicate the exact solution. By establishing a ratio between the Rayleigh solution (simple mode shape) and the exact solutions, this ratio can be applied to the plate frequency calculated by the Rayleigh method considering ball joint mass and inertia, and piezoelectric mass and inertia to obtain close prediction with test as equation (9). Also, the Rayleigh method is easier to use to design the original test setup.

$$\omega_n^2 = \frac{U_{plate} + U_{piezo}}{M_{plate} + M_{piezo} + M_{ball-joint}} \quad (9)$$

where

$$U_{plate} = \frac{D}{2} \iint_{plate} \left\{ \left(\frac{\partial^2 w}{\partial x^2} + \frac{\partial^2 w}{\partial y^2} \right)^2 - 2(1-\nu) \left[\frac{\partial^2 w}{\partial x^2} \frac{\partial^2 w}{\partial y^2} - \left(\frac{\partial^2 w}{\partial x \partial y} \right)^2 \right] \right\} dA,$$

$$U_{piezo} = \frac{D}{2} \iint_{piezo} \left\{ \left(\frac{\partial^2 w}{\partial x^2} + \frac{\partial^2 w}{\partial y^2} \right)^2 - 2(1-\nu) \left[\frac{\partial^2 w}{\partial x^2} \frac{\partial^2 w}{\partial y^2} - \left(\frac{\partial^2 w}{\partial x \partial y} \right)^2 \right] \right\} dA,$$

$$M_{plate} = \frac{(\rho_a)_{plate}}{2} \iint_{plate} w^2 dA,$$

$$M_{piezo} = \frac{(\rho_a)_{piezo}}{2} \iint_{piezo} w^2 dA,$$

$$M_{ball-joint} = 4 \left\{ (I_{xx} \cos^2 \theta + I_{yy} \sin^2 \theta) w_x^2 + (I_{xx} \sin^2 \theta + I_{yy} \cos^2 \theta) w_y^2 \right\}$$

where I_{xx} , I_{yy} is inertia moment of 4 ball joints at hinge point. θ is the inclined angle of ball joints and it is 45° . Fig. 1 shows that the difference of between 2 natural frequencies calculated with equation (8) and (9) is not small. Fig.2 shows the contour plot of solution for the 1st mode by Cheng's method.

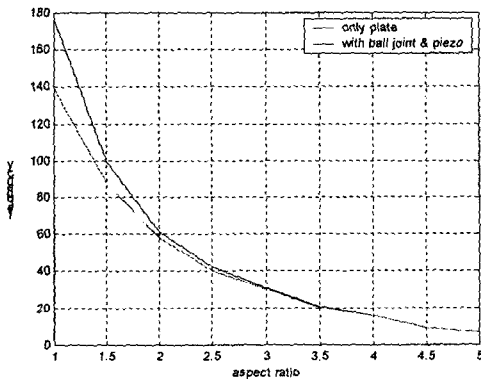

Fig. 1 Ball joint and piezoelectric sensor and actuator effect for the frequency responses at different aspect ratio

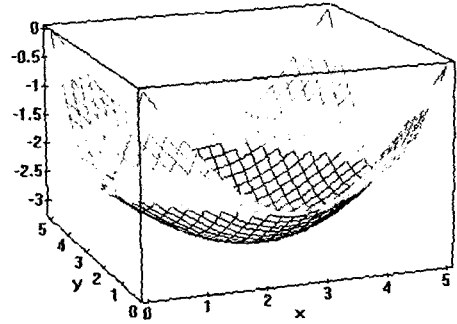

Fig. 2 Contour plots by Cheng's method

3. Experimental Setup

3.1 Corner-Pinned Rectangular Plate Model

The plate model is a thin rectangular plate of aluminum alloy (AL 2024) with a certain homogeneous thickness. This plate will be pinned at the four corners by ball-joints. On one side of the plate some strain gages will be attached to measure the deformation of the plate and on the other side piezoelectric wafers will be attached to control the deformation. This plate will be put on the open side of the anechoic box. The anechoic box is made of ply wood and anechoic material, and the one upper side of the box is open to accept the plate or plate frame. The anechoic material is put on the inner surface of the walls inside the box to provide a net pressure by avoiding acoustic over pressure, acoustic wave reflection and acoustic interference inside the box. Both outside of the box near the horn and inside the box, microphones will be placed to calibrate the sound wave before and after its transmission through the plate. Fig. 3 and Fig. 4 show the plate and anechoic box for the experiment.

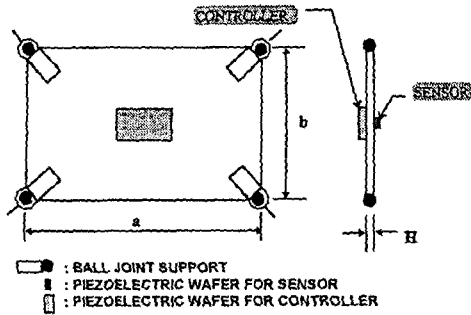

Fig. 3 Corner-pinned aluminum plate with piezoelectric sensor and piezoelectric controller

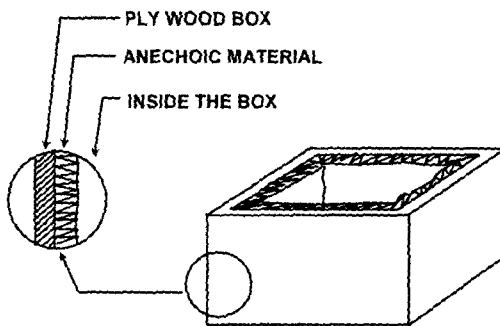

Fig. 4 Anechoic box

3.2 Acoustic Excitation Equipment

To provide acoustic excitation to the corner-pinned rectangular plate, a sound generating device will be used. The device is composed of a signal generator, a stereo amplifier, and a speaker (or drivers).

The signal generator provides a sinusoidal signal for the source of the sound wave. The frequency of the signal is tuned as closely as possible to the natural frequency of the rectangular plate for exciting resonant responses. The amplifier magnifies the amplitude of signal from the signal generator large enough to be used for exciting the plate. The amplified sound signal drives the speaker which excites plate with acoustic loading (pressure). The amplifier output to the speaker required adjustment at the different frequencies to keep the same sound level, because the amplifier does not provide the

constant output. The size of anechoic chamber is $30 \times 15 \times 12$ (in³).

The speaker (or driver) provides sound wave levels of 80dB, 90dB and 100dB to the plate. Also, 12 inch dial-wound voice coil type subwoofer speaker was selected to provide a low frequency sound wave of 50 ~ 200Hz because the natural frequency of the corner-pinned plate chosen was in that range. The frequency range of speaker is 26Hz ~ 2.7kHz, and impedance is 8ohm/4ohm. For this reason, low frequency speaker or woofer is used as the acoustic driver as shown in Fig. 5.

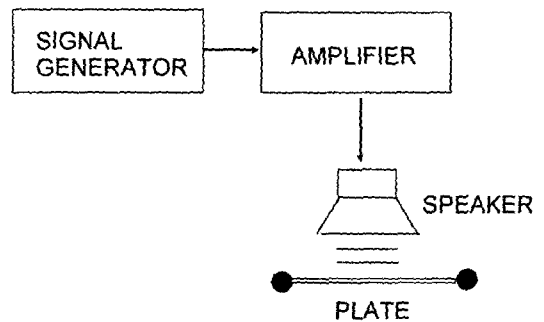

Fig. 5 Acoustic equipment

3.3 Vibration Control Equipment

The control equipment was intended to abate the vibration of the plate itself and to reduce the transmission of the sound wave through the plate. It consists of three parts: a sensor, a controller, and a piezoelectric actuator as shown Fig. 5. The sensor part is made of one piece of piezoelectric wafer attached to the surface of the plate. This piezoelectric obtains information regarding the plate deformation. The information from piezoelectric sensor is sent to piezoelectric power amplifier and then to piezoelectric actuator to allow the response to be snubbed. Practically, it will show the points of maximum strain and those points which are optimum for the location of control piezoelectric wafer. The outcome of this information is to provide the key to the controller to

control the piezoelectric actuator and to show how much the deformation is reduced by the actuators.

The controller part receives the information from the sensor and uses it to give appropriate amount of electric voltage to the piezoelectric actuators. The controller (power amplifier of piezoelectric actuator) is fixed at a certain magnification value. The piezoelectric actuator is placed on the surface of the plate. These piezoelectric wafers apply strain by the electric power sent by the controller, and its bending moments are proportional to the amount of the electric power. The bending motion of these wafers is used to oppose the bending of the vibrating plate. The optimum points of the actuators on the plate can be decided either theoretically or experimentally. The optimum locations are different according to the mode shapes of the vibration. The following discussion will be limited to one mode shape-"mode 1".

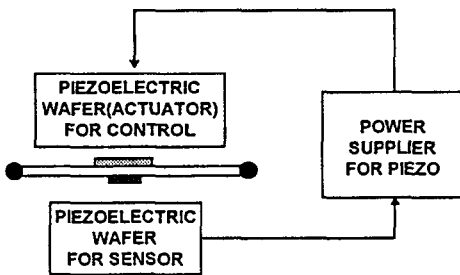

Fig. 6 Three major parts of the control equipment

3.4 Control Method for Reducing the Response of the Plate By Using a Piezoelectric Actuator and Piezoelectric Sensor

There can be different methods for controlling the vibration responses of the plate. When it comes to vehicles such as aircraft, weight is a major concern. The required equipment should be constructed as light as possible. Standard force devices can be used to control response but they tend to be heavy. Piezoelectric devices,

amplifier, and power source are light and thus used here. For controlling the responses of the corner-pinned plate, a small piece of piezoelectric wafer was used as an actuator. Also, a small piece of piezoelectric wafer was used as a sensor. While it was originally intended to use strain gages, this was unsuccessful. Solder joints failed and the gages disbonded. Lack of skill in using strain gages also contributed. Below is the diagram for the control logic.

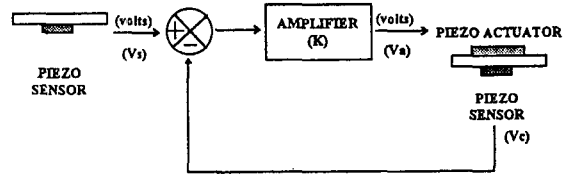

Fig.7 Block diagram for the feedback piezoelectric control concept

The feedback gain of the signal from the piezoelectric sensor to the piezoelectric control wafers is :

$$V_c = \frac{KV_s}{1 + KV_s} \quad (10)$$

The central points for locating the piezoelectric control wafer and piezoelectric sensor wafer and their orientation are the same for the best efficiency. The points of the largest strains or bending moments of the plate were selected [13]. Based on the simple mode shape the piezoelectric wafer was placed at the center of the plate and in the x-direction. Reliable bending moment responses from the piezoelectric sensor were obtained. Since the strain is proportional to the bending moment of the plate, the bending moment responses were relied on as the strain responses with some proportional factors.

4. Results

According to the results of the theory and experiments, it is recognized that the influences of the ball joints and the piezoelectric wafer on the plate vibration were significant for the smaller aspect ratios, with influence diminishing as the aspect ratio increased. The piezoelectric actuator mass influence was only slight. Its added mass was offset by added stiffness. The piezoelectric sensor was not taken into consideration because its influence would be much smaller than piezoelectric actuator.

For the response analysis, the simple mode shape and the Cheng's mode shape were used [13]. The simple mode shape was believed to be somewhat less accurate for the large aspect ratios. Cheng's mode shape, however, were believed to be more representative solutions for the vibration response of the plate. Table 1 shows comparison results of natural frequencies. The reason of error assumed to be caused by damping of plate, piezoelectric sensor and controller, and friction of ball joints.

Table 1. Comparison of natural frequencies

Aspect ratio	Theory (Hz)	Experiment (Hz)
1.0	176.84	140
1.5	101.49	110
2.0	60.51	70

Fig.8 shows the speaker response characteristics to the frequency for the different input levels. Fig.9 shows comparison of sound levels between the transmitted sound through the plate and the direct sound from the speaker for sound level 80dB.

As shown in the Fig. 10, the plate of the aspect ratio 2.0 gave the most significant responses, and the responses of the plate are not linear to the sound pressure level. They each showed different peaks, but the normalized graphs more closely follow the theoretical analysis.

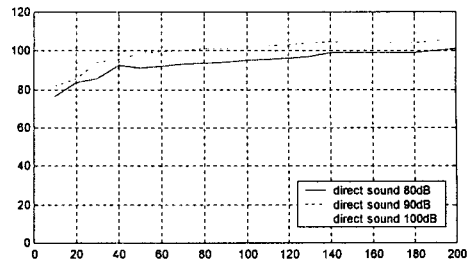

Fig.8 Speaker response characteristics

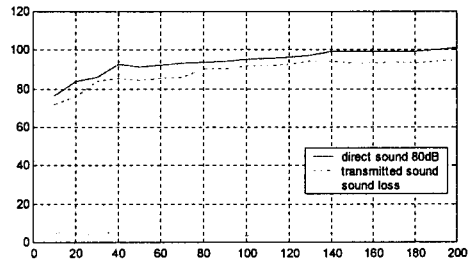

Fig.9 Comparison of sound levels

With the piezoelectric actuator, the responses were lower by about 76% down to about 24% of the original ones. The piezoelectric sensor for the control worked well as a sensor (See Fig.11). The frequency responses are not constant with different dB levels, nor are they linear with pressures. The piezoelectric wafer worked well as a control actuator for reducing vibration responses as expected.

The transmission of the sound through the plate was not high, and the reduction improvement with the piezoelectric actuator was only slight. However, more accurate noise measurements are needed to better quantify the effects. It was measured more closely predicted from the preceding experiments [7] perhaps because they used better measuring equipment. Since the bending responses of the plate of aspect ratio 2.0 is the most significant of the three different sizes of plates, these data and graphs are presented here, while the related data for all aspect ratio is in [13]

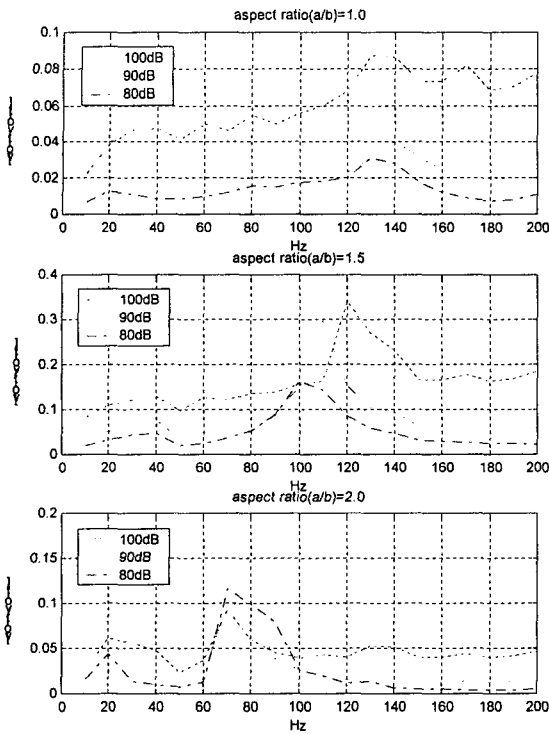

Fig.10. Comparison of normalized response of piezoelectric sensor to the sound excitation

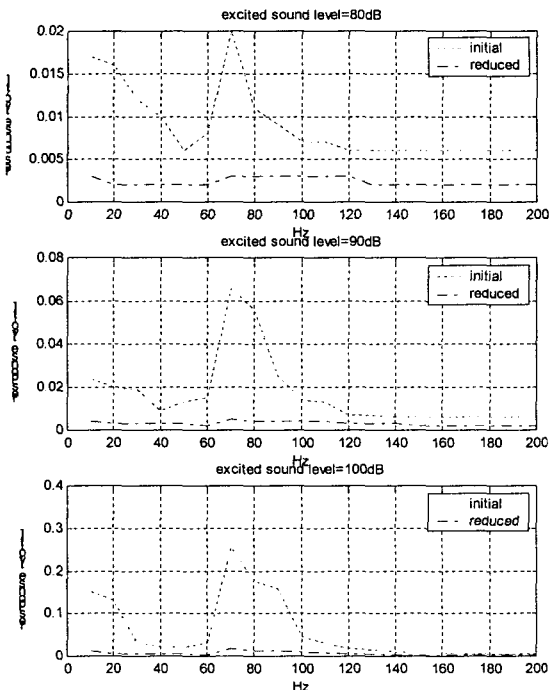

Fig. 11. Comparison of the responses with and without the piezoelectric actuator (aspect ratio = 2.0)

5. Conclusions

It was found that a small piezoelectric wafer, used as a motor could snub acoustic response of corner-pinned plates of sizes 5×5 , 5×7.5 , 5×10 (in \times in) and 0.063(in) thickness. The responses were snubbed by around 74% typically at resonance (or some overall averages). While it was hoped that this snubbing action would alter the acoustic transmission somewhat, the results showed that the acoustic transmission was only slightly altered. However, more accurate measuring devices may have conclusively obtained the reduction difference. The wafer was placed only on one side of the plate. Two wafers may have given more reductions. A second, much smaller piezoelectric wafer, was used as a sensor in feedback plate motion to the control system, then to the motor to snub. Attempt to use strain gages were unsuccessful. The strain gage wire leads disbanded, the strain gage became detached, and a variety of these problems led to using the second smaller wafer that worked well. Frequency correlation, amplitude, strains, and bending moments were close to the original predictions and remained similar throughout all tests. This results from a careful, well planned, and accurate theoretical and experimental approach.

Recommendations for the future work are,

- to improve and optimize the piezoelectric wafer size, power levels, weight etc., or prove that this was optimum
- to employ stain gages (lighter than piezoelectric wafer) as sensors
- to explore other plates, both metal and composites
- to improve the ball joints

- e) to develop high noise levels using multi speakers or air source modulators
- f) to develop capability more accurate vibration property analysis or transfer functions and frequency & damping analysis, and transient analysis to obtain frequency and damping, possible use LabVIEW program to this.

Acknowledgement

The authors would like to acknowledge that this work was supported by Brain Korea 21.

References

1. E. J. Richards and D. J. Mead, 1968, *Noise and acoustic fatigue in aeronautics*, London, New York Wiley.
2. K. D. Kryter, 1968, *The effects of noise on man*, New York, Academic Press.
3. Michael J. T. Smith, 1989, *Aircraft noise*, Cambridge, New York, Cambridge University Express.
4. L. F. Yerges, 1969, *Sound, noise, and vibration control*, New York, Van Nostrand Reinhold Co..
5. Leissa, *Vibration of plates*, NASA SP 160.
6. L. Cremer and M. Heckl, 1973, *Structure borne sound-structural vibrations and sound radiation at audio frequencies*, Berlin, New York, Springer-Verlag.
7. S. Akishita and H. Lee, 1990, "Sound Transmission Control by Using Piezo-electric Actuator", AIAA 90-3923.
8. Robert E. B., *Formulas for natural frequency and mode shape*, Robert E. Kryger Publishing Company.
9. Robert E. R. Jr., 1965, *Comparison of methods in calculating frequencies of corner-supported rectangular plates*, NASA TND 3030.
10. Harris and Crede , *Shock and vibration handbook*, Mc Graw-Hill Book Company.
11. X.-S. Cheng, *Vibrations of rectangular plates supported at corner points*, Tongji University, Shanghai.
12. T. Baumeister, and L. S. Marks , *Standard Handbook for Mechanical Engineers*, Mc Graw-Hill Book Company.
- 13 S. Park, 1994, "Techniques for Damping Acoustic and Vibration Responses of Rectangular Corner-pinned Plates Using Piezoelectric Actuators", *M.Sc. thesis of Saint Louis University*.