

# Development of a Hydrogen Peroxide Rocket Engine Facility

Ahn Sang-Hee, S. Krishnan, and Lee Choong-Won  
School of Mechanical Engineering  
Kyungpook National University, Taegu-702 701, South Korea  
[chwlee@knu.ac.kr](mailto:chwlee@knu.ac.kr)

*Keywords: Hydrogen peroxide propulsion, Monopropellant Rocket*

## Abstract

The ongoing developmental studies on the application of hydrogen peroxide for propulsion are briefly reviewed. A detailed design-study of a laboratory scale facility of a hydrogen peroxide mono-propellant engine of 100-N thrust is presented. For the preparation of concentrated hydrogen peroxide, a distillation facility has been realized. Results of water analogy tests are presented. Initial firings using the concentrated hydrogen peroxide were not successful. Low environmental temperature, low contact area of the catalyst pack, and contamination in the hydrogen peroxide were considered to be the reasons. Addressing the first two points resulted in successful firing of the rocket engine.

## Introduction

In recent years, there has been a renewed interest in the use of hydrogen peroxide ( $H_2O_2$ ) as an oxidizer in bipropellant liquid rocket engines as well as in hybrid rocket engines.<sup>1-4)</sup> This renewed interest is because of the growing importance in using propellants of low toxicity and enhanced versatility. The use of  $H_2O_2$  in rocket propulsion offers the versatility of operating the engine on a dual mode: a bipropellant mode (either as a bipropellant liquid engine or as a hybrid rocket engine) for a large thrust requirement and a monopropellant mode for a small thrust application. A propulsion unit without a requirement for a separate ignition unit offers a higher system-reliability.  $H_2O_2$  decomposes into a mixture of superheated steam and oxygen to a temperature of around 1000K. This leads to automatic ignition either with a liquid fuel in a bipropellant engine or with a solid fuel in a hybrid-rocket engine. Thus, the versatility with the additional advantage of automatic ignition makes the "green"  $H_2O_2$  an attractive oxidizer.

## Ongoing Developmental Projects

Many developmental studies are in progress around the world in adopting  $H_2O_2$  in rocket propulsion. These studies are towards developing  $H_2O_2$ -oxidized bipropellant liquid engines (mostly having kerosene as the fuel) and hybrid rocket engines.

The  $H_2O_2$ -oxidized hybrid rocket engines are actively being considered for application in upper stage propulsion. In 1999, NASA awarded a contract to Lockheed Martin Astronautics, along with

subcontractors Boeing Rocketdyne and Thiokol, to begin development of a  $H_2O_2$ -oxidized hybrid motor for upper stage application in reusable launch vehicles and emerging defense applications.<sup>5-7)</sup> The hybrid upper stage propulsion system uses a hockey-puck-shaped, single end burning fuel grain that is slightly oxidized to enhance regression rate and system operability. High concentration (>90%)  $H_2O_2$  is passed through a catalyst pack and aft-mounted injector, which directs the oxidizer toward the face of the fuel grain in a swirling pattern. In 2001, at NASA Stennis the static firings of these 280- and 610-mm-diameter motors demonstrated auto-ignition, stable and efficient combustion, extinguishment, and restart of the propulsion system. A follow-on effort at an increased scale is reported to be under consideration.<sup>7)</sup>

For decades, launch vehicles have accommodated small "piggyback" spacecraft — secondary payloads. But, most of these secondary payloads do not have any means of changing orbits once deployed from their host launch-vehicle. Therefore there is a widespread need for small and inexpensive propulsion and guidance modules that can boost small secondary payloads from their drop-off orbits to more desirable orbits. SpaceDev has been awarded in August 1999 a contract to develop the propulsion and guidance modules using the  $H_2O_2$ -oxidized hybrid-rocket concept. The micro-kick hybrid motor under this concept is storable, restartable, throttleable, modular, and scalable. It is about 130-mm diameter and 305-mm length with a total thrusting time of about 45s. Using the knowledge gained by several test firings of this motor, SpaceDev has begun development of larger, reusable motors in the 45- 67-kN-thrust class.<sup>7, 8)</sup> ONERA in France is working on the development of  $H_2O_2$ /polyethylene or HTPB hybrid-propulsion system for 100-kg micro-satellites and small tactical missiles.<sup>8, 9)</sup>

Aerojet has successfully developed a trifluid propellant injector for  $H_2O_2$ -kerosene reusable bipropellant engines.<sup>10)</sup> And, Boeing Rocketdyne is developing  $H_2O_2$  catalyst packs and  $H_2O_2$ /kerosene torch igniters for possible applications in orbital maneuvering systems, crew escape systems, and all upper stage and on-orbit applications requiring lower life-cycle costs and improved safety.<sup>10)</sup>

## Engine Design

For the present study a laboratory scale rocket engine is to be designed for a thrust of 100N. The engine uses H<sub>2</sub>O<sub>2</sub> of >90% concentration. The thrusting time is to be in excess of 10 seconds. The nozzle entry stagnation pressure = 2 MPa and the nozzle pressure ratio = 15. The calculated theoretical-performance values for the engine are as given in Table 1.<sup>(11)</sup>

For the decomposition of H<sub>2</sub>O<sub>2</sub>, catalysts are used and the catalyst systems are basically of three types: 1) liquid-liquid, 2) pellet bed, and 3) screen bed.<sup>(2, 3, 12)</sup> The screen bed system is found to be the most effective one. There are two important parameters for the design of a screen bed: 1) the average mass flux through the bed (the so called bed-loading) and 2) the average residence time. Among the screen bed systems, pure silver screen is found to be most effective one. Adopted values of mass-flux in proven beds of silver screen vary from 117- to 280-kg/m<sup>2</sup>-s.<sup>(12-15)</sup> Average residence time in the catalyst bed varied from 0.7ms to 1.5ms.<sup>(13-16)</sup>

Generally the quality factor for  $c^*$  (or  $c^*$  efficiency) is taken as 0.95 for bi-propellant liquid engines and solid propellant motors. Since the engine under consideration is a monopropellant one and the

quality of combustion is very much dependent on the catalyst, a conservative value of 0.90 is assumed for the quality factor. Therefore, estimated experimental  $c^*$ ,

$$c_{\text{expt}}^* = 940 \times 0.9 = 846 \frac{\text{m}}{\text{s}} \quad (1)$$

$$C_{T_{\text{sea level}}} = 1.338 + \frac{A_e}{A_t} \left( \frac{p_e}{p_{0n}} - \frac{p_a}{p_{0n}} \right) = 1.3808 \quad (2)$$

Assuming a quality factor for the thrust coefficient as 0.95

$$(C_{T_{\text{sea level}}})_{\text{expt}} = 1.3117 \quad (3)$$

$$(I_{sp_{\text{sea level}}})_{\text{expt}} = 1.3117 \times 846 = 1109.7 \frac{\text{N-s}}{\text{kg}} \quad (4)$$

Propellant flow rate,

$$\dot{m}_p = \frac{100}{1109.7} = 0.09013 \frac{\text{kg}}{\text{s}} \quad (5)$$

**Table 1 Theoretical rocket performance characteristics of the hydrogen peroxide engine assuming frozen composition**

CHEMICAL FORMULA	WT FRACTION		ENERGY CAL/G-MOL	STATE	TEMP DEG K	
FUEL H	2.00000	O 2.00000	0.900000	-44880.000	L	298.15
FUEL H	2.00000	O 1.00000	0.100000	-68317.400	L	298.15

	CHAMBER	THROAT	EXIT
$p/p_e$	1.0000	1.8188	15.000
$p$ (MPa)	2.0	1.01	0.133
$T$ (K)	1029.54	906.39	559.65
$\bar{m}$ (kg/kgmol)	22.105	22.105	22.105
$\gamma$	1.2648	1.2764	1.3158
$\mu$ (kg/m-s) $\times 10^4$	0.42755	0.38113	0.23851
$c_p$ (J/kg-K)	1796.6	1737.1	1567.1
PRANDTL NUMBER	0.8256	0.8421	0.8880
$A_e/A_t$		1.0000	2.6713
$c^*$ (m/s)		940	940
$C_T^0$		0.702	1.338
$I_{sp_{\text{vac}}}$ (N-s/kg)		1176.5	1424.9
$I_{sp_{\text{sea level}}}$ (N-s/kg)		1128.9	1297.7
$u_e$ (m/s)		659.7	1257.5

MOLE FRACTIONS		
H2O	0.70757	O2 0.29243

PRODUCTS WHICH WERE CONSIDERED BUT WHOSE MOLE FRACTIONS WERE LESS THAN 0.50000E-05 FOR ALL ASSIGNED CONDITIONS  
H; HO2; H2; H2O2; O; OH; O3; H2O(S); and H2O(L)

An average mass-flux of  $200\text{kg/m}^2\text{-s}$  is assumed for the engine. Therefore, the cross-sectional area of the catalyst bed,

$$A = 4.5063 \times 10^{-4} \text{ m}^2 \quad (6)$$

$$\Rightarrow D = 0.02395 \text{ m (say, 25mm)}$$

Combustion chamber temperature,

$$T_0 = 1029.4 \times \sqrt{0.9} = 976.6 \text{ K} \quad (7)$$

Combustion chamber gas-density,

$$\rho = \frac{2 \times 10^6}{(8314.3/22.105) \times 976.6} = 5.445 \frac{\text{kg}}{\text{m}^3} \quad (8)$$

Combustion-chamber-gas velocity,

$$u = \frac{0.09013}{(\pi/4) \times 0.025^2 \times 5.445} = 33.72 \text{ m/s} \quad (9)$$

For the assumed residence time of 1.5ms, the catalyst-bed length,

$$L = 33.72 \times 0.0015 = 0.0506 \text{ m} \quad (10)$$

$$\Rightarrow \text{say } 55 \text{ mm}$$

#### Injector Orifice

To effectively de-link the feed system from the engine, generally about 0.6MPa or 10 percent of the chamber pressure, whichever is higher, is provided at the propellant injector. Therefore, a pressure drop of 0.7MPa is provided for the propellant injection. For the mass flow-rate of  $0.090 \text{ kg/s}$ , assuming the coefficient of discharge for the orifice as 0.8, the orifice diameter is calculated as  $1.8 \text{ mm}$ . As the variation of propellant-injection characteristics are to be considered for the study of engine performance, different orifice diameters from 1.4 mm to 2 mm in steps of 0.2 mm are selected.

#### Nozzle Dimensions

The mass flow-rate through the choked nozzle is given by,

$$\dot{m} = \frac{p_0 n A_t}{c_{\text{expt}}} \quad (11)$$

$$A_t = \frac{0.09013 \times 846}{2 \times 10^6} = 3.8125 \times 10^{-5} \text{ m}^2 \quad (12)$$

$$\Rightarrow D_t = 6.97 \text{ mm} \quad \text{say } 7 \text{ mm}$$

$$D_e = \sqrt{2.6713 \times 7} = 11.44 \text{ mm} \quad (13)$$

A half-cone angle of  $13^\circ$  is selected for the nozzle.

#### Propellant Tank Pressure

For the mass flux of  $200 \text{ kg/m}^2\text{-s}$ , the pressure drop across the catalyst bed is expected to be about 0.85

MPa.<sup>12)</sup> Therefore the pressure upstream of catalyst bed =  $2.0 + 0.85 = 2.85 \text{ MPa}$ . With the pressure drop of 0.7MPa across the injector orifice and 0.2MPa across the solenoid valve, the propellant tank pressure =  $3.75 \text{ MPa}$ . A minimum pressure drop of 1.0MPa is to exist at the pressure regulator. Therefore, the minimum pressure upstream of the pressure regulator =  $4.75 \text{ MPa}$ .

#### Propellant Tank Volume

Thrusting time is to be in excess of 10s. Assuming an ullage volume of 5 percent of propellant volume and 5 percent of propellant volume for tube-passages and protuberances, with a standard one liter tank available in the market, the propellant volume that can be stored in the tank,

$$V_p = \frac{10^{-3}}{1.1} = 9.091 \times 10^{-4} \text{ m}^3 \quad (14)$$

say 0.9 liter

Volume flow-rate of propellant for the engine of 100N thrust,

$$\dot{V}_p = \frac{0.09013}{1400} = 6.4379 \times 10^{-5} \text{ m}^3/\text{s} \quad (15)$$

Therefore the maximum-possible thrusting time,

$$t_{\text{max}} = \frac{9.091 \times 10^{-4}}{6.4379 \times 10^{-5}} = 14.12 \text{ s} \quad (16)$$

As it is not being envisaged to fix any anti-vortex unit at the outlet within the propellant tank, arbitrarily a time of 12s is fixed as the maximum rated thrusting time. Therefore with the initial propellant volume of 0.9 liter, maximum thrusting time is around 12 s. The assembly drawing of engine that has been fabricated is shown in Fig. 1. The specifications of the engine are given in Table 2.

#### Hydrogen Peroxide Distillation Unit

Possibly the main impediment in starting the  $\text{H}_2\text{O}_2$  based rocket research is the difficulty in getting the rocket grade  $\text{H}_2\text{O}_2$ , say 90 percent or more of concentration. To solve this problem, a distillation unit has been realized and this is shown in Fig. 2.

In the 20 liter flask, Fig. 2, low concentration  $\text{H}_2\text{O}_2$  solution is stored. The distillation unit is evacuated to a pressure of about 100mm of mercury. The 20 liter flask is heated to a temperature around  $70^\circ\text{C}$ . The  $\text{H}_2\text{O}_2$  solution in the 20 liter flask starts boiling and the water contained in it evaporates to get condensed in the 10 liter flask. Thus the concentration of the sample in the 20 liter flask keeps increasing with time. Cold water is circulated in the condenser for the easy condensation of the water vapor. At any time, the concentration of the  $\text{H}_2\text{O}_2$  in the 20 liter flask can be found from the known initial concentration of  $\text{H}_2\text{O}_2$  solution and its initial volume,

and the volume of the water condensed in the 10 liter flask. Once the required concentration is reached in the 20 liter flask, the heating is stopped. After the unit gets cooled to ambient temperature, the vacuum is released. The concentrated  $H_2O_2$ -solution from the 20 liter flask is collected. The concentration of  $H_2O_2$  in the solution is evaluated accurately by weighing the known volume of the concentrated  $H_2O_2$ . If the concentration is found at the desired level, the concentrated  $H_2O_2$  is stored for the use in the rocket. The industrial grade  $H_2O_2$  of 50% concentration and the laboratory reagent grade, a variety purer than the former, of 30% concentration are freely available. For the present studies, the laboratory reagent grade is concentrated to 90% level.

### Test Facility

The sketch of the realized facility of the  $H_2O_2$  engine is shown in Fig. 3. Sufficient safety features have been incorporated by introducing burst diaphragm and relief valve in the test facility. All the control valves are remotely operated. As the pressure regulator of low flow capacity required for the 100N engine was prohibitively expensive, a pressure regulator of high flow capacity ( $c_v = 0.06$ ) had to be selected and this was made suitable for the 100N engine by adding a bypass orifice.<sup>17)</sup> Pressure transducers are fitted at five stations: pressurization tank, propellant tank, upstream of the injector, chamber pressure upstream of the catalyst bed, and downstream of the catalyst bed.

Propellant is filled into the 1000cc tank through quick connectors. Pressure regulator is set to the required propellant tank pressure. Recording and display of the pressure transducer-readings are initiated. Nitrogen supply is opened and it enters the gas pressurization tank of 1000cc volume after passing through 40 and 7 micron filters. Once the propellant tank pressure is stabilized, shut-off valve is opened to initiate the engine operation. The engine is fired until the propellant is consumed (~12s for 900cc of propellant). Once the propellant is consumed nitrogen-purging automatically follows to cool the engine.

In order to gain experience in the operation of the facility and also to prove the system, the facility has been tested extensively under simulated condition using water or nitrogen. While using nitrogen, the injector orifice and nozzle throat diameters were altered to simulate the engine operation. A typical recording of the simulated test using nitrogen is given in Fig. 4.

### Hot Test

20-mesh pure-silver screens were used for the catalyst bed. The silver screens were initially pickled with 50% nitric acid and subsequently activated with 2% solution of samarium nitrate. The total catalyst-bed

length of 55mm was stacked with 20 mesh silver screens interposed with three perforated separator discs of stainless steel (each of 4mm thick). The total catalyst bed was compacted at 15 MPa.

The initial attempts to fire the engine was not successful. A failed-test result is shown in Fig. 5. The test consisted of injecting the concentrated  $H_2O_2$  for two intervals with a gap of about two seconds: first for a short duration of about 1 s, (from ~1.8<sup>th</sup> s to ~2.8<sup>th</sup> s, Fig. 5) and the second for a long duration of more than 6 s (from ~4.8<sup>th</sup> s onwards, Fig. 5). Only pulsed decompositions (at ~3.4 s and ~4.9s) could be obtained.

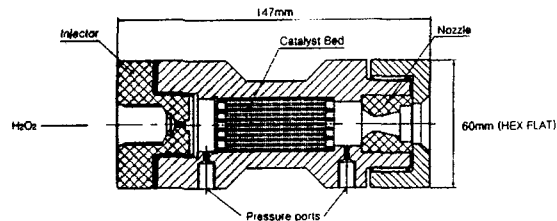

Fig. 1 Hydrogen peroxide engine of 100N thrust.

Table 2 Specifications of the  $H_2O_2$  engine and its facility

Engine thrust	= 100 N
Estimated specific impulse	= 1110 N-s/kg
Regulated $H_2O_2$ tank pressure	= 3.75 MPa
Injector pressure drop	= 0.70 MPa
Injector orifice diameter	= 1.8 mm
Nozzle entry stagnation pressure	= 2.0 MPa
Propellant flow rate	= 0.090 kg/s
Catalyst bed-length	= 55mm
Approximate thrusting time	= 12 s
Nozzle throat diameter	= 7 mm
Nozzle exit diameter	= 12 mm

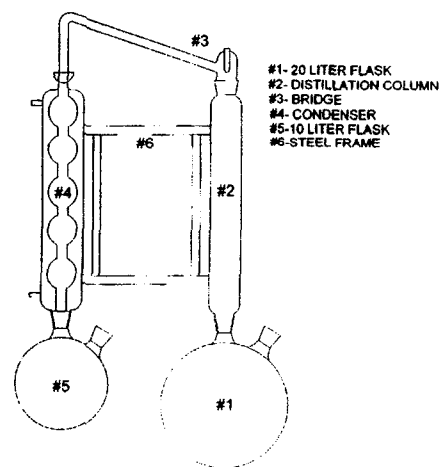

Fig. 2 Hydrogen peroxide distillation unit.

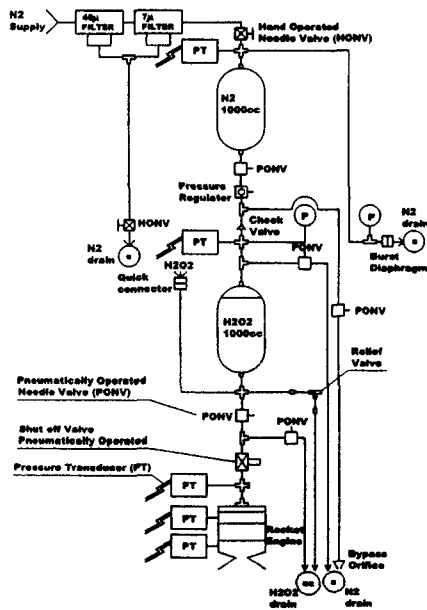

Fig. 3 Hydrogen peroxide rocket engine facility.

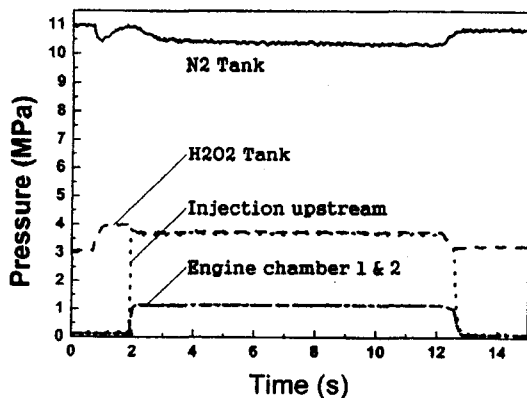

Fig. 4 Engine pressure-recordings of a simulated test using nitrogen.

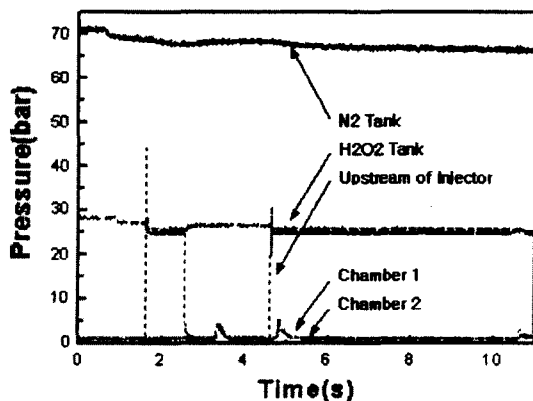

Fig. 5 Pressure-time traces of a hot test that failed.

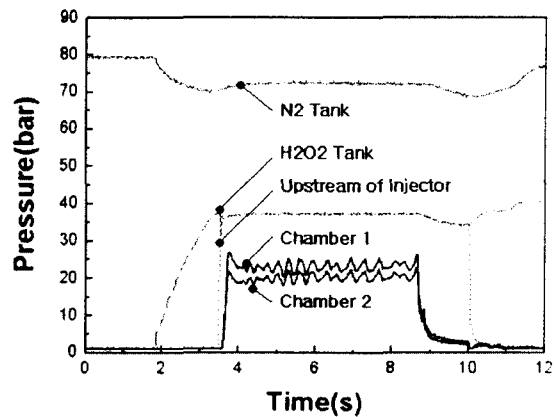

Fig. 6 Typical result of a successful hot test.

The possible reasons for the  $H_2O_2$  not getting decomposed at the catalyst bed could be three. The first could be the low environmental temperature. At the time of the test the atmospheric temperature was around  $5^\circ C$ . Willis<sup>13</sup> reported the most pronounced effect of engine case temperature on starting-time delays and most of his tests were conducted at the case temperature of  $200^\circ C$ . Love and Stillwell<sup>16</sup> maintained the propellant tank at a temperature around  $30^\circ C$ . The second possibility is the insufficient surface contact of the catalyst material with the  $H_2O_2$ . In the initial tests 20 mesh silver screens were used. Runckel et al.<sup>15</sup> found 40 mesh silver screens to be better than 20 mesh silver screens. The third reason could be the contaminations in the concentrated  $H_2O_2$ . Whitehead<sup>18</sup> explains the importance of reducing the contaminations in preparing a propellant grade concentrated  $H_2O_2$ .

As the next developmental activity, the propellant tank was jacketed with heater elements and maintained at  $35^\circ C$ . The engine case was also jacketed with heater elements and maintained at a temperature of  $60^\circ C$ . In order to increase the surface area of the catalyst screens, the catalyst pack was compacted at 35MPa. The hot tests with these modifications were successful and a typical test result is shown in Fig. 6. Further tests to understand the effects of environmental temperature (propellant temperature and engine case temperature) and of catalyst contact area are in progress.

### Concluding Remarks

Because of the growing interest in using propellants of low toxicity and enhanced versatility, there has been a renewed interest in the use of hydrogen peroxide ( $H_2O_2$ ) as an oxidizer in bipropellant liquid rocket engines as well as in hybrid rocket engines. A brief review of the ongoing developmental programs reveals that the application of  $H_2O_2$  in rocket propulsion is quite varied: reusable launch vehicles, upper stage propulsion, emerging defense applications, tactical missiles, micro-satellite propulsion, orbital maneuvering systems, crew escape

systems, and all upper stage and on-orbit applications requiring lower life-cycle costs and improved safety.

Considering the importance of this "green" and versatile H<sub>2</sub>O<sub>2</sub>, it has been planned at Kyungpook National University to develop a test facility for research in the areas of H<sub>2</sub>O<sub>2</sub> propulsion.

The detailed design of a laboratory scale facility of the H<sub>2</sub>O<sub>2</sub> mono-propellant engine (100-N thrust) has been presented.

Initial hot tests revealed the needs to have a controlled high temperature environment for engine and propellant. A modification incorporating enhanced temperature for the propellant and engine case and increased catalyst contact area by compacting the catalyst pack at a higher pressure yielded successful firing of the engine.

### References

- 1) Tsujikado, N., Koshimae, M., Ishikawa, R., Kitahara, K., Ishihara, A., Sakai, Y., and Konishi, K. : An Application of Commercial Grade Hydrogen Peroxide for Hybrid/Liquid Rocket Engine, 2002, AIAA Paper 2002-3573.
- 2) Wernimont, E., and Ventura, M.: Catalyst Bed Testing for Development of a 98% Hydrogen Peroxide Procurement Specification, 2002, AIAA Paper 2002-3852.
- 3) Beutien, T. R., Heister, S. D., Rusek, J. J., and Meyer, S.: Cordierite-Based Catalytic Beds for 98% Hydrogen Peroxide, 2002, AIAA Paper 2002-3853.
- 4) Helms, W. J., Mok, J. S., Sisco, J. C., Anderson, W. E.: Decomposition and Vaporization Studies of Hydrogen Peroxide, 2002, AIAA Paper 2002-4028.
- 5) Abel, T.: Hybrid Rockets, *Aerospace America*, 37 (12), 1999, p. 75.
- 6) Abel, T.: Hybrid Rockets, *Aerospace America*, 38 (12), 2000, p. 41.
- 7) Rohrbaugh, E. M.: Hybrid Rockets, *Aerospace America*, 39 (12), 2001, p. 61.
- 8) Frolik, S.: Hybrid Rockets, *Aerospace America*, 40 (12), 2002, p. 61.
- 9) Maisonneuve, Y., Godon, J. C., LeCourt, R., and Lengelle, G.: Hybrid Propulsion for Small Satellites: Design Logic and Tests, 5<sup>th</sup> International Symposium on Special Topics in Chemical Propulsion (5-ISICP): Combustion of Energetic Materials, 2000; K. K. Kuo and Luigi T. DeLuca (Eds.): *Combustion of Energetic Materials*, Begel House Inc., New York, 2002, pp. 90-100.
- 10) Fisher, S. C.: Liquid Propulsion, *Aerospace America*, 40 (12), 2002, pp. 64-65.
- 11) Gordon, S., and McBride, B. J.: Computer Program for Calculation of Complex Chemical Equilibrium Compositions, Rocket Performance, Incident and Reflected Shocks, and Chapman-Jouguet Detonations, NASA SP-273, 1971.
- 12) Wernimont, E., and Mullens, P.: Capabilities of Hydrogen Peroxide Catalyst Beds, 2000, AIAA Paper 00-3555.
- 13) Willis, C. M.: The Effect of Catalyst-Bed Arrangement on Thrust Buildup and Decay Time for a 90% Hydrogen Peroxide Control Rocket, NASA TND - 516, 1960.
- 14) Wanheim, J. P., Ross, P. S., and DeWitt, R. L.: Effect of Propellant and Catalyst Bed Temperatures on Thrust Buildup in Several Hydrogen Peroxide Reaction Control Rockets, NASA TND-480, 1960.
- 15) Runckel, J. F., Willis, C. M., and Salters, Jr., L. B.: Investigation of Catalyst Beds for 98% Concentration Hydrogen Peroxide, NASA TND-1808, 1963.
- 16) Love, J. E., and Stillwell, W. H.: The Hydrogen Peroxide Rocket Reaction-Control System, NASA TND-185, 1959.
- 17) Ahn Sang-Hee, Choi Tae-Hon, Krishnan, S., and Lee Choong-Won.: A Laboratory-Scale Hydrogen-Peroxide Rocket Engine Facility, 39<sup>th</sup> AIAA/ASME/SAE/ASEE Joint Propulsion Conference and Exhibit, 2003, AIAA 2003-4647.
- 18) Whitehead, J. C.: Hydrogen Peroxide Propulsion for Smaller Satellites, 12<sup>th</sup> Annual AIAA/USU Conference on Small Satellites, 1998, Paper 98-VIII-1.