

Control and Development of LonWorks Intelligent Control Module for Water Treatment Facility Based Networked control System

Won-Pyo Hong*, Dong-Hwa Kim**

* Department of Building Services Engineering, Hanbat National University, Daejeon, Korea
(Tel : +82-42-821-1179; E-mail: wphong@hanbat.ac.kr)

**Department of Control Instrumentation Engineering, Hanbat National University, Daejeon, Japan
(Tel : +81-42-821-1170; E-mail: kimhd@hanbat.ac.kr)

Abstract: With distribution industrial control system, the use of low cost to achieve a highly reliable and safe system in real time distributed embedded application is proposed. This developed intelligent node is based on two microcontrollers, one for the execution of the application code, also as master controller for ensuring the real time control & the logic operation with PLD and other for communication task and the easy control execution, i.e., I/O digital input, digital output and interrupting. This paper also presents where the case NCS (Networked control system) with LonTalk protocol is applied for the filtration process control system of a small water treatment plant.

Keywords: Distributed Control System, Fieldbus, LonWorks, Water treatment control, Neuron chip, DSP(Digital signal Processing) chip, Networked control system

1. INTRODUCTION

In recent year, the case to install small water facility to every local area has increased. A key issue in the successful implementation of the control system for the water treatment plants is the choice of the control architecture. Within the framework of the distributed control system (DCS), this paper presents a new development of the intelligent control module and its application to the filter system water of the treatment facility based on LonWorks network control system. This control system so called NCS (Networked Control System) with standard network, LonTalk protocol of ANSI/EIA 709.1 has suitable functionality to operate these distributed water treatment facility effectively. The important characteristics features with standard network function, regulatory control function and information dispatch function give the improvement of its robustness of NCS. This describes the case where NCS is applied for the filter system in water treatment facility of Hwungsung area.

2. BACKGROUND OF WATER TREATMENT CONTROL SYSTEMS

Traditional process control systems including the water treatment control system have used centralized control and data management. The DDC (Direct Digital Control) and PLC (programmable Logic Controller) are the key elements of the control in such systems. Enterprise level functions are implemented with supervisory computer connected to the PLC via a network. More recently, traditional systems are being replaced by DCS where many of the functions formerly residing in the central computers have been moved to computers closer to the process being controlled. This distribution of function provides increased capacity, relieves computational and communication bottlenecks, and generally provides more flexibility in the system design, modification, and expansion [1]. In both the traditional process control system and in the DCS, their computer directs the actions of instruments, sensors and actuators; polls for any results; and manages the resulting data. The essential determination of the system's behavior resides in the PLC or DCS controller. Communication is one-to-one between the controller and each instrument, sensor, or actuator.

Today, various fieldbus technologies and the ability to in expensively place significant computation capability in the

transducers permits systems with even greater distribution of function than in the current DCS technology[2]. In such a system, the nodes, this is, the instruments, actuators, and sensors, determine the over system behavior, rather than depending on a PLC or DCS computer for control. In addition, nodes communicate directly with each other or with groups of other nodes with any restriction to one-to-one communication links. Fieldbus provides a digital, two-way, multidrop communication link among intelligent field device and automation system. Emergence of fieldbus accelerates digitalization in field devices and brings high functionality to the field. This change of instrumentation systems then invites openness in the process control systems. A new capability for measurement, control instrumentation and process diagnostics is now available. Customers, however, do not want drastic change on their existing instrumentation system, even if they fell welcome to this structural change on the control systems. At the introductory phase of the fieldbus, the majority of customers prefer step by step addition or part by part replacement for the existing system based on DCS. It is easily comprehended that the extinction or complete replacement of DCS and device would be an unreasonable task both in money cost and human efforts [3]. The most feasible subject to be considered seems to be how to harmonize fieldbus with conventional DCS to work at a full potential. Such consideration to control systems enables flexible system configuration for wide range of application. The major DCS system to be used today were designed and installed before the work to standardize fieldbus was finalized. Although fieldbus has many benefits and impacts on DCS, further distribution of control functions to the field does not mean immediately extinction of DCS. DCS will continue to perform its mission, particularly in application where higher level control or highly reliable control is required. Introducing fieldbus while utilizing abundant monitoring, operating and advanced control function of DCS at the same time, such instrumentation systems will gain the maximum advantage.

So, the principle of integrating fieldbus into DCS is also the main technical challenge:

- Taking advantage of fieldbus as full as possible but
- Bringing minimum impact or spoiling to the existing systems

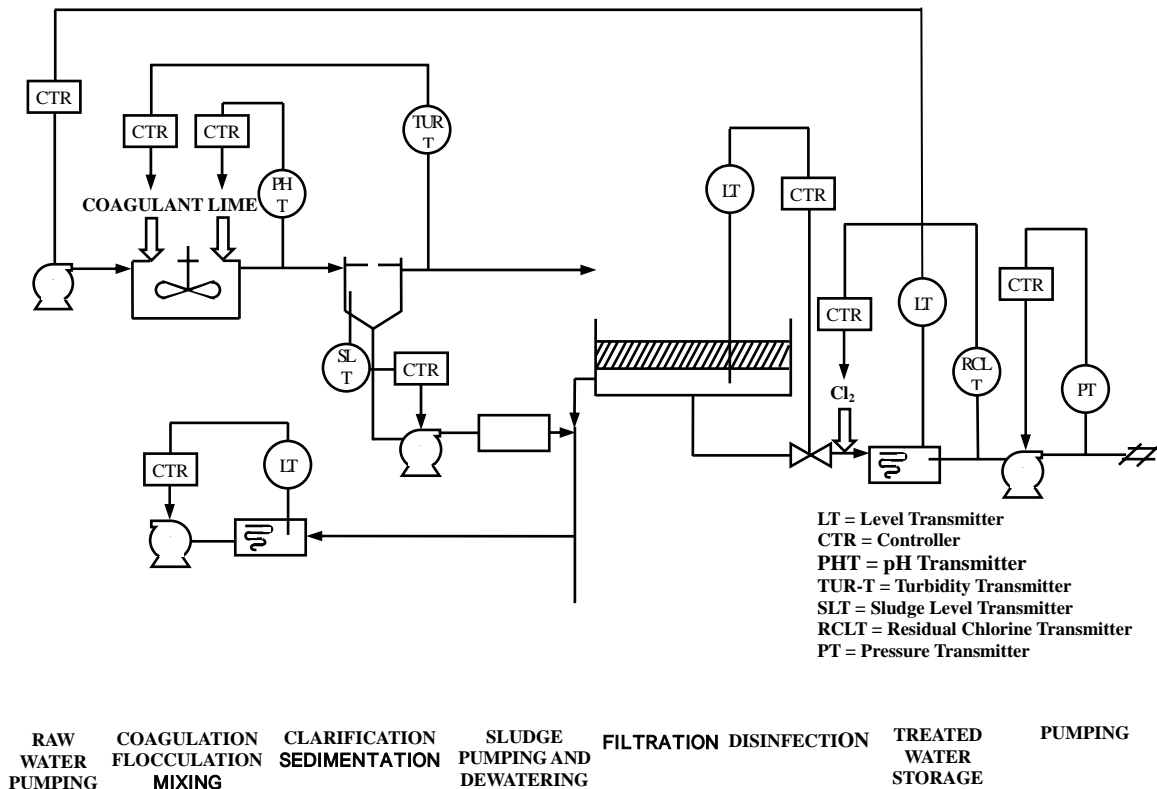

Fig.1. Schematic of a controlled treatment

3. WATER TREATMENT PLANT CONTROL PROCESS AND AUTOMATION

3.1 Overview of water treatment plant control process

In order to put water treatment plant process control and automation in perspective, it is necessary to understand how the treatment plant relates to the other components of water system processes. Figure 1 illustrates schematically how treatment relates to other system processes [4].

This generic treatment plant is composed of eight separate processes. Realizing that this represents only one possible treatment scheme, it can serve as the common plant form from which to discuss treatment plant process control. The individual processes, or modules, to be controlled include the following:

- Raw water pumping. Pumping is used throughout a treatment plant. The consumption/demand clear well level controls the pumping
- Chemical addition for coagulation. The addition of coagulant aids or softening aids is very prevalent in water treatment. The chemical feed is controlled by flow and raw water quality and is trimmed by the quality of the water after treatment.
- Coagulation/flocculation/mixing. The combination of coagulation/flocculation/mixing is usually found whenever conventional coagulant aids are used. The process is usually controlled based on the raw water quality and the feed rate of the chemicals.
- Clarification/ sedimentation. Clarification/sedimentation comes in many different configurations. This process is most

effective if applied after hydraulic control. Splitting flow among multiple units is often very important to process efficiency.

- Filtration and filter washing. The filtration and filter washing process must treat what is delivered to it. The flow rate to the filters determines the number of filters on line, and the filter level often determines the future flow rate. There are many variations of this control scheme. Sequencing of filter washing is a key process control application for this unit process.

- Disinfection. Disinfection has many variations and options. Typically, the chemical used for disinfection is controlled based on the flow of treated water being delivered to the clear well. The feed rate is then trimmed by the residual chemical after a period of contact. If a residual measure is not available, open loop control or per-shift adjustments, based on laboratory samples, are typically performed.

- Treated water storage and distribution pumping. The treated water storage reservoir level is a key variable in a water treatment process. The rate of demand or consumption is what affects the clear well level. This level controls the rate of raw water pumping. The distribution pumping unit operation is most often treated as part of the distribution system and is manually controlled by the supervisory control and data acquisition (SCADA) system based on demand.

- Sludge pumping and dewatering. Sludge can be pumped and dewatered using many options and variations. Generally, sludge is pumped on a continuous basis, with the rate varying in order to control the sludge solids concentration. The dewatering operation is normally controlled based on the solids loading to the unit process.

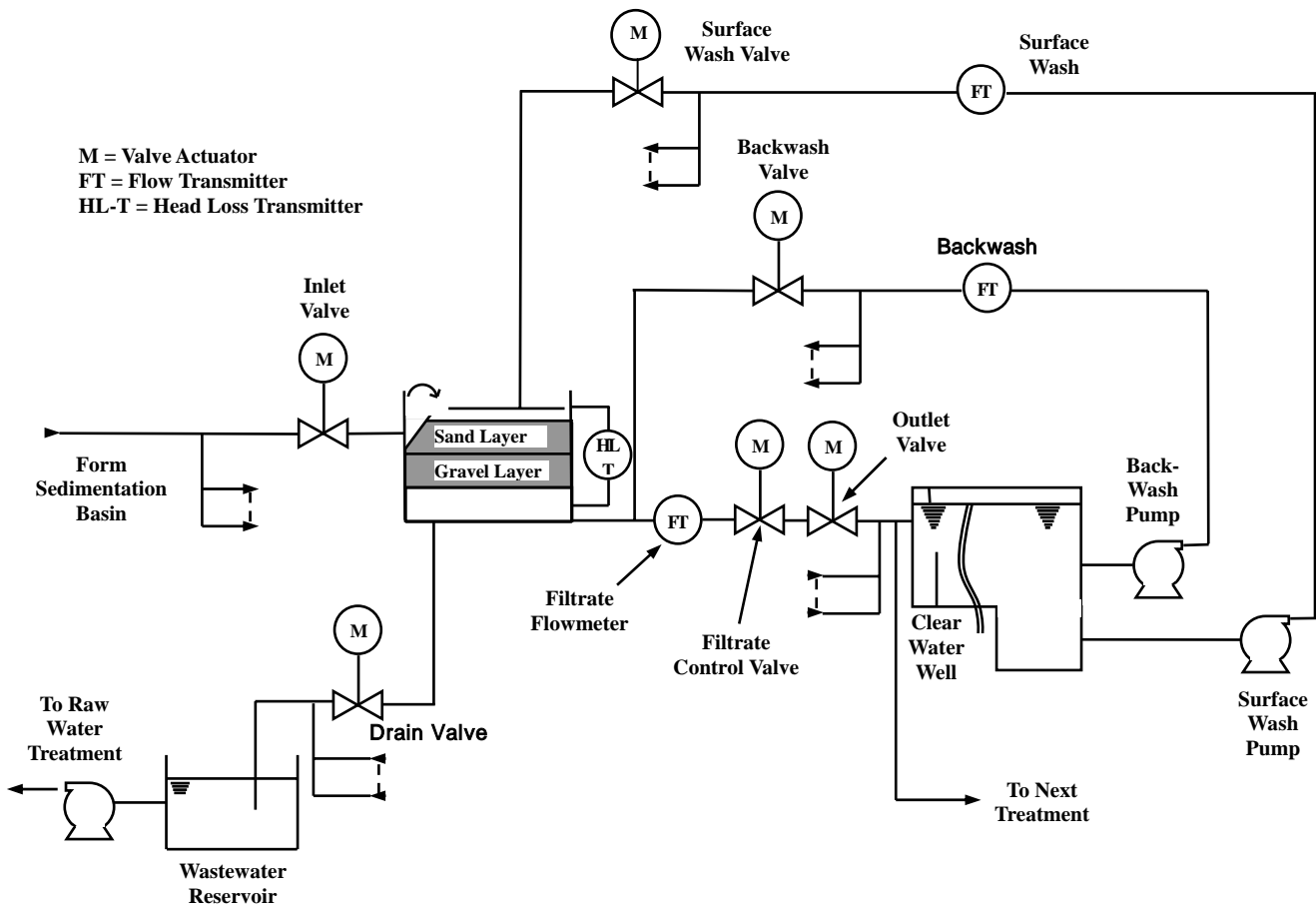

Fig. 2 Schematic of filter basin automation

3.2 Filter Basin Automation

The purpose of filtration is to trap suspended particles in the water, retain them temporarily, and detach them during the wash cycle. Therefore, facilities always include a filtering device and an associated washing device. The automation for the entire filtration process is divided into four parts: verification of proper operation during filtering, detection of the need for washing, start-up, and monitoring of the washing cycle. Filter techniques include filtering using a supporting media, filtering through a granular bed, and membrane filtering. Other filter methods are less commonly used. In this study, the rapid granular bed filtration is focused on. A constant rate filtration process is described here as a typical example of filtration flow quantity control. The set point for total filter volume is determined by the treatment plant's unit control system. This number is sent to the controller responsible for operating these basins. The total filtered volume set point is divided by the value indicated by the number of operating filtration basins. The setup is designed to prevent an abrupt change in set point at each filter's flow control system. A time basis is provided, so the transition from the old set point to the new is gradual. The instrumentation system is configured so that the flow to the other operating basin enters the washing mode. Gradual response to the set point prevents detaching of floc held loosely on the surface of filtering particles in the bed. Otherwise, floc particles would fall if the flow velocity changed abruptly. This function is also used in the slow-start mode to resume filtration after washing.

A filter configuration is shown in Fig. 2. This is a description of filter management during the filtering phase. But filter washing management is carried out at the same time. First, it is necessary to determine when each filter needs washing. A washing request is triggered when a threshold on one or more parameters is reached; parameters vary according to water quality and the size of facilities. Common criteria are volume filtered and time lapsed since last wash, filter water turbidity, and filter clogging. Requests are recorded in chronological order, with the goal being to wash filters automatically during non-peak periods when energy rates are lowest. In order to optimize the time between washes, the corresponding pumps are managed by the washing program. Digital programmable instrumentation is best suitable for control systems of this type. Typically, the filter flow set point is controlled by the filter level or the desired plant flow modified by the number of filters on line.

4. DEVELOPMENT AND DESIGN OF INTELLIGENT MODULE WITH HIGHER PERFORMANCE

The section of microprocessors is governed by various factors, being mainly dependent on the nature of the applications to be addressed. Among field-bus systems and control networks on the market, LonWorks offers perhaps the most powerful features in term of architecture, communication flexibility and network management. LonWorks is chosen for the research study

largely to take advantage of its architectural features, flexibility and its comprehensive range of development tools. The case study is based on the use of Neuron chips which are sophisticated VLSI devices that make it possible to implement low-cost local operating networks applications.

4.1 Intelligent LonWorks node

LonWorks from Echelon is a complete system that incorporates a communication standard with ANSI/EIA 709.1. It also includes management and control. The neuron chip contains three eight-bit processors. The block diagram of the master controller developed for a water treatment process control is shown in Fig.3. The application processor is executing user code written in a variant of Neuron C language with powerful input/output functions. A network processor handles addressing, routing, authentication of packets and the presentation of data to the application processor. The MAC processor is responsible for encoding I/O, importing measurement, calculating, calibration and transmission of packets of data to the network. Most of intelligent functions are implemented by embedded neuron networks stored in EEPROM. These two processors comply with six layers of the ISO reference model. This allows the transparent use of the network to pass information between the different programs in the application processors.

• Simplified interface module design

There are 34 different I/O objects available within a Neuron chip. Various I/O objects may be used simultaneously if desired. With this provision, the interface circuit between the controller and the physical devices can be greatly simplified, reducing the size and the costs of the devices and offering enhanced reliability.

• Three dedicated CPUs and built-in firmware

Three CPUs are employed on a Neuron chip, with two of them handling the layers one to six which conform to the seven-layer network protocol stack, i.e. driving the communications subsystem hardware, executing the collision avoidance algorithm, network variable processing, addressing, transaction processing, authentication, background diagnostics, software timer, network management, and routing functions. This enables the development effort to focus on application programming, instead of spreading a considerable amount of time in dealing with the communications protocol and communication interface circuit. The firmware embedded in the Neuron chip contains communication protocol, an operating system and data I/O applications library []. This simplifies applications programming as the data I/O communication and I/O devices are automatically handled through a library call.

• Multi communication medium and communication data rates

Neuron chip based on LonWorks supports multi-communication medium, such as; twist pair cable, coaxial cable, power line, radio frequency, infrared and optical fiber. It also supports a wide range communications data rates from 4.9-1250Kbit/s. The versatility in communication medium and data rates in fact a unique feature among fieldbus systems and control networks currently available on the market.

• High level programming language

Neuron C is a programming language designed for Neuron chips and is based on the ANSI C language. It includes extension to ANSI C that directly supports the Neuron chip firmware, which make it a power tool for the development of LonWorks application. The use of high level programming languages is a desirable feature now offered by controller developer and suppliers. This can be seen as a move towards code portability and self-documentation. The dependency of software code on a particular processor or platform is seen as a stumbling block for developers from quickly adapting to the use of the latest and most appropriate processing platforms.

• Exploitation of network variables

Using the Neuron chip as the controller of the intelligent devices you can use Standard Network Variable Types (SNVTs). SNVTs provide a data-oriented application protocol. Application data items such as speed, length, states, text strings, and other data items are exchanged between devices in standard engineering and other defined units. Commands are encapsulated within the application programs of the receiver devices rather than being sent over the network. In this way, the same engineering value can be sent to multiple devices even though each device has a different application program for the data item. SNVTs facilitates interoperability by providing a well-defined interface for communication between nodes made by different manufactures, A node may be installed in a network and logically connected to other nodes via network variables as long as the data types match. Comparing network variables with commands and using network variables rather than commands will result in smaller application programs, implicit buffer allocation/freeing and optimizing communication services at installation rather than during application development. A developer does not then have to concern himself with how and where the devices will be connected and the communication with other devices is established.

• ID of the devices

A unique 48-bit ID is assigned with each Neuron chip when manufactured. The 48 bit ID may be read and used by application programs as a unique product serial number. It can also be used as a network address during installation and configuration.

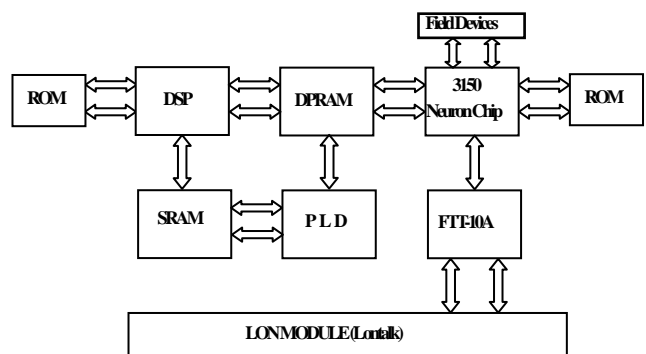

Fig. 3 Block diagram of master controller based on LonTalk protocol

4.2 Example implementation of intelligent master controller.

In this section, the development of a control system for only filtration system of the small water treatment plant is described to illustrate intelligent device components. Fig. 4 shows the block diagram of intelligent control module which is developed for being used in the filtration control systems, whereby five elements are involved, namely a TMP3150 Neuron chip, TMS320C32 DSP chip, Transceiver (FTT-10A), ROM, SRAM for DSP, PLD (EPM7084) and Dual Port Static RAM. The two CPUs is connected by the dual port static RAM. The objective of the architecture is to obtain improvements in reliability, safety at low cost and the achievement of high performance in the networked control system. This intelligent control module fabricated in one small board is implemented by us for replacing PLC system for the first time.



Fig. 4 Master Controller based on LonWorks network

Table 1 Specification of master controller hardware

Host CPU	CPU Type Clock ROM Memory RAM Memory	TMS320C32PCMA50 50MHz 512k EEPROM 4Mbit SRAM(Battery Back up)
Slave CPU	CPU Type Clock ROM Memory RAM Memory	TMPN3150 10MHz 512K EEPROM None
Protocol	LonTalk	
Transceiver	FTT-10	
Power	16- 36 VDS/AC	
Microprocessor interface program	MIP/DPS Echelon	

Table 2 Specification of memory

Maximum number of Network variable	2048
Maximum number of Alias	500
Capacity of application program	150KByte
Virtual Digital	500
Virtual Analog	500
Timer(second)	100
Timer(minute)	100
Timer(hour)	100
Counter	100

From a practical point of view, the main components are:

- 32-bit DSP microcontroller for the fast execution of the control algorithms and complex logic operation. The field data for the fast processing are transmitted from the LonWorks control modules to connect I/O of filtration systems. After the control and command data is processed and executed, they are sent the pertinent data and information to LonWorks control modules through Dual-port RAM. This host controller has the 512Kbit EEPROM and 4Mbit SRAM.

- 8-bit microcontroller to be named Neuron Chip , which is working at 10MHz. devoted to communications and control modules with LonTalk protocol for executing digital output/digital input signal of the filtration systems. This slave controller of the TMPN3150 CPU type has the 512K EEPROM.

- Dual-port static RAM to pass information between both microcontrollers and to store the node state. High-speed dual-ported RAM interface sends and receives hundreds of packets per second with minimum host overhead.

- Communication networks based the LonTalk protocol.
- A serial RS-232 is included for 32-bit DSP microcontroller in order to make local channels possible in each node, and also to allow software updates via RS-232 for microcontroller. We get the final data processed and operated from DSP chip through RS-232 port. Further, this can use to the gateway to translate LonTalk protocol to RS-232.

- The Transceiver
A transceiver provides the mechanical and electrical interface between the Neuron chip of the device and the communication medium. Multi-medium transceivers enable the actuator and sensors to operate in different environment.

- Microprocessor Interface Program (MIP)
The Microprocessor Interface Program is firmware for the Neuron Chip that transforms the Neuron Chip into a communications coprocessor for an attached DSP. The MIP enables the attached host to implant LonWorks applications and to communicate with other devices using the LonWorks protocol. Applications on the host can send and receive network variable updates and application messages, as well as poll network variables. The MIP/DPS id typically used with high-performance host such as 23-bit microprocessors, but may be used with any host. The Neuron Chip running the MIP/DPS communicates with the DSP using a dual ported RAM with hardware semaphores. The network interface with the MIP handles layers 1 through 5 of the LonWorks protocol. This significantly reduces overhead in the host since the host processor does not have to deal with lower layer network services such as media access control, collision avoidance, acknowledgements, retries, duplicate message detection, message validation, authentication, and priority processing. The DSP id left to run the application program and handle the layer 6 and 7 protocol services: network variable processing, and explicit message processing. Using these services, the DSP can easily send and receive both network variable updates and application message.

4. 3 Procedure of programming

Fig. 3 shows PLC Logic composed by LonMaker for Window which is the tool of LonWorks network design. PLC Logic editor does not provide the practical IO, but only PLC Logic composition. The unique binding is to connect IO and

controller shown in Fig. 3. Users can append 2096 network variables of PLC logic and remove at their disposal.

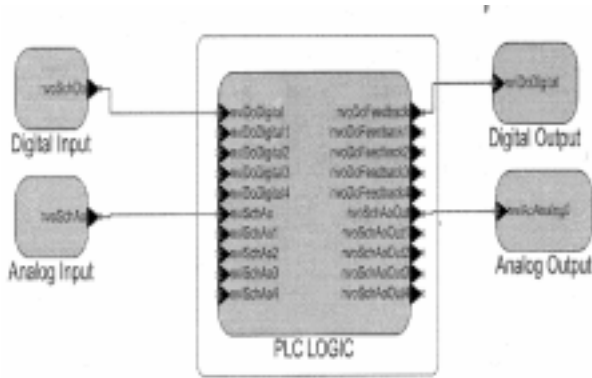

Fig. 5 Binding of PLC Logic by LonMaker for Windows

4.4 Sequence of logic procedure

All logic must be started in the main page. If you operate another page, It is proceeded in the main page after using call function object. Sequential logic can be easily drawn up. Fig. 6 shows an example of the sequence of logic procedure. The executing sequence is setting nvoSchAoOut firstly and next setting is as followings: nvoSchAoOut1, nvoSchAoOut2, digital data 3, STimer 1 according to conditional state, and finally, nvoSchAoOut3.

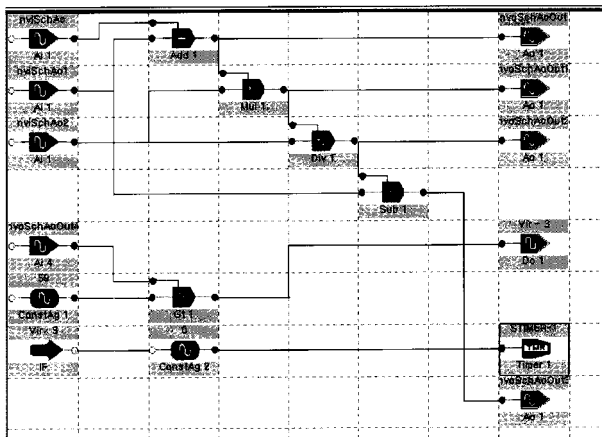

Fig. 6 Sequence of logic procedures

5. CONCLUSIONS AND DISCUSSIONS

In this paper, a new distributed control system in the water treatment process system for embedded real-time applications is presented. LonWorks Intelligent control module (LICM) is developed first to apply to the water plants scattered around the area. It is confirmed already that this master controller with LonTalk protocol had an experience on the installation to a wastewater treatment plant of Rohm Korea located at Daejeon city. Until now, its result shows the effectiveness of internal mechanism and the high performance of execution control by a new master controller. Now, LICM is installed to control the small water treatment facility of Hwungsung area.

. A new development of intelligent control module and its novel application to the filter system of water treatment

facility based on the LonWorks network control system expect to play an important role on application of LICM to water treatment plant. The important characteristic features with standard network function, regulatory control function and information dispatch function give the improvement of its robustness, saving of wiring cost and easiness of maintenance of NCS.

LonWorks use for intelligent control module implementation, also is verified by the following remarkable advantages: firstly, the intelligent nodes which has high processing capability by DSP to connected to LonWorks network can become generic building blocks that are used in multi applications to accomplish different tasks, secondly, the separation of the various design tasks enables system of unprecedented flexibility and interoperability.

This describes the case where NCS is applied for the filter system in water treatment facility of Hwungsung area.

ACKNOWLEDGMENTS

This work is supported by the Electrical Engineering & Science Research Institute under 2001 year project and Hanbat National University under 2002 year project.

REFERENCES

- [1] W.P. Hong, "A novel design of the intelligent fire alarm signaling system for the integration of BAS by developing intelligent control modules with LonTalk protocol of ANSI/EIA 709.1," *Journal of the KIIEE*, Vol. 17, No. 4, pp. 64-73, 2003.
- [2] F.L.Lian, et.al, "Network design consideration for Distributed control system," *IEEE Trans. on Control System Technology*, Vol. 10, No. 2, pp. 297-307, 2002.
- [3] L. Lingqi, et.al, "Integration of Fieldbus into DCS," *SICE'99*, pp.1043-1046, 1999.
- [4] K..Makino, et.al, "Treatment plant process control," *British Library Document LS23 7BQ*, pp.183-221.
- [5] J.C Eidson, et.al, "A research prototype of a control system based on smart transducers," *ISA Transactions* 34 pp. 17- 24. 1996.
- [6] J. C. Campelo, et.al, "A real-time distributed industrial control system for embedded applications," *Control Engineering Practice*, Vol. 9, pp. 439-447, 2001.
- [7] M.Furutsuki, et.al, "Network Based control system suitable for distributed water treatment facility," *SICE*, pp.3122-3126, 2002.
- [8] W.P. Hong, et al., " A Novel Design of the Distributed Fire Alarm Control System by Developing Intelligent Control Modules with LonTalk Protocol", *ICCAS 2001*, Oct. 17-21, Cheju National Univ., Jeju Island, Korea, 2001.
- [9] Echelon Co., "Neuron C Reference Guide," 1999.
- [10] Echelon Co., "LonWorks MIP/DPS Developer's Kit Model 23210," [http:// www.echelon.com](http://www.echelon.com).