

## Developing Intelligent Control Modules with LonTalk Protocol for Intelligent Building System & Home Automation

Won-Pyo Hong, Dong-Hwa Kim\*, Sung-Hak Lee\*\*

Dept. of Building Service Eng., Hanbat National University, 16-1 Dukyoung-Dong Yusong-Gu Daejon City Seoul, Korea

\*Dept. of Instrumentation and Control Eng., Hanbat National University, 16-1 Dukyoung-Dong Yusong-Gu Daejon City Seoul, Korea

\*\*Dept. of Instrumentation and Control Eng., DaeDuk College, 48 Jang-Dong Yusong-Gu, Daejon City, Seoul, Korea

**Abstract:** There are many economic and operational reasons to integrate fire alarm signaling system with other building automation system. Integration of this requires open network with for the standard communication protocol and careful design practices. The important point for this is also the development of intelligent control modules for replacing the conventional zone adapter in fire system. Therefore, this paper proposes a new conceptual design of the open distributed fire alarm signaling system for the integration of BAS, a new intelligent control modules with LonTalk protocol and a new control modules for power line communication. Newly proposed additions to LonWorks network make it very well suited for integrating fire systems with other building automation sub-systems and another BAS with low cost. Additionally, it is very important that best design practices, test procedures and building codes need to be modernized to accommodate integrated building systems.

**Keywords:** Fire alarm signaling system, LonWorks, LonTalk, Building Automation System, Intelligent building System, Power Line communication

### 1. Introduction

The Internet & contents have dramatically accelerated the rate at which different forms of information are merging, thus allowing uninhibited mixing of information types for solving everyday problems. Its rapid advancements also have much influence on an intelligent building system (IBS), building automation and control systems and intelligent home automation(IHA)

The IBS can be defined as one that combines the best available concepts, designs, materials, systems and technologies to provide a responsive, effective and supportive intelligent environment for achieving the occupants objectives over the full life-span of the building [1,2]. To fully accomplish the intrinsic targets of the IBS, Intelligent building technology generally refers to the hardware & software integration of four systems: a Building Automation System (BAS), a Telecommunication System, a Office Automation System and a Computer aided Facility Management Systems. A sophisticated BAS is actually the heart of every intelligent building. State-of-the art building automation and control systems is characterized by open networks and intelligent distributed controllers that process complex algorithms

systems, lighting control systems, access control systems and fire detection systems. In spite of these advances, building owners have been frustrated by the inability to bid projects competitively and to integrate innovative suit the unique needs of their facility. The main obstacle has been incompatible proprietary communication protocols. The adoption of LonTalk[3] and BACnet[4] as the standard communication protocol for integrating building control products has changed the industry and opened the door to new innovation in building control technology and true integration of isolated building system, especially, the fire alarm signaling control system. Fire detection and the corresponding safety systems are crucial parts of an intelligent building. Intelligent distributed systems developed in the intelligent building offer opportunities to meet this task more effectively, efficiently and economically. IBS hold the potential for reducing false alarms, speeding building evacuation and assisting in fire fighting. With the developing of microelectronics and network communication technology, the fire alarm control system demands more adoption of these technologies. Because of the advanced network technology, the large scale and super large-scale fire alarm systems have been widely used. In order to insure the stability of the systems, the control units must have the characteristic of independence in case of failure of the internal network. Now integration is a tendency of the control systems within buildings. So a fire alarm system needs the open characteristic to fit the demand. This paper presents an open distributed fire detection system to completely integrate a BAS. The intelligent control modules (ICM) with ANSI/EIA 709.1 LonTalk protocol for replacing the conventional zone adapter in fire detection system has been developed and ICM with power line communication was developed for configuring cost effective network system. We also propose a new conceptual design of the open distributed fire alarm signaling system for the integration of BAS. The potential effects of integrated building service systems and barriers to development of fire detection and alarm system in intelligent buildings are discussed and a new intelligent control modules with LonTalk protocol. Newly proposed additions to LonWorks network make it very well suited for integrating fire systems with other building automation systems.

## 2. The state-of-the art and problem of integration issues

Today's fire detection and alarm systems have been partially integrated with other building systems. Once a fire occurs in a building, fire detection and alarm systems activate various fire safety systems, such as smoke control, and various pressurization and smoke exhaust system. They also activate elevator recall, the door release system, flashing exit signs and fire suppression systems [5]. Currently, however, the level of integration of all the disparate building system is still limited. Various building service systems involving HVAC, lighting, fire safety, and security monitoring in the building are not integrated together on the basis of an open network with the standard communication protocol. This is mainly due to fragmentation of the building and communication industries, a reluctance to change established practices as well as the lack of standardized, broadly-based communication protocol that allow different type of building service systems to communication with each other. All the components of the fire detection and alarm system reside on one side of the gateway and communicate limitedly using proprietary protocol. Various methods and concepts have been developed to enhance integration of building system and increase reliability of the integrated systems [6]. Efforts are also being made to develop communication protocols that enable different manufacturers to interoperate together and allow the building systems to communicate with each other over a network. These protocols include BACnet, LonWorks, CAN, EIB, InterBus, and DeviceNet and so on. LonWorks and BACnet has been used widely in the building automation fields.

BACnet prefers a hierarchical model in which the whole system is divided into a number of subsystems, each with a separate central processing unit [7]. BACnet is most suitable to the traditional processing and communication models used by current HVAC hardware. However, BACnet does not support dynamically structured network, nor does not it emphasize distributed processing. Efforts are being made to expand BACnet beyond the HVAC realm.

One of the open control networks is the LonWorks system developed by Echelon Cooperation. LonWorks technology allows all manner of control devices to communicate with one through a common communication protocol that is shared among all devices. Communication transceivers and transport mechanism are standardized, as are object model and programming/troubleshooting tools to enable the rapid design and implementation of interoperable, LonWorks-based devices. In short, LonWorks technology offers a system level approach to interoperability and comprises a complete set of tools and products. Each intelligent field cabinet is a node on the network and has equal status to the other nodes. The heart of a LonWorks hardware device is the NEURON Chip, an integrated circuit that combines a sophisticated communications protocol, three microprocessors, a multitasking operating system, and a flexible input/output

scheme. The microprocessor in the field node can support advanced diagnostics and manage all the local building function. The node in the network can communicate with each other and can be approached and managed through a central station or by a personal computer.

This type of network further simplifies installation and maintenance, and increases the reliability of the system. Once a fire damage or a fault occurs, only the immediate area is affected, and the fire command station or a fault occurs, only the immediate area is affected, and the fire command station or any other man/machine interface location could maintain communication with any other field cabinet on the network loop by transmission of data in two direction.

Response if this type of network to a fire threat is very fast, because there is no need for a CPU to scan and process whole building systems. The intelligent field node recognizes the fire alarm within its own area and acts upon that event within the nodes.

## 3. Development of intelligent control module for conventional zone adapter

The various field devices in fire alarm system are composed of the various fire detectors with DI and AI I/O ports, special indicators with DI I/O port, and execution units with DO I/O ports such as bell, siren. The I/O ports have mainly DI and DO modules. Because the devices including the fire suppression and smoke suppression & exhaustion system have DIO (Digital input output) ports together, It is very important that intelligent DIO control modules are developed firstly for the compact design and easy installation. Thus, the DIO Module was developed. This LonMarks device is to provide four digital inputs and four relay outputs. The digital inputs can monitor dry contacts or 30VDC voltage inputs. Four relay contracts are rated at 2A continuous and 6A surge at 30VAC or 42VDC. Separate Status LEDS are provided for each input and output. Separate Hand/Off/Auto switches are provided for each relay output. The module operates from 18 to 24VAC or VDC.

Resident within the module is a powerful, configurable application program. The program includes a variety software function blocks (LonMarks objects) that define how module will function. Digital input/counter function blocks provide configurable debouncing, inversion, override, and heartbeat control in addition to time, count, and frequency-based processing control of the digital inputs. Digital Output functional blocks provide configurable debouncing, inversion, time-based processing, override, and heartbeat control of the digital outputs. Digital Encoder functional blocks encode up to four digital values to produce configurable digital and mode outputs. Analog function blocks perform configurable logic, math, or enthalpy calculations on two analog inputs to generate analog and digital outputs. Table 1 represents the specification of the developed intelligent control DIO module.

**Table 1. Specification of the developed intelligent control DI/DO modules**

ITEM	SPECIFICATION
Power input	Flexible (18-24VAC/DC)
I/O channels	4 Relay output 4 Digital input (5-30VDC) LEDs for each output
Internal Protection	Isolation by DC-to-DC converter
Transceiver Type	FTT-10A with blocking capacitors for compatibility with power channel

This module has two times channels than that of the LonPoint DIO module and the dimension of complete product is 7.5cm×11.5cm×4.0cm. Figure 1 shows the overview of the developed intelligent control DIO module [9].

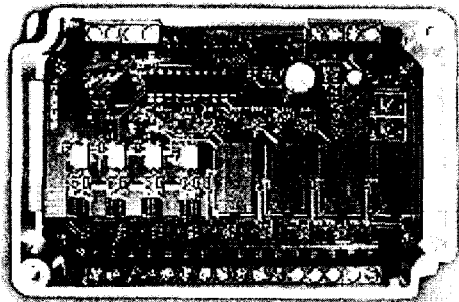

Fig. 1. Overview of the developed intelligent control module DIO

#### 4. Development of intelligent control modules with power line communication (PLC)

This intelligent control modules with the PLT-22 Power Line Transceiver is likely to be an essential part of any field bus system because provide the most ubiquitous wired connectivity and inexpensive way for data transmission and home automation applications. The PLT-22 transceiver complies with FCC, Industry Canada, Japan MPT, and European CENELEC EN50065-1 regulations for signaling in the 125kHz to 140kHz and 95kHz- 125kHz frequency band. The transceiver implements the CENELEC access protocol, which can be enabled or disabled the user. Intermittent noise sources, impedance changes, and attenuation make power line a hostile signal path. The PLT-22 transceiver operates reliably in the harsh environment through a novel Dual Carrier Frequency mode as well as custom digital signal processing (DSP), which provide adaptive carrier and data correlation, impulse noise cancellation, tone rejection and low overhead error correction. This innovation permits the transceiver to operate reliably in the presence of consumer electronics, power line intercoms, motor noise, electronic ballasts,

dimers, and other typical sources of interference. The transceiver communicates at a low bit rate of 5kbps. With the CENELEC protocol disabled, the transceiver has a maximum packet rate of 20 packets per second, With the CENELEC protocol enabled, the transceiver has a maximum packet rate of 18 packets per second. This high throughput makes the transceiver well suited for residential, commercial, and industrial automation application. The transceiver's power amplifier includes a selectable 3.5V peak-to-peak (p-p) or 7V p-p mode maximum communication performance. The 1Ω output impedance and 1A p-p current capability of the amplifier allow it to drive high output levels into lower impedance circuits, while the highly efficient design draws less total current than the previous transceiver. This increased output power improves signaling in all application and eliminates the expense of installing a phase coupler in typical residential applications. The net cost savings can be significant for home automation applications. The transceiver uses a low external coupling circuit and can communicate over virtually any AC or DC power mains, as well as unpowered twisted pair. The PLT-22 transceiver can use all the same coupling circuit as PLT-21 transceiver. The PLT-22 transceiver is powered by user-supplied +8.5 to +16VDC and +5VDC power supplies

We are developed an intelligent valve embedded power line communication with LonTalk protocol. The types of control modules include AO, AI, DO, and DI. To test the reliable performance of this intelligent modules,

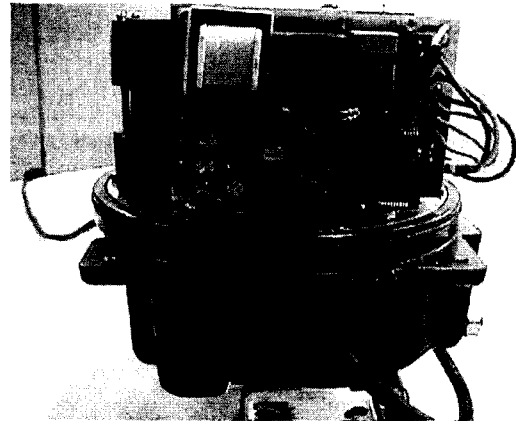

Fig. 2 Intelligent valve embedded power line communication with LonTalk protocol

Fig 3 shows the experimental board to test the performance of intelligent module with power line communication. The red character of 72.4 in the below of this board represents the valve drift manipulated by the data communication in 220 V AC power line. It is confirmed the testing results are very reliable, because the wide range of valve stroke is linearly operated in accordance with AI signal of sensor.

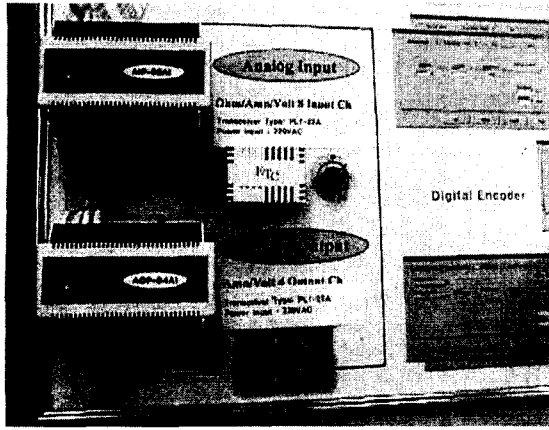

Fig. 3 Experimental board for testing the intelligent devices with PLC

### 5. Open network configuration for fire alarm signaling Systems

An open distributed fire detection system can be divided into types according to topological structure. The first one is composed of the various field devices including various fire detectors, manual call points, special indicators and execution units of fire fighting system. The second one is usually composed of the control units, which are connected with the field devices, providing the interface of man-machine conversation for monitoring and testing. The third one is the center of the whole system, monitoring the alarms, sending off control signals. Providing interface to security systems, building automation systems and city fire alarm network system. Fire alarm systems are usually composed of several kinds of units, such as central management unit, field device control unit, repeater control unit, remote communication control unit, and remote printer unit etc. Various units have separate functions. The network interconnects the units to accomplish a complete task. The internal network of the system is LonWorks, a kind of fieldbus network based on LonTalk protocol developed by Echelon Co. in 1993. LonTalk protocol follows ISO/OSI reference model for network protocol and operate as national standard of ANSI/EIA 709.1. The protocol has been integrated in the Neuron Chip named neuron 3120, and 3150 Chip [9]. The nodes using Neuron Chip for controlling can be communicate with the other nodes on the same network via the network variables.

The structure of the fire alarm system is very flexible. The topological structure of the network can be changed according to the structure of protected area. The network structure can be compacted mode, distributed mode, or mixed mode of both. The control unit in the system can be connected directly with twisted pair when compact mode is adopted, and transmission rate is 78kbps. Communication network can be realized using various transceivers through media, such as twisted pair, power line, optical fiber, when distributed mode is adopted. A router is necessary in order to connect the compact part with the distributed part when the mixed mode is

adopted.

### 5.1 Scale of fire alarm system for building size

The fire alarm systems are designed and installed according to the building size, use and placement type. A type of buildings is generally divided into a small scale (below 20 floor), a medium scale (21 -100 floor), High rise building (100 floor over) and a complex buildings with the multi-function Table 2 shows the scale of fire alarm system considering the building size.

Table 2. Scale of fire alarm system according to building size

SCALE OF BUILDING	NUMBER OF ADDRESSABLE DEVICES	NUMBER OF COMMAND CENTER/DATA GATHERING UNIT
small scale	600	1/0
medium scale	3000	1/30
high rise	3000 over	2/30(over)
complex type	Networks	1 (per building)

### 5.2 A distributed intelligent fire detection system for a small scale buildings

For configuring a fire detection system of a small scale buildings, A 1.25Mbps LonTalk backbone is used to connect 78Kbps control channels to each other. Two networks is connected by a LPR-12 router. Here, control channel is composed of the free topology and power line communication network. The control channels with over 64 nodes can enlarge the communication distance by using LPR-10 router. The distributed fire detection system based on LonWorks technology is illustrated in Fig. 4.

An intelligent node of DIO control module can locally detect the fire signal and execute the pertinent control command definitely. Because this communication type is serial digital packet, the systems have very excellent characteristics in the various noise environments.

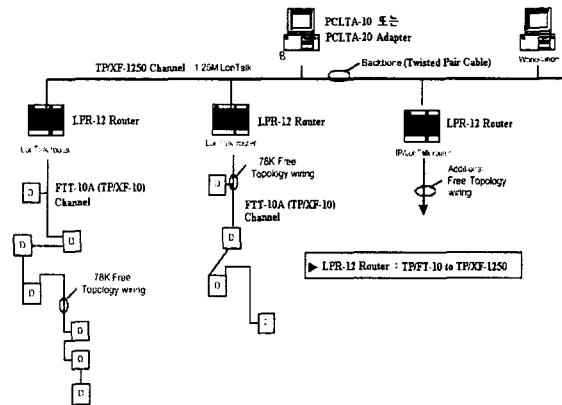

Fig. 4 A small scale configuration of LonWorks network fire alarm signaling system

### 5.3 A conceptual configuration of distributed intelligent fire detection system for large (high rise) scale buildings

In this architecture, IP channel run throughout the building automation and control system. The control and data networks are completely integrated. A 10Mbps Ethernet backbone is used to connect 1.25Mbps control channels to each other. Two network is connected by a IP/LonTalk router (i-LON) or CoActive server. A control channel can be composed of two type networks with 1.25Mbps and 78Kbps data communication rate or 78kbps data rate. System designer should select the control network type according to the size and the data network situation of building. Ethernet backbone LAN cable is used by an exclusive or office automation (OA) LAN for solving traffic problem of data communication. After calculating Ethernet 10Base-T Port required for every several floor of buildings, System designer should select the itching hub with 12-24port located at every floor of buildings is connected to IP/LonTalk Router. They are connected by UTP or fiber optical fiber cable among switching hub. This exclusive LAN backbone can assure the bandwidth of a transmission channel and guarantee the network reliability.

We have designed an example application system of fire alarm system using LonWorks network. The network system consists of two LonWorks ring-type networks, one is a twisted pair ring type network connected with main control computer, standby control computer and alarm control unit. The other is a fiber-optic ring type network connected fire alarm control units of the stations. These two parts are connected with a router. The system is a distribute network system. The control unit of the station is a compacted mode fire alarm system. Each control unit is composed of a central management unit, field devices control unit and a repeater control unit. The control units are interconnected by the fiber-optic transceiver. Each node of system can communicate with other nodes by peer to peer mode. The control center can get all the information within the network and save it to the system database and sends commands to the control units. The fire alarm control units can work in network mode, performing the orders of the control center, and it also can be independently when network failed. Fig. 5 shows a designed example of the alarm system configuration. Conceptual configuration of LonWorks network for distributed fire alarm systems is represented in Fig. 6

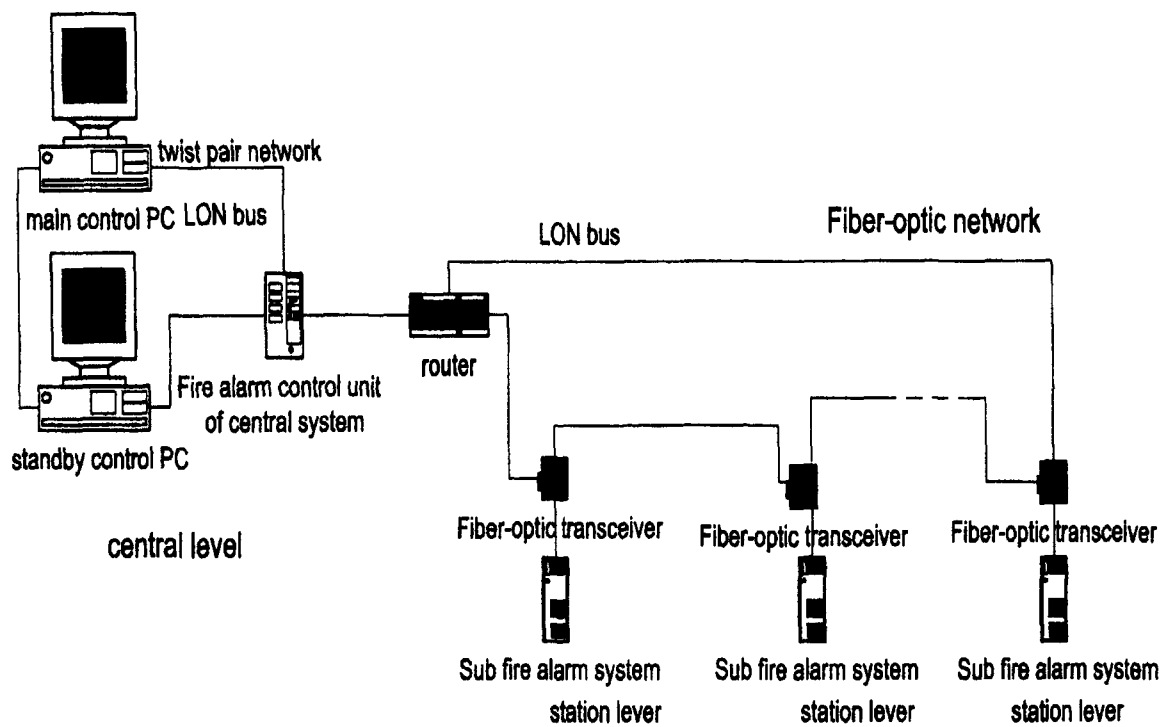

Fig. 5 An designed example of fire alarm system configuration

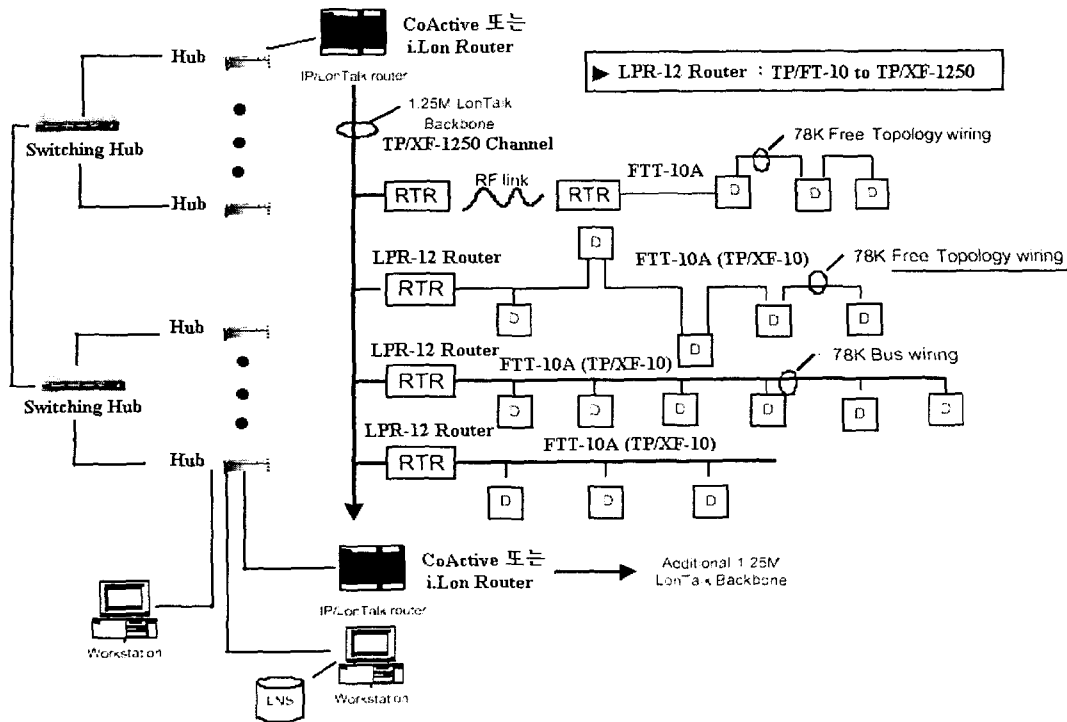

Fig. 6 Conceptual configuration of LonWorks network for distributed fire alarm systems

#### 5.4 Remote access by web technology

Remote monitoring and control also has the potential to improve fire safety. It is estimated that 67 percent of all fire occur outside of office hour. Remote monitoring of fire detection and alarm systems can reduce response time and improve response effectiveness by providing adequate fire information to the building supervisor, activating fire suppression systems and immediately summoning the appropriate fire bridge.

LonWorks network of fire detection systems can easily configure a remote control system connected to extranet, intranet and WAN(wide area network). IP/LonTalk Router is an important Internet server which integrate/ connect between the data network (LAN, WAN) and LonWorks network.

Remote fire detection and alarm system configured by LonWorks network is shown in Fig. 7.

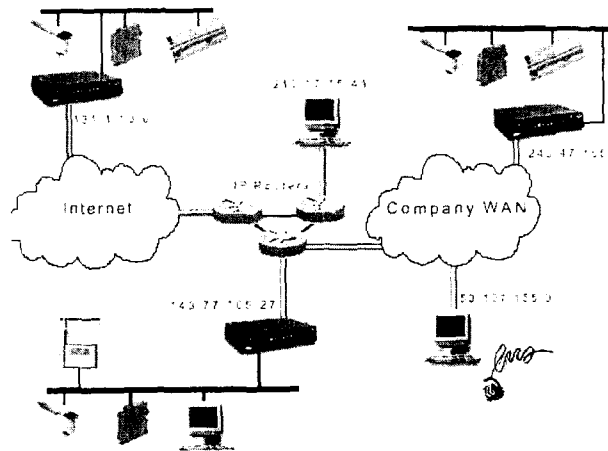

Fig. 7 Conceptual configuration of remote fire detection and alarm system based on Web

The distributed intelligent fire detection system will perform automatic fault detection and diagnosis with early warning of sensor contamination before the overall integrity of the system is affected. Overall processing of fire detection data including the moving image data by CCTV should permit more efficient discrimination between fire and non-fire threats. Furthermore, using Internet technology has the advantage, Wireless LAN technology or next generation mobile communication like an IMT2000 can easily be integrated into the future alarm system architecture because it is for sure that these new technologies will support the transport of IP package and Internet technology in general.

## 6. Results and discussion

Intelligent DIO control module using LonTalk protocol of ANSI/EIA 709.1 is developed to replace the conventional zone adapter and also an intelligent device based on LonTalk protocol for PLC. This development of intelligent device is a key technology to integrate BAS, because the intelligent nodes with a standard communication protocol provide the opportunity to integrate the closed fire detection and alarm system in BAS and exchange the data with other sub-systems such as HVAC and access control system. A standard communication protocol is crucial. We also propose a novel design for a distributed fire alarm system based on the LonWorks network and Internet respectively. This architecture which recognizes the fire alarm within its own area and acts upon that event within the nodes reduce false alarm, response time and fire-related losses. The proposed real-time control via the Internet will extend the monitoring and control of building service systems and fire safety out of the building, which will increase the efficiency and reduce costs for building management operation, more efficiently discriminate between fire and non-fire threats, and increase the time available for property and life protection. The integration of fire detection and alarm systems should also increase fire safety in the building. However, the application of intelligent building technology may also bring about new risks. Sensor technologies will need to be robust enough to prevent false alarms, accurately discriminate between fire and non-fire threats, and ensure that vital information such as the location of occupants is not lost due to data overload during the fire. IBS will need to be designed not only to give fire safety priority over other building activities but also that fire emergencies do not crash the building system.

## 7. Acknowledgement

The authors wish to thank the Electrical Engineering & Science Research Institute for their support in producing this paper.

## References

- [1] So, A. T et al., "Intelligent Building System" Kluwer Academic Publishers, Norwell, USA, 1999
- [2] W.P Hong, "Integration Trend of Intelligent Building System in view

- point of Open Building Automation System", Journal of KIIEE, Vol. 14, No. 2, pp. 13-27, 2000.
- [3] P. Madan, "Overview of Control Networking Technology", <http://www.echolon.com>.
- [4] ANSI/ASHRAE Standard 135-1995: A Data communication Protocol for Building Automation and Control Network. ASHRAE, Inc, 1793 Tullie Circle N.E., Atlanta, Georgia 30329-2305.
- [5] Buckley, J. B., "High-Rise Office Building Fire Safety System", ASHRAE Transactions, pp. 657, 1985.
- [6] S.T. Bushby, "Integration Fire Systems with Other Building Automation and Control System", NISTIR 6588, Vol. 2, March 1-7, 2000.
- [7] Z. Liu et al., "Development of Fire Detection Systems in the Intelligent Building", NIST SP 965, Feb. 2001.
- [8] W.P Hong et al., "A Novel Design of the Distributed Fire Alarm Control System by Developing Intelligent Control Modules with LonTalk Protocol", ICCAS 2001, Oct. 17-21, Cheju National Univ., Jeju Island, Korea, 2001.
- [9] Echelon Co., "Neuron C Reference Guide", 1999.
- [10] Echelon Co., "i-LON1000 Internet Server User Guide", version 1.0.
- [11] Echelon Co., "PLT-22 Power Line Transceiver Model 50090-03", <http://www.echolon.com>.