

Fatigue Strength of CRHS Joints Subjected to Out-of-plane Bending

Li-Chun Bian** , Yang Bae Jeon* , Ho Cheol Yoon* and Jae-Kyoo Lim**

**Graduate School, Chonbuk National University,*

***Department of Mechanical Design, Automobile Hi-Technology Research Institute*

College of Engineering, Chonbuk National University, Chonju, South Korea

Fax: (82) 63-2702460, E-mail: jklim@moak.chonbuk.ac.kr

ABSTRACT

This is a partial report of the investigation of fatigue behaviour of hollow section T-joints with circular brace members and rectangular chord members (CRHS). Hot spot stresses and the stress concentration factors (SCFs) were determined experimentally. Fatigue testing was carried out under constant amplitude loading in air. The experimental SCF values for CRHS joints were found to be below those of circular-to-circular (CCHS) and rectangular-to-rectangular (RRHS) hollow section joints. The fatigue strength referred to experimental hot spot stress was in reasonably good agreement with current fatigue design codes for tubular joints.

INTRODUCTION

Hollow sections are frequently used as structural elements. For offshore structures which are subjected to fatigue by wave loading, circular hollow sections are used almost exclusively due to their relatively smaller hydrodynamic loads and stress concentrations in joints. Rectangular hollow sections have a simpler geometry for joint fabrication, but larger stress concentrations and are frequently used for onshore structures and structures which are predominantly subjected to static loads. Joints with circular braces and rectangular chords (CRHS) may in many applications provide an optimum solution with a simple joint geometry for fabrication and a relatively smaller stress concentration factor compared to RRHS joints. However, a study of the available literature reveals that there is a little information and virtually no design guidance available for CRHS joints. In the present study, fatigue behaviour of CRHS joints subjected to out-of-plane bending loading was investigated. The results obtained were compared with design guidance for RRHS and CCHS structures. The work was undertaken in order to provide a data base, which could be developed into a design guidance for fatigue design of CRHS joints.

EXPERIMENTAL DETAILS

The material of the brace and chord members was steel to Standard DIN 17100. Figure 1 illustrates a typical T-joint geometry used in the present experiments. Table 1 presents the dimensions of specimens. The specimens were fabricated locally by manual electric metal arc welding. The welding procedures were the same as for offshore applications, with full penetration welds. The brace member was located at the mid section of the chord. In the present investigation, six specimens were tested with out-of-plane bending moment. Each specimen was rigidly clamped at both ends of the chord. Static and fatigue loads were applied by loading at the end of the brace. The models were instrumented with strain gauges. Strains were measured in the static tests prior to fatigue loading. Loading was applied by a computer controlled servohydraulic actuator system operated in load control.

Prior to fatigue testing, all the specimens were instrumented with strain gauges to allow for the measurement of hot spot strains in both the brace and the chord. Due to the relatively small dimensions of the joints, gauges of 1 mm length were used. Strains were measured along extrapolation lines (0° , 45° and 90°) on both the brace and the chord as shown in Fig. 2. Along each extrapolation line two strain gauges were located at distances 4 and 6 mm from the weld toe, respectively. A third gauge was located at a further distance of $1.0t/1.0T$ from the weld toe. The measured values were fitted to a quadratic curve using the least squares method, to obtain the strain gradient towards the weld toe. Hot spot strain was determined by extrapolating the measured strain values to the weld toe according to the DnV (1990) and ECSC (Radenkovic, 1981) definitions of hot spot strain for tubular joints and by the quadratic extrapolation method (van Wingerde, 1992).

On the basis of measured SCF values for the joints, fatigue testing was carried out with constant amplitude sinusoidal loading in air, test frequency in the range 8.0 - 10.0 Hz. The load ratio was $R = -0.36$. In order to evaluate the influence of geometric parameters on fatigue strength, all the joints were tested at an ECSC (Radenkovic, 1981) hot spot stress range $\Delta S_{HS} = 300$ MPa. Before commencing a test both the brace and the chord

were sealed and pressurised to 1.5 bar. Detection of fatigue crack initiation was carried out visually by spraying white spirit on the surface of the joint. Initial cracks could be detected by observing the pumping of liquid in and out of the crack in phase with the loading. In most of the cases the initial cracks were detected when they were very small with a depth of the order of 0.5 mm or less. By continuously monitoring the pressure, through-thickness cracking (N_3) could be detected with good accuracy.

DISCUSSION AND CONCLUSIONS

After determining the hot spot strains the stress concentration factors at the weld toe in both the brace and the chord for each specimen were determined by using the following equation,

$$SCF = \frac{S_{HS}}{S_{nom}} = \frac{E \cdot \epsilon_{HS}}{S_{nom}} \quad (1)$$

Note that the actual cross section of the brace was used in the determination of the nominal stresses (Brace nominal stress range, ΔS_{nom} = hot spot stress range / max. experimental SCF of a joint).

In Table 2 the maximum experimental SCF values and SCFs calculated from parametric formulae are compared. It should be noted that the UEG (1985) and the DnV (1990) formulae were derived for CCHS joints, whereas the van Wingerde (1992) formula is valid for RRHS joints. The Soh and Soh (1989) formula was derived for joint geometries with square brace members and circular chords, i.e., the opposite configuration compared to the present study. It can be seen from Table 2 that the RRHS joints have in general much larger stress concentration factors compared to the CCHS joints. It is very interesting to note that the experimental SCFs of CRHS joints exhibit a substantial improvement compared to those of both CCHS and RRHS joints. The Soh's formula, which was based on finite element analysis, appears to be suitable for CRHS joints and can be used to predict SCFs for CRHS joints.

In order to correct for the thickness effect, the following equation was used,

$$N_t = N_o (t_o/t)^{0.75} \quad (2)$$

where N_o is fatigue life for plate thickness t_o .

The experimental fatigue data normalized to 16 mm thickness using Eq. (2) are shown in Fig. 3 for direct comparison with the DEn design curve and associated scatter band for tubular joints (Gurney, 1982). All the experimental data fall above the design SN curve. However, the mean value of N_3 is now below the mean SN curve for 16 mm tubular joints. It should be noted that the data base underlying Eq. (2) is from tests with plate thickness in the range 12 mm and above. The application of Eq. (2) for specimens with wall thickness in the range 6.3 - 10 mm is beyond the normal validity range for this equation. Due to the combination of a simple weld geometry and an improved fatigue strength compared to rectangular-to-rectangular hollow sections, CRHS joints may provide an optimum solution for some structural applications.

REFERENCES

- Det norske Veritas (DnV) 1990. "Rules for the Design, Construction and Inspection of Fixed Offshore Structures", Norway.
- Gurney, T.R. 1982. "The basis of the revised fatigue design rules in the Department of Energy Offshore Guidance Notes", *Second International Conference on Offshore Welded Structures*, Cambridge, UK.
- Radenkovic, D. 1981. "Stress Analysis in Tubular Joints", *Proceedings of International Conference of Steel in Marine Structures*, Institut de Recherches de la Siderurgie Francaise, Plenary Session, pp. 53-96, Paris, France.
- Soh, A. K. and Soh, C. K. 1989. "SCF Equations for T/Y and K Square-to-Round Tubular Joints", *Journal of Petroleum Technology (JPT)*, pp. 289-296, March.
- UEG Publications 1985. "Design of Tubular Joints for Offshore Structures", UR33, London, UK.
- van Wingerde, A. M. 1992. "The Fatigue Behaviour of T- and X-joints Made of Square Hollow Sections", Heron, Vol. 37, No. 2, Delft, Netherlands.

Table 1. Dimensions of specimens

Specimen No.	Brace			Chord		
	d (mm)	t (mm)	l (mm)	B (mm)	T (mm)	L (mm)
T1OPB	82.5	6.7	900	200	10.0	720
T2OPB	51.0	8.7	900	180	10.0	720
T3OPB	160.0	6.3	900	200	6.3	1000
T4OPB	82.5	6.7	900	200	10.0	1000
T5OPB	140.0	8.7	900	200	10.0	1200
T6OPB	160.0	6.3	900	200	6.3	1200

T: T-joint, OPB: out-of-plane bending loading.

Table 2. Maximum experimental and parametric SCFs for each joint

Specimen No.	Exp.	UEG	DnV	Gibst	Wingerde	Soh
T1OPB	2.98	4.36	4.62	4.62	8.82	4.07
T2OPB	2.06	3.50	3.93	3.93	4.65	3.00
T3OPB	5.58	14.8	10.6	10.6	23.8	7.35
T4OPB	3.87	5.66	6.01	6.01	11.5	4.88
T5OPB	4.29	8.86	7.54	7.54	15.6	5.09
T6OPB	6.73	17.9	12.8	12.8	28.7	8.85

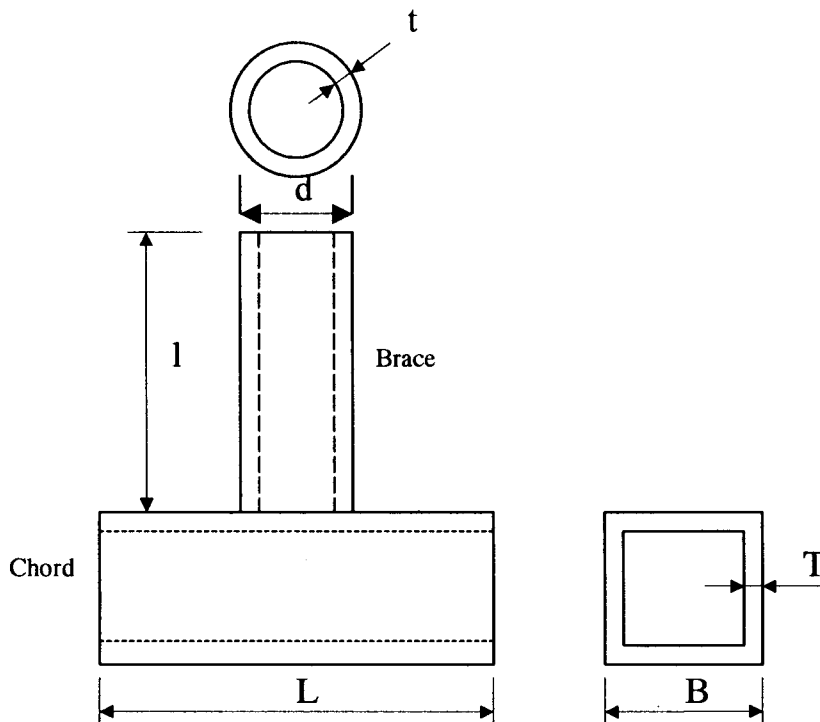

Fig. 1. Geometry of a CRHS joint.

where $\alpha = L/B$, $\beta = d/B$, $\gamma = B/2T$ and $\tau = t/T$.

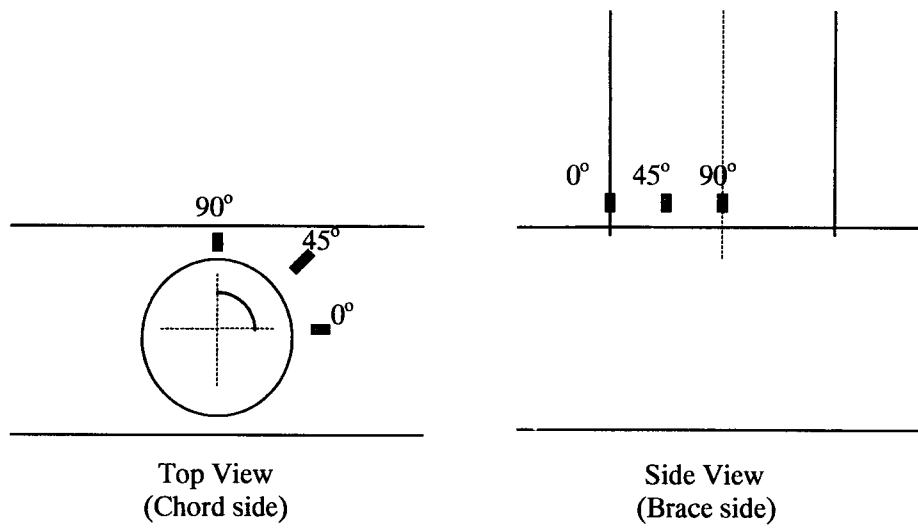

Fig. 2. Location of strain gauges.

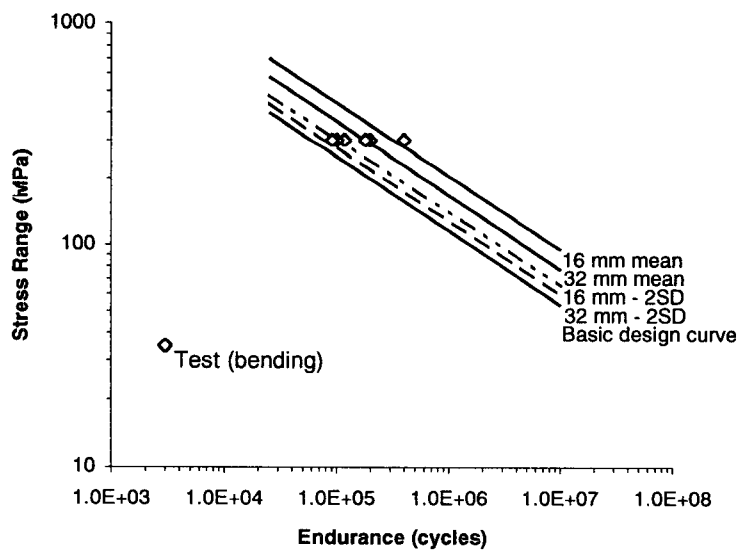

Fig. 3. Experimental data N_3 normalised to 16 mm thickness using Equation (2) compared with DEn design curve and associated scatter band for tubular joints.