

A Simple Spatial Scheme for Adaptive Antennas in CDMA Systems

Pham Van Su, Le Minh Tuan and Giwan Yoon
 Information and Communications University (ICU), 58-4 Hwaam-dong,
 P.O. Box 77, Yusong-gu, Daejeon 305-732, Korea
vansu_pham@icu.ac.kr

Abstract

A new simple spatial scheme for base station with adaptive antenna in Code Division Multiplexing Access (CDMA) systems is presented. In the proposed scheme, by applying the new spatial structure for the receiver, the system can debate the problem of which the number of users exceeds the number of adaptive antenna elements existing in the conventional spatial scheme. An adaptive algorithm based on the Mean Square Error (MSE) criterion is also derived to update the weight matrix of the proposed scheme. The results of the system capacity enhancement can be achieved by using the proposed approach. Numerical simulations are included for illustration and verification.

I. Introduction

Recently, the high-speed data service in wireless communication has demanded to enlarge the system capacity and improve spectrum utilization. The use of multiple antennas and spatial signal processing [1] (referred to as adaptive antennas, smart antennas, antenna arrays) in CDMA systems has been known as a promising system capacity enhancement approach. Most of adaptive antenna schemes proposed in the literature are spatial structures, *i.e.* based on space-only processing, which assume that the total number of paths from the signal and interference are less than the number of elements. Unfortunately, in real CDMA systems the assumption seems to be impractical. Thus, to obtain better resolution and interference cancellation, it generally needs to increase the size of the adaptive antenna array. As a result, the required computational burden and the base station complexity become two severe problems. A space-time extension of RAKE receiver is reported in [2] to overcome the problem. However, the base station is not simplified due to the complexity of RAKE receiver [3]. In this letter we propose a new simple spatial scheme for base station with adaptive antennas in CDMA system to solve the aforementioned limitation.

The paper is organized as follows. The system model and the signal presentation are given in Section II. In

the Section III, the computer simulation and some comments are demonstrated. Finally, the conclusion of the paper is given in Section IV.

II. Proposed Adaptation Scheme

The proposed scheme of a base station with adaptive antennas in CDMA systems is illustrated in Fig. 1. In the scheme, let us denote M as the number of signals impinging, K as the number of elements of adaptive antenna. At the transmitter side, the n -th data symbol, $d_i(n)$, of the i -th user is spread by Walsh code of length N , $\{c_{i1} \ c_{i2} \ \dots \ c_{iN}\}$, to get the spread signal vector $y_i(n)$ given below:

$$y_i(n) = \sum_{j=1}^N d_i(n)c_{ij} = [y_{i1}(n) \ y_{i2}(n) \ \dots \ y_{iN}(n)] \quad (1)$$

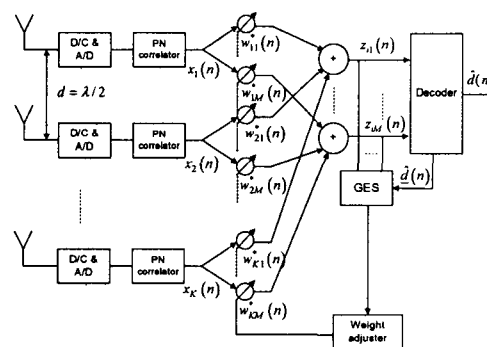

Fig.1 The proposed block diagram of a base station with adaptive antenna in CDMA system

At the receiver, we sample the received baseband signal $x_k(t)$ of the k -th element at the symbol rate T and consider that the interference from the undesired users is an unknown additive noise. Then, the received signal can be written as:

$$x_k(n) = \sum_{l=1}^L \alpha_l a(\theta_l) y_{k-\tau_l}(n) + n_k(n) \quad (2)$$

where L denotes the number of multipaths, $a(\theta_l)$ is the $M \times 1$ array response vector for the l -th path of the desired signal, α_l represents the amplitude reduction of the l -th path due to fading effect, τ_l is the delay spread of the l -th path, and $n_k(n)$ is sample of Additive White Gaussian Noise (AWGN). And, the received signal at the antenna of the base station can be denoted in a vector form:

$$\underline{x}(n) = [x_1(n) \ x_2(n) \ \cdots \ x_K(n)]^T \quad (3)$$

The received decision signal vector $\underline{z}_i(n)$ is achieved by multiplying the received signal vector the by weight matrix $\underline{W}(n)$, as follows:

$$\begin{aligned} \underline{z}_i(n) &= \underline{W}^H(n) \underline{x}(n) \\ &= [z_{i1}(n) \ z_{i2}(n) \ \cdots \ z_{iM}(n)]^T \end{aligned} \quad (4)$$

where T and H represent transpose and the complex conjugate transpose of a matrix or vector, respectively. The weight matrix is defined as follows:

$$\begin{aligned} \underline{W}(n) &= [\underline{w}_1(n) \ \underline{w}_2(n) \ \cdots \ \underline{w}_K(n)]^T \\ \underline{w}_j(n) &= [w_{j1}(n) \ w_{j2}(n) \ \cdots \ w_{jM}(n)] \\ &(j = 1, 2, \dots, K) \end{aligned}$$

The received decision signal vector is then fed into a majority logic decoder to get the original data symbols that are sent from the transmitter. Herein, we present $\hat{d}(n)$ and $\underline{\hat{d}}(n)$ as the desired data

symbol and the corresponding desired data vector at the output of the decoder, respectively. The desired data vector is constructed as follows:

$$\underline{\hat{d}}(n) = d(n) I_{M1} \quad (5)$$

where I_{M1} is an $M \times 1$ matrix whose elements are 1.

The MSE-based adaptive algorithm is to find out the optimum solution, which minimizes the following cost function [4]:

$$J(n) = E[|\underline{W}^H(n) \underline{x}(n) - \hat{d}(n)|^2] \quad (6)$$

In general, the optimum solution is determined at a location where the gradient of the function goes to zero. The gradient of equation (6) with respect to the weight matrix $\underline{W}(n)$ is given by:

$$\nabla J(n) = 2E[\underline{x}(n) \underline{x}^H(n) \underline{W}(n) - 2E[\underline{x}(n) \hat{d}^H(n)]] \quad (7)$$

And an optimum solution [4], which minimizes the cost function, is:

$$\underline{W}(n+1) = \underline{W}(n) - \frac{1}{2} \mu \nabla J(n) \quad (8)$$

In the equation (7), we use the instantaneous estimations, *i.e.*, the expectation operators are removed. Then, by substituting the equation (7) into the equation (8), we have:

$$\begin{aligned} \underline{W}(n+1) &= \underline{W}(n) - \mu \underline{x}(n) \{ \underline{x}^H(n) \underline{W}(n) - \hat{d}^H(n) \} \\ &= \underline{W}(n) - \mu \underline{x}(n) \underline{e}^H(n) \end{aligned} \quad (9)$$

where μ , $0 < \mu < 1$, is the step size, and the instantaneous error vector $\underline{e}(n)$ is the difference between the desired signal and the received decision signal, $z_{ij}(n)$, $j = 1, 2, \dots, M$, defined in the following equations:

$$\begin{aligned} \underline{e}(n) &= [e_1(n) \ e_2(n) \ \cdots \ e_M(n)]^T \\ &= \underline{z}_i(n) - \underline{\hat{d}}(n) = \underline{W}^H(n) \underline{x}(n) - \underline{\hat{d}}(n) \end{aligned} \quad (10)$$

or:

$$e_l(n) = z_{il}(n) - \hat{d}(n) \quad (l = 1, 2, \dots, M) \quad (11)$$

III. Simulation results

First, let us define some conditions and parameters for the simulation. The base station scheme in Fig.1 is employed for simulations to verify the performance of the proposed approach. The processing gain is assumed to be 64, the modulation scheme used for this simulation is BPSK. The Direction of Arrival (DOA) of the desired user is initialized at 30° , the DOA of the undesired users are randomized.

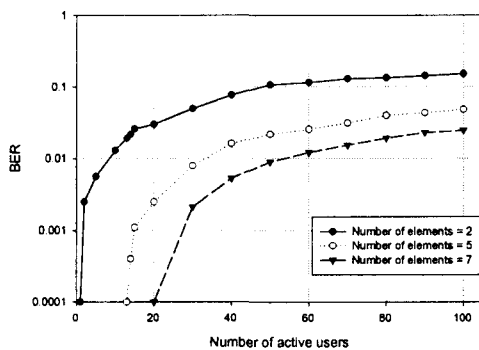

Fig.2: Performance of the proposed approach in term of BER versus the number of active users when the number of elements is changed.

The BER performance of the proposed approach when the number of active users increases is shown in Fig.2. As can be seen from the figure that when the number of active users increases, the BER of the system severely increases and the BER performance of the systems degraded more rapidly when the number of elements is small. However, with a slightly increase in the number of elements, the system performance is significantly improved. For instance, when the active user number increases to 20, the BER of the systems are 3×10^{-2} , 2.5×10^{-3} , and 1×10^{-4} for the number of elements are 2, 5, and 7, respectively.

IV. Conclusion

In conclusion, a simple scheme for base station with adaptive antennas in CDMA systems enclosed with an MSE-based adaptive beamforming algorithm has been addressed. It seems to more effectively overcome the limitation of the number of active

users in the real system, as compared to the number of arrays elements.

References

- [1] Avogiyaswami J. Paulraj and Coustantinos B. Papadias, "Space-Time Processing for Wireless Communications", IEEE Signal Pro., pp.49-83, Nov. 1997
- [2] A. F. Naguib, A. Paulraj, and T. Kailath, "Performance of CDMA cellular networks with base-station antenna arrays: the downlink", Communications, 1994. ICC'94, SUPERCOMM/ICC'94, Conference Record, 'Serving Humanity Through Communications', IEEE International Conference on, vol.2, pp. 795-799, 1994
- [3] J. G. Proakis, Digital Communications, McGraw-Hill, 2000, 4th ed.
- [4] S. Haykin, Adaptive filter, Prentice Hall, 2001, 5th ed.