

**유전자 알고리즘으로 최적화된 Pseudo-on-line 방법을 이용한 하이브리드 유도전동기 제어**

\*장경원, \*김진현, \*안태천, \*\*James F. Peters  
\*원광대학교 공과대학 전기전자 및 정보공학부.

\*\*Department of Electrical and Computer Engineering, University of Manitoba,

**Genetically Optimized Induction Motor Control with Pseudo-on-line Method**

\*Kyungwon Jang, \*Jinhyun Kang, \*Taechon Ahn, \*\*James F. Peters

\*School of Electrical Electronic & Information Engineering, Wonkwang University

\*\*Department of Electrical and Computer Engineering, University of Manitoba,

**Abstract** - This paper introduces a hybrid induction motor control using a genetically optimized pseudo-on-line method. Optimization results from the use of a look-up table based on genetic algorithms to find the global optimum of a un-constraint optimization problem. The approach to induction motor control includes a pseudo-on-line procedure that optimally estimates parameters of a fuzzy PID (FPID) controller. The proposed hybrid genetic fuzzy PID (GFPID) controller is applied to speed control of a 3-phase induction motor and its computer simulation is carried out. Simulation results show that the proposed controller is performs better than conventional FPID and PID controllers. The contribution of this paper is the introduction of a high performance hybrid form of induction motor control that makes on-line and real-time control of the drive system possible.

**1. Introduction**

Electric-power vehicles use a variety of motor drive systems. The recent introduction of multi-purpose electric vehicles indicates that both ac induction and brushless DC motors are gaining in popularity for traction motor applications [1]. The induction motor control problem has been widely studied with the objectives of obtaining better results in terms of stability, robustness to parameters variation and disturbances rejection. The voltage or current and frequency are the basic control variables of the induction motor. Many algorithms have been employed to improve the performance of the induction motor control [2]

The 3-phase induction motor is a representative plant, and the conventional PID controllers are used extensively in its control [3]. They are inexpensive and very effective for simple linear systems. Use of these conventional controllers is often adequate when the non-linearity of process is mild and plant operations are constrained to small region at a nominal steady - state. The design of discrete-time fuzzy PID (FPID) controllers in various combinations results in a new fuzzy version of the result of the conventional PID controllers [4]. These controllers have the same

linear structure as the conventional PID controllers in the proportional, integral and derivative parts, but have non-constant gains, namely, the proportional, integral, and derivative gains are nonlinear functions of the input signals. The FPID controllers thus preserve the simple linear structure of the conventional controllers, and yet enhance the self-tuning control capability for non-linearity [5], [6].

In this paper, it is proposed a novel control method with the pseudo-on-line scheme that auto-tunes the parameters of controller by the genetic algorithm [7] that does not use the gradient and finds the global optimum of a un-constraint optimization problem, for the improvement and optimization of systems.

**2. Induction motor modeling**

As the stator or rotor is assumed to have symmetrical air gap, it is possible to express its voltage equations of the three-phase induction motor in stationary coordinates *as*, *bs* and *cs*, as follows [1],[8] :

$$v_{abc} = R_s i_{abc} + \frac{d\lambda_{abc}}{dt} \tag{1}$$

$$v_{abc} = R_r i_{abc} + \frac{d\lambda_{abc}}{dt} \tag{2}$$

where  $v_{abc}$ ,  $i_{abc}$  and  $\lambda_{abc}$  are instantaneous voltage, current and flux linkage vectors of the rotor and stator, respectively, in the stationary frame.

The *d-q* reference frames are usually selected on the basis of convenience or compatibility with the representations of other network components.

The stator and rotor flux linkage expressions in terms of the currents can be written compactly as follows [8]:

$$\begin{aligned} \lambda_{qs} &= L_s i_{qs} + L_m (i_{qs} + i_{qr}), \\ \lambda_{ds} &= L_s i_{ds} + L_m (i_{ds} + i_{dr}), \\ \lambda_{qr} &= L_r i_{qr} + L_m (i_{qs} + i_{qr}), \\ \lambda_{dr} &= L_r i_{dr} + L_m (i_{ds} + i_{dr}) \end{aligned} \tag{3}$$

where,  $L_s$  is stator leakage inductance,  $L_r$  is

rotor leakage inductance and  $L_m$  is mutual inductance.

The expression for the electromagnetic torque in terms of current as follows:

$$T_e = \left(\frac{3}{2}\right)\left(\frac{P}{2}\right)L_m(i_{qs}i_{dr} - i_{ds}i_{qr}) \quad (4)$$

The vector control of the induction motor[3] is a very accepted method when high performance of the system response is required.

The torque equation becomes as follows:

$$T_e = \frac{3}{2} \frac{P}{2} \frac{L_m}{L_r} (i_{qs}\lambda_{dr} - i_{ds}\lambda_{qr}) \quad (5)$$

where  $L_r$  is  $L_{lr} + L_m$  and  $P$  is the number of poles. As the  $\lambda_{qr}$  is set to zero, the torque is as follows:

$$T_e = \frac{3}{2} \frac{P}{2} \frac{L_m}{L_r} (i_{qs}\lambda_{dr}) \quad (6)$$

Then the torque component current  $i_{qs}$  is as follows:

$$i_{qs} = \frac{2}{3} \frac{2}{P} \frac{L_r}{L_m} \frac{1}{\lambda_{dr}} T_e \quad (7)$$

In this paper, the 3-phase induction motor is controlled using the pseudo-on-line method based on genetic algorithms. The pseudo-on-line method based on genetic algorithms contains the following steps:

Step 1. Coding of error, integral and derivative of error.

Step 2. Compute fitness value of the coding parameters.

Step 3. Reproduce and select string to create new mating pool.

Step 4. Generate new population by crossover and mutation of selection strings.

Step 5. Optimize fuzzy membership functions.

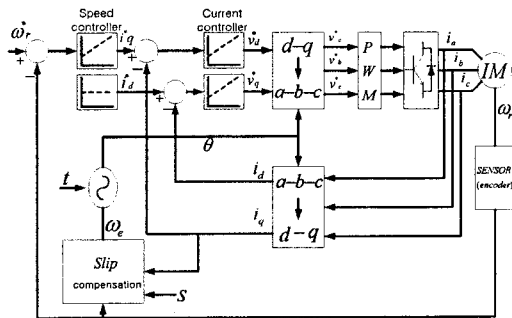

Fig. 1. Scheme of control system considered

The scheme of control system considered is like Fig.1. In Fig.1  $\omega_r$  is the rotor angular frequency,  $\omega_e$  is the stator angular frequency,  $S$  is the slip and  $\theta$  is the angle.

### 3.FPID control algorithm

In general, the control input  $u$  of the fuzzy controllers is decided by the proportional combination of error term and derivative term of error as eqn.(8). It corresponds to the PD of

conventional PID as eqn.(9).

$$u = \sum_{i=1}^k (\mu(e_i) \cap \mu(de_i)) \quad \langle \text{Fuzzy} \rangle \quad (8)$$

$$u(t) = k_p e(t) + k_d \frac{de(t)}{dt} \quad \langle \text{PD} \rangle \quad (9)$$

In this paper, to remove defects of the fuzzy controller, the direct FPID controllers are designed by using the conventional PD+I controller design method[11]. To obtain the increment of fuzzy control input, this method directly applies the control gains to PID control input concept. The fuzzy reasoning is executed using the eqn.(10).

$$du = k_p \cdot e + k_i \cdot ie + k_d \cdot de \quad (10)$$

The values of  $e$ ,  $de$  and  $ie$  are described as follows:

$$e_0 \leq e \leq e_m \quad (11)$$

$$de_0 \leq de \leq de_m \quad (12)$$

$$ie_0 \leq ie \leq ie_m \quad (13)$$

The fuzzy sets of  $e$ ,  $de$  and  $ie$  are described as Fig. 2:

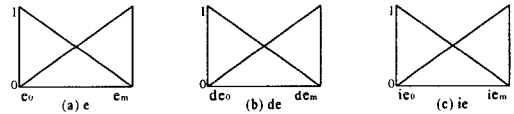

Fig. 2. Fuzzy sets of  $e$ ,  $de$ ,  $ie$

Each fuzzy rule can be described as follows by simplified fuzzy reasoning method.

- Rule 1 :  $e_0$  and  $de_0$  and  $ie_0 \Rightarrow f_1$
- Rule 2 :  $e_0$  and  $de_0$  and  $ie_m \Rightarrow f_2$
- Rule 3 :  $e_0$  and  $de_m$  and  $ie_0 \Rightarrow f_3$
- Rule 4 :  $e_0$  and  $de_m$  and  $ie_m \Rightarrow f_4$
- Rule 5 :  $e_m$  and  $de_0$  and  $ie_0 \Rightarrow f_5$
- Rule 6 :  $e_m$  and  $de_0$  and  $ie_m \Rightarrow f_6$
- Rule 7 :  $e_m$  and  $de_m$  and  $ie_0 \Rightarrow f_7$
- Rule 8 :  $e_m$  and  $de_m$  and  $ie_m \Rightarrow f_8$
- Fact :  $e$                        $de$                        $ie$

As the results of fuzzy reasoning, the output of fuzzy controller is described as follows:

$$f = du = \frac{f_{11} + f_{22}}{h_{11} + h_{22}} = f_{11} + f_{22} \quad (14)$$

$$= k_p \cdot e + k_d \cdot de + k_i \cdot ie$$

The output of fuzzy controller, that is, eqn. (14) is used as the control input of induction motor.

## 4. Auto-tuning methods

### 4.1 Heuristic algorithm

Fuzzy controllers achieve inferred values of the control inputs using triangular membership functions. Recent literature has suggested that other forms of input membership function can be used to provide different properties for the controller.

The change of fuzzy control in the fuzzy look-up table have much influence on the performance of a system.

A fuzzy model consists of a finite number of fuzzy implication rules. The fuzzy modelling is related to the construction of fuzzy rules based on a set of input reference command signal and output measurement. Using this input-output data set, fuzzy clustering separates this data set into several local sets so that it provides an accurate representation of the system's behavior.

In the paper, define the weighted objective function to appreciate the fitness of induction motor as eqn. (15)

$$F(k) = s(k) + \frac{1}{2} r(k) + 10 \frac{v_p(k) - v_{ref}(k)}{v_{ref}(k)} \quad (15)$$

where  $s(k)$  is settling time,  $r(k)$ , rising time,  $v_p(k)$ , maximum overshoot, and  $v_{ref}(k)$ , reference speed.

The heuristic method generally shows that the control system not only have a good response but also keep the stability of system. But this method need the expert with much information for induction motor.

#### 4.2 Genetic Algorithms

Genetic algorithms (GAs) [7] are directed to random search techniques, which can find the global optimal solution in complex multidimensional search spaces. GAs employ different genetic operators to manipulate individuals in a population of solution over several generations to improve their fitness, gradually. Normally, the parameters to be optimized are represented in a binary string.

To start the optimization, GAs use randomly produced initial solutions created by random number generator. This method is preferred when a priori knowledge about the problem is not available.

In this paper, to easily conduct the crossover operator, input variables are multiplied by 1000, roundoff the fractions, transformed into integer and converted to binary digital system. This integers become new input variables. Takagi's formula is used as the objective function that defined by function of input variables like eqn.(16).

$$F(k) = \sqrt{(e(k))^2 + de(k)^2 + ie(k)^2} \quad (16)$$

where  $e(k)$ ,  $de(k)$  and  $ie(k)$  is error, derivative of error and integral of error as input variables, respectively.

The number of populations use 10 and the number of chromosomes gain 20 through the conversion of five decimal places to binary. Selection of genetics uses probability theory and random variable. The crossover and mutation rates also use random variable. The algorithm is repeated until a predefined result has been produced.

Through the genetic algorithm, a look-up table is made of the optimized results and it is used to the On-line system. Each table consists of 125, 17000 and 1000000 databases that is divided into 5, 30 and 100 levels for each of input variables, that is,  $e(k)$ ,  $de(k)$  and  $ie(k)$ .

Each level is divided by proportion to the square of error for steady state. The scope of  $e(k)$  is chosen to set the difference between reference speed and initial speed as -100% and 100% overshoot as 100%. The scope of  $de(k)$  is chosen to set 1000 as 100% and -1000 as -100%, because  $de(k)$  approaches to infinity. The scope of  $ie(k)$  is chosen to set 1 as 100% and -1 as -100%, because  $de(k)$  is limited from -1 to 1.

When the number of levels increases, the excellent result can be obtained. But increasing levels cause that the performance is getting bad, owing to large computer capability and the low access speed. Therefore it is to be suitable to select levels between 30 to 100.

Heuristic algorithm that changes fuzzy control rule to the experience knowledge, have good performance in the steady-state error, but do not give so good performance in the transient-state error. The pseudo-on-line method provides good performances in the steady-state and transient-state errors.

#### 5. Simulations

Several simulations have been carried out to examine the feasibility of the proposed pseudo-on-line algorithm for induction motor system that is described as the type of fifth-order nonlinear differential equation. Using the Runge-Kutta method, the numerical solution was obtained.

$$\frac{d}{dt} i_m = \frac{-1}{L_s L_r - L_m^2} (R_s L_r i_m + \omega_s L_m^2 i_d - R_s L_m i_{qr} + \omega_s L_m i_{dr} - L_s V_m)$$

$$\frac{d}{dt} i_d = \frac{-1}{L_s L_r - L_m^2} (-\omega_s L_m^2 i_m + R_s L_r i_d - \omega_s L_m i_{qr} + R_s L_m i_{dr} - L_s V_d)$$

$$\frac{d}{dt} i_{qr} = \frac{-1}{L_s L_r - L_m^2} (R_s L_m i_m - \omega_s L_m i_d + R_s L_r i_{qr} - \omega_s L_m i_{dr} - L_s V_q)$$

$$\frac{d}{dt} i_{dr} = \frac{-1}{L_s L_r - L_m^2} (-\omega_s L_m i_m - R_s L_m i_d + \omega_s L_r i_{qr} + R_s L_m i_{dr} - L_s V_d)$$

$$\frac{d}{dt} \omega_r = \frac{3L_m}{2J} (i_m i_{dr} - i_d i_{qr}) - \frac{B}{J} \omega_r - \frac{1}{J} T_l \quad (17)$$

Torque equation can be as follows[8]:

$$T_e = \frac{3}{2} \frac{P}{2} \frac{1}{\omega_b} (\phi_{qr} i_{dr} - \phi_{dr} i_{qr}) \quad (18)$$

where  $\phi = \omega_b \lambda$ ,  $\omega_b = 2\pi f_{rated}$  electric radians per second and  $f_{rated}$  being the rated frequency in Hertz of the machine.

Voltage source frequency  $\omega$  can be related to the rotor frequency  $\omega_r$  as follows:

$$\omega_s = \frac{R_r L_m}{\phi_{dr} L_r} \cdot i_{qs} + \omega_r \quad (19)$$

Table 3 shows the rated values and the nominal parameters of a tested machine. Simulation results are depicted in Fig. 8 ~ 13, when the motor speed is changed from -600[rpm] to 600[rpm], applied the control techniques proposed in the previous section. In these figures, 30 levels case is compared for the given method in viewpoint of motor speed and torque component current. We use also eqn.(20) as performance index (PI) of induction motor.

$$PI = \int \sqrt{e^2} \quad (20)$$

where,  $e$  is error of motor speed.

Table 3. Motor Parameters

Normal Output	$P_0$	1.1Kw
Normal Rotational Frequency		1000RPM
Stator Resistance	$R_s$	0.2842 $\Omega$
Rotor Resistance	$R_r$	0.2878 $\Omega$
Stator Inductance	$L_{ls}$	0.02827H
Rotor Inductance	$L_{lr}$	0.02827H
Mutual Inductance	$L_m$	0.02682H
Leakage Coefficient	$\sigma$	0.116
Number of Pole Pairs	$P$	3
Moment of Inertial	$J$	0.0179Kg-m <sup>2</sup>
Stator Current	$I_{ds}$	15.4A
Stator Voltage	$V_{qs}$	137V
Natural Frequency	$W_n$	160 rad/sec
Damping Coefficients	$\delta$	0.539
Electrical Time Constant	$T_E$	5.37 msec
Mechanical Time Constant	$T_M$	6.73 msec

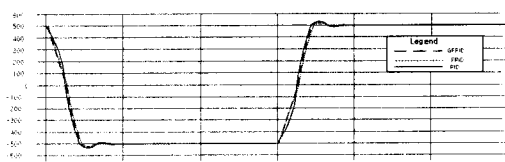

Fig. 3. Motor Speed (x-sec, y-rpm, load)

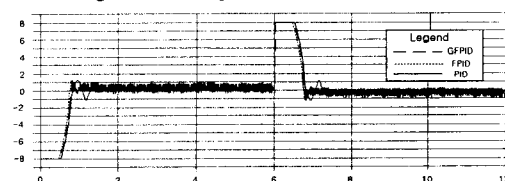

Fig. 4. Torque component current (x-sec., y-mA, load)

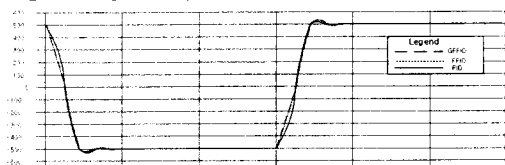

Fig. 5. Emulator output (x-sec., y-rpm, load)

As shown in Fig. 11~13 with load, the proposed controller has the same performance for the rise time and the performance index. But this method improves maximum overshoot and settling time. The torque component current has a little non-linearity, that is, the torque component current oscillates in the steady state. This is a general characteristic of powerful controller like fuzzy controller that the small errors occur the large reactions.

## 6. Conclusions

This paper proposed a novel method with the pseudo-on-line scheme using an optimized

look-up table based on the genetic algorithm that did not use the gradient and found the global optimum of a un-constraint optimization problem. The technique included the procedure that optimally estimated in off-line the parameters of FPID controller using the genetic algorithm, and made the optimized look-up table using the estimated parameters and controlled in on-line the systems with non-linearity at real-time. To prove the high performance, the proposed GFPC controller was applied to speed control of 3-phase induction motor and its computer simulation is carried out. Simulation results showed that the proposed controller is more excellent than conventional FPID and PID controllers. The control results of the GFPC controller are as follows:

1. The speed control of induction motor showed that the proposed controller gained optimal performance with load and no load obtained.

2. Through the division of the input parameter region and optimal look-up table, on-line real time control with off-line performance was possible based on genetic algorithm.

3. The proposed controller achieved better performance than conventional PID controllers. Especially, it showed the high performance of rising time, overshoot and settling time at transient state when the level of input variable increased.

4. The proposed controller with auto-tuning proved makes it is possible to control the speed for electric vehicles with drive system of induction motor.

## (References)

- [1] B. K. Bose, Power Electronics and AC Drivers, Prentice-Hall Book, 1986.
- [2] J. Cleland and W. Turner, "Fuzzy logic control of AC induction motor", IEEE Research Triangle Institute, pp. 843-850, 1992.
- [3] P. Vas, "Vector Control of AC Machines" Clarendon Press, Oxford, 1990.
- [4] Y. Yoshinari, W. Pedrycz and K. Hirota, "Construction of fuzzy models through clustering techniques", Fuzzy sets Syst., vol. 54, no. 2, pp. 157-165, 1993.
- [5] M. Mizumoto, "Realization of PID control by fuzzy control method", IEEE Division of Information and Computer Sciences, pp. 709-715, 1992.
- [6] W. C. Dangherity, B. Rathakrishnan and J. Ten, "Performance evaluation of a self-tuning fuzzy controller", IEEE Department of Computer Science Texas A & M University College Station TX 77843, pp. 389-397, 1992.
- [7] R. Caponetto, L. Fortuna, S. Graziani and M. Xibilia, "Genetic algorithms and applications in system engineering: a Survey", Trans. Inst. Meas. Control, vol. 15, pp. 143-156, 1993.
- [8] P. C. Krause, "Analysis of Electric Machinery", McGraw-Hill Book, 1987.
- [9] Y. F. Li and C. C. Lau, "Development of Fuzzy Algorithms for Servo Systems", IEEE Control System Magazine, Apr., pp.65-71, 1989.