

General Situation of Ginseng Cultivation and Research in China

Rongsheng Wang, Haozhe Lian and Fengyang Liu

Institute of Special Wild and Economic Animal and Plant Sciences, CAAS Zuoqiu, Jilin, P.R. China 132109

The Developing History of Ginseng Cultivation in China

Panax ginseng has been used as a valuable herb in China more than 4,000 years. It was reported that the wild ginseng distributed in Taihang Mountains were exploited initially. But there were few wild ginseng found in Taihang Mountains in Tang Dynasty since long-term overexploitation. The wild ginseng distributed in the Northeast of China was widely used after Taihang wild ginseng becoming extinct gradually. The wild ginseng range extends principally in the Northeast of China, especially in the Changbai Mountains, Da Xinganling and Xiao Xinganling Mountain systems nowadays. Big wild ginsengs which have grown over a hundred years are seldom.

Ginseng cultivation began about 1,600 years ago in China because of the great demand and the dwindling supply of wild ginseng. The earliest plantations occurred in Western Jin Dynasty (A.D. 255-316). While Ginseng was cultivated in the Northeast of China about 400 years ago.

The history of ginseng cultivation in China since late 1920s might be divided into three stages. The first stage from 1929 to 1948 is slowly developing stage. According to the historical records, the ginseng output was 750,000 kg in 1929 and dropped to 50,000 kg in 1939. Only 14,000 kg ginseng was harvested from about 28,000 m² ginseng farmland in 1948.

The second stage is steadily developing stage (from 1940 to 1979). The government of People's Republic of China pays a great attention to ginseng cultivation since 1949. The ginseng is planted not only in Jilin, Heilongjiang, and Liaoning in the Nor-

theast of China, but also in Beijing, Shandong, etc.. There are 23 state-owned ginseng farms and 4,000 villages of town-owned collective ginseng farms in Jilin province. The acreages under ginseng in Jilin in 1980 was 36 times as many as that in 1949 and the unit yield per square meter in 1980 increased 39 times than that in 1949. The unit ginseng yield was only 0.75-1.0 kg/m² because of the backward traditional culture methods adopted in cultivative practice before 1980.

The third stage is rapidly developing stage (from 1980 to 1989). Traditional culture methods have been transformed and series of modern techniques have been adopted during this stage. In 1988, the cultivated area increased 1.5 times and the total ginseng yield increased 10.5 times than those in 1980 respectively. In experienced ginseng farms, the average unit yield ranges from 2.0 to 2.5 kg/m². In some farms, the average unit yield may be as high as 3.0 kg/m² or more. In newly established ginseng farms, the average unit yield is 1.0-1.5 kg/m².

The Northeast of China is the largest ginseng cultivation area where ranges 40°51'-45°42'N and 125°15'-128°05' E. Jilin is the principal ginseng culture province. Fusong, Changbai, and Jian are the largest and most successful counties of growing ginseng. Ginseng is also cultured widely in counties of Tonghua, Dunhua, Linjiang, Huedian, Antu, Jiaohe, Huinan, Liuhe, Yanji, Lonjing, Wangqing, Huntrun, etc. In these counties of Yongji, Chulan, Dongfeng, Lishu, Nongan and Jiutai, the ginseng industry is growing very fast recently.

Kuandian and Huaiyen are the two largest counties of planting ginseng in Liaoning province. The ginseng cultivation has also been taken widely in

some 30 counties in Liaoning, such as Kinbin, Shuizhong, Qingyuan, Benxi, Zhuanghe, Dandong, Fengcheng, and Liaoyang, *etc.*

There are about 40 counties cultivating ginseng in Heilongjiang province where has become another ginseng production area.

The Present Situation of Ginseng Cultivation in China

Jilin is the main ginseng cultivative area. Its situation of ginseng cultivation represents the national situation in China. I would like to take Jilin as an example to introduce the ginseng cultivation in China.

I. Own mode of ginseng farms

1. State-owned mode: The earliest two state-owned ginseng farms were founded in Jian and Fusong county of Jilin province respectively in 1955. There are 23 state-owned ginseng farms and more than 100 province- or country-owned ginseng farms in Jilin province in 1980. New cultural methods and modern techniques are being practiced in these farms, which make them become backbone enterprises of Jilin ginseng production. The total cultivated ginseng area of these farms is about 1/6 of the total cultivated ginseng area in Jilin province.

2. Collective-owned mode: There are 4012 collective-owned ginseng farms which are operated by villages or towns in Jilin province in 1980. Ginseng farms might be almost found in every town and village in some mountain counties of eastern part of Jilin. The ginseng enterprise has been developed very fast recently and shown a picture of prosperity.

3. Individual-owned mode: The ginseng is cultivated by lots of farmers, especially who live in mountain areas. Planting ginseng makes those farmers wealthy. There are 27,123 individual ginseng farms in Tonghua, Liuhe, and Meihokou counties according to a survey carried on in 1987.

II. Ginseng types cultivated in China

Three special economic ginseng types (not

varieties) have been formed because of the differentiation of ecological environment and cultural methods.

1. Shizhu ginseng: Shizhu ginseng, also known as Zhusen, is produced only from Shizhu village in Kuandian county of Liaoning province. It is characterized by long rhizome, short main root, tough root cuticle with deep lines, needle like fibrous roots with pearl like grains. It takes about 15 years from planting to harvest when a big root weighs some 50g, a common root 30-35g, and a small root 20-25g. Shizhu ginseng is welcomed at home and abroad markets because of its beautiful bodily form.

2. Biantiao ginseng: It is produced especially in both counties of Jian and Tongliao in Jilin province as well as Huaiyen county of Liaoning province. It usually takes 7 to 9 years from planting to harvest. The biggest Biantiao ginseng root weighs 725g, a common one 100-250g. Biantiao ginseng is characterized as long rhizome and main root, two long lateral roots, few or no adventitious roots. Biantiao ginseng is also welcomed at home and abroad markets for its beautiful bodily form. Xinkaihe Red Ginseng processed with fresh Xiantiao ginseng won the golden prize at the 16th Geneva exhibition of world new invention and technology in Apr., 1988.

3. ordinary ginseng: It, known as ginseng, is cultivated mainly in Jilin, Liaoning and Heilongjiang provinces. Six years are needed from planting seed to harvest roots when a ginseng root weighs commonly 100-150g. While a bigger root weighs about 500g and a smaller weighs 20-30g. The ordinary ginseng, which is different significantly from Biantiao ginseng and Shizhu ginseng, make a feature of short rhizome and main root, shorter lateral roots, more adventitious roots and fibrous roots. The Changbai Shan Red Ginseng processed with ordinary ginseng won the golden prize at the exhibition of world invention in Belgium in 1987.

III. Principal Methods of Ginseng Cultivation

1. Solids: In most cultivative area, choose forestry land or wasteland to plant ginseng. Soils with high content of humus and well-drained are suitable for ginseng. It must be clear of stones,

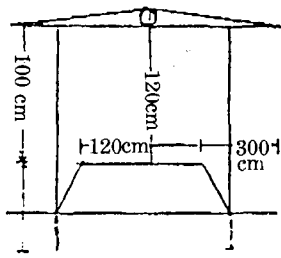

Fig. 1. Structure of flat-roof shade

shrubs, chunks of wood, tree roots and other obstructions after the site is settled. Turn up the soil frequently before one year of planting or transferring to kill the pathogenic bacterium and weeds.

2. Beds: A bed for planting ginseng is usually 25 to 30 cm high and 120-150 cm wide. Leave a 110-150 cm walkway between beds.

3. Periodic system of cultivation: The most frequently adopted periodic systems of cultivation are "3.3", "2.3", and "2.4", which mean that ginseng seedlings grow in nursery bed for two or three years and then are transplanted to transferring bed (permanent bed) to grow for another three or four years to harvest.

4. Sowing and transplanting: There are three sowing methods: dibbling, drilling, and disseminating. Dibbling is the best method among them because it has the advantages of saving and well-distributing seeds, even emergence of seedlings, favourable nutrients and water supply, and high seedling utilization ratio. Drilling is sparing in use of seeds and has the ginseng bed more ventilating compared to that of disseminating. But it cannot produce high grade seedlings because of uneven distribution of seeds and seedlings. Proper thinning is needed in order to raise high qualified seedlings. Dissemination has no advantages but saving labor compared with other two sowing methods.

Transplanting methods of ginseng seedlings might be divided into two types: level transferring and oblique transferring. By level transferring, ginseng seedlings are put levelly in bed. This method is adopted where soil is humid. By oblique transferring, ginseng seedlings are laid obliquely in bed. It is used where soil is frequently drought.

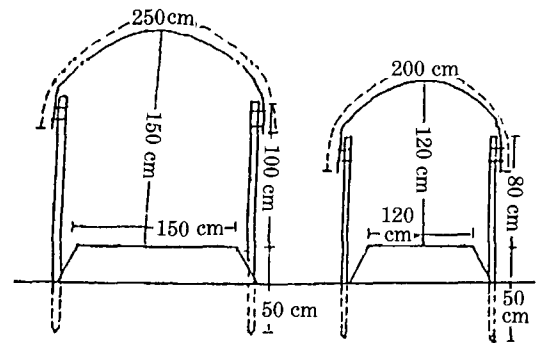

Fig. 2. Structure of bow-roof shade

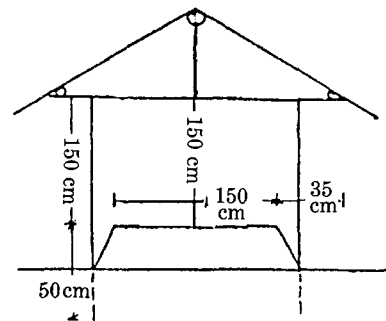

Fig. 3. Structure of spine-roof shade

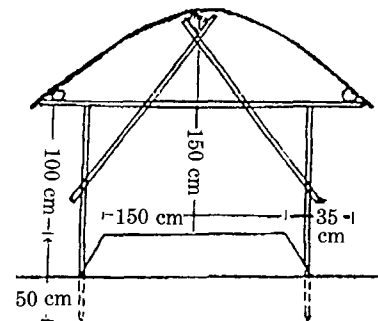

Fig. 4. Structure of arch-roof shade

5. Shading: Ginseng is a shade plant. Shade is imperative to keep the ginseng from strong sunshine and rainwater. The water-proof and sunlight-proof had been widely taken in ginseng cultivation in China before 1980 and it has been replaced by the shade of water-proof but sunlight passing since then. The water-proof but sunlight passing partly shade might be divided into flat-roof shade, spine-roof shade, and arch-roof shade, etc. (see Figs. 1-4).

The Advance of Ginseng Researches in China

Ginseng, being praised as the head of medicinal herbs, is reputed as a treasure or gem in China. It is a valuable nourishing medicine and is ranked a first in the known "Chinese Herbal Medicine 400".

After the founding of the People's Republic of China, the government has been paying a great attention to ginseng. The Institute of Pharmaceutical of Chinese Academy of Medical Sciences takes the ginseng for one of its research objects. The Institute of Special Wild Economic Animal and Plant Sciences of Jilin Province was established in 1956 (later it was put under the Chinese Academy of Agricultural Sciences), which has been engaging specially in ginseng researches. Many Institutes of Special Local Products or Ginseng have been also correspondingly set up in the main districts or counties of ginseng cultivation in Jilin Province. Lots of researches on ginseng are carried out not only in institutes, but also in some universities, such as Bethune University, the College of Traditional Chinese Medical Science and Medicine and so on. Therefore, it can be said that there have been a perfect research system and massive ranks of science and technology in ginseng industry, many researches have been made and lots of achievements have been gained. Now, I would like to discuss briefly a few questions of the cultivation technologies of ginseng.

I. The reform of the shading of ginseng

In China, the ginseng was almost shaded by the slope-roof shade of water-proof and sunlight-proof before 1980, which was made of board or straw, whereas by the flat-roof or spine-roof or arch-roof shade of water-proof but sunlight passing partly at present. The researches showed that there was a very unreasonable light status under the shade of the water-proof and sunlight-proof. The daily illuminance was changeable with a double peak curve. After the sun rising, the illuminance increased sharply up to 23500 Lux at 7-8 a.m., then dropped to 2000-4000 Lux and increased again up to 20000 Lux at 3-4 p.m.. Because of the illuminance being over strong or over-weak within a day, especially

the weak light for some 7 hrs from 9 a.m. to 3 p.m., the ginseng photo-synthesis, accumulation of organic matters, growth and development were affected under the shade of the water-proof and sunlight-proof. The yield of ginseng was usually less than 1.25 kg/m².

While under the shade of water-proof but sunlight passing partly, the daily illuminance is stable, which ranges from 9500 to 19600 Lux from 7 a.m. to 5 p.m.. Based on the results of experiments, the light compensation point of ginseng is 400 Lux. The ginseng photosynthesis rate rises sharply under 400-10000 Lux and slowly under 10000-33000 Lux. We considered that the suitable illuminance ranges generally from 3200 to 22000 Lux in Jilin province. Because the illuminance is more suitable and the light status is improved under the shade of water-proof but sunlight passing partly, ginseng photosynthesis is heightened and the accumulation of organic matters are promoted, which result in a high yield and quality of ginseng. Owing to the use of the shade of water-proof but sunlight passing partly after 1980, the yield of ginseng have increased year by year. In Changbai County, for example, the average yield of ginseng was 1.1 kg/m² by 1980, whereas 2.25 kg/m² for the whole country in 1986 and more than 3.0 kg/m² in recent years.

II. The improvement of the periodic system of cultivation

According to the traditional cultivation, "3.3" system was adopted in the ordinary ginseng cultivation and a "3.3.3" system in the "Biantiao" ginseng cultivation. At present, a "2.3" or "2.4" system has been popularized in the ordinary ginseng cultivation and a "2.2.3" system in "Biantiao" ginseng cultivation. Transplanting 2-year-old plants instead of 3-year-old plants shows many advantages: less years of raising seedlings, beneficial to the seedling growth; beautiful root bodily form, i.e. long main root with less fibrous roots and uniform, high seedling availability; less cuts as digging seedling because of less lateral roots; fast revivification of seedling after the transplant; lighter disease; and thus favourable to the plant growth in the subse-

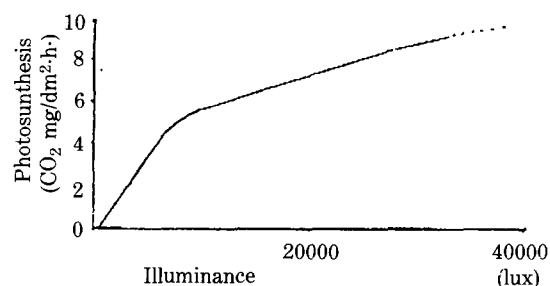

Fig. 5. The ginseng photosynthesis under the different illuminance

quent years.

III. The rational application of fertilizers

Ginseng, a perennial plant, often grows for 3-4 years at a site and absorbs lots of nutrients from the soil. No fertilizer was applied by the traditional cultivation system, which was one of the Key factors affecting the yield and quality of ginseng. To meet the needs of ginseng for various nutrients, a large number of researches has been carried out and shown that the rational application of manure of artificial compound fertilizers specially for ginseng on both new forestland and farmland is imperative in order to increase ginseng yield significantly.

Ginseng requires various nutrients. In the course of growth and development, a ginseng absorbs more nitrogen before the bloom, more phosphorus in the period of fruit formation and more potassium in the whole periods of growth. Other nutrients are also essential for ginseng growth. Our practice is: applying the manure underneath the nursery bed as a base manure during soil preparation and spraying the compound fertilizers containing different trace elements at leaf in three periods, i.e. after leaf-unfolding, in the green-fruit stage and after seed-collecting, which results in an increasing yield by 20-50% compare with that of control. The effect of increasing yield will be more better if rational applying fertilizers combinnd with suitable control of illuminance and soil moisture.

IV. The timely regulation of soil moisture

Ginseng will be damaged under the situation of drought and waterlogging. It demands a relatively

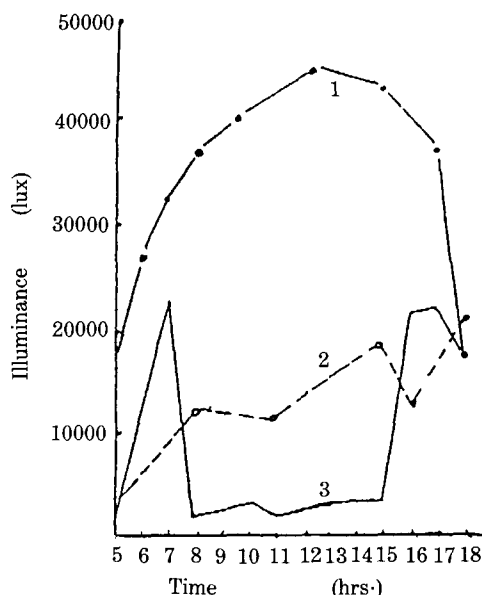

Fig. 6. The daily change of illuminance under the different shades. 1, nature light; 2, under the shade of water-proof but sunlight passing partly; 3, under the shade of water-proof and sunlight-prof

stable soil moisture. Sudden changes of soil moisture will affect the enzyme activity and the course and direction of metabolism and result in ginseng physiological function weakened, growth stunted and disease infected.

The water management is an important technical link for high ginseng yield. The meteorology in the northeast of China is a typical continental climate. The drought happened during emergence, growth of leaf and stem and bloom often causes a series of problems of withered germinating seeds, poor emergence of perennial plants and weak growth after emergence and thus affects seriously the growth of the plants. The traditional drought-relief measures in the past were these of filling up ditch in the arid seasons, loosening the walk way, digging the fish-scale pits or folding small dams to intercept the rainwater on the walk way. Watering was tabooed in the experiments that the soil moisture must be well regulated in order to meet the needs of ginseng growth. Watering ginseng timely in drought areas results in the increase of plant height and leaf area. The plants grow luxuriantly. Compared with the control, rational irrigation

makes seeds increase 27%, 3-year-old roots increase 83%, 6-year-old roots increase 20-30%.

The regulation of moisture should be varied according to soil textures. The moisture of 20-30% is suitable in the sand-loam soil containing less organic matters. It will be favourable and moistures change 30-40% in the rich sand-loam soil and 40-50% in the humus soil with high content of clayed organism. The moisture should timely be regulated by cutting the sides of bed and loosening the bed surface if the soil is over-wet and by watering in the ditch and spraying the plants, etc. if the soil shows drought.

The Prospects for the Ginseng Industry

I. The demands for ginseng and its manufactures will continuously increase

Owing to the efforts of the specialists at home and abroad the chemical compositions and pharmacological effects of ginseng have deeply revealed and universally accepted. The ginseng and its manufactures were used only in a few countries in the Southeast Asia in the past and have been utilized in more than 70 countries in Europe and America at present. Moreover, ginseng has been using not only in the medicine, but also in light and chemical industries and in the food industry. More and more people take red- or white-ginseng. The world demands for ginseng will increase gradually.

II. The ginseng industry will steadily develop in China

The three provinces in Northeast of China, as a major production area of ginseng, are located in the mountain systems of Changbaishan, Daxinganling and Xiaoxinganling and in the plain of Songliao. There are vast forest lands and plain, high mountains and dense forest, fertile soils and plentiful water sources. The frost-free period ranges from

105 to 160 days. The rainfall changes from 700 to 100 mm. The ecological conditions in the Northeast are suitable for the growth and propagation of ginseng. In this area, a series of cultivation technologies of ginseng have been developed, and a wealth of experience of cultivative ginseng has been accumulated. The "Shizhu" ginseng, "Biantiao" ginseng and ordinary ginseng produced here have a unique style with different characteristics and are greeted at home and abroad. This area might become a production base of ginseng in the world.

III. Strengthening a cooperative research to solve the problems in the production

We have done a lot for ginseng. Our efforts have been crowned with success. But there are still some weak links of the ginseng cultivation to be improved in China, such as corresponding operation machineries in the mountains, lower yield in the new cultivation areas, a radical control method to the root rot, perfect and unified processing technologies and mixed varieties used in ginseng production and so on. We expect the cooperations from the foreign specialists besides our efforts to solve them in order to make the ginseng production scale new heights in China.

References

1. Wang Rongsheng *et al.*: Cultivative Techniques of Growing Ginseng in Jinlin Province, 1984.
2. Proceedings of Increasing Economic Benefit of Ginseng and Its Manufactures Conference, 1982.
3. Wang Rongsheng *et al.*: The New Techniques of Ginseng Cultivation, 1987.
4. Chen Fuzeng: Ginseng History of Fusong County. Jinlin People's Publishing House, 1989.
5. Jilin People's Publishing House: The Origin and Development of Jinlin Ginseng in China, 1988.